



47D01U-843

WARNING

Do not use on circuits exceeding specified voltage. Higher voltage will damage control and could cause shock or fire hazard. Route and secure wiring away from flame. Protect the control from direct contact with water. If the control has been in direct contact with water, replace the control.

CAUTION

To prevent electrical shock and/or equipment damage, disconnect electrical power to system, at main fuse or circuit breaker box, until installation is complete.

Failure to read and follow all instructions carefully before installing or operating this control could cause personal injury and/or property damage.

INDEX

Installation	2-3
Wiring	2
Setup	4-7
Quick Setup	4-5
Operation	6-7
Troubleshooting	8

The 47D01U-843 a universal replacement defrost control for single stage heat pump systems. The control is configurable for both demand, and time/temp defrost routines.

It is equipped with:

- 8 X 8 LED matrix display for set-up, operation and system troubleshooting
- Quick set-up menu by compressor brand.
- Outdoor thermostat functions to lock out compressor and / or aux. heat (optional)
- Short cycle and random start delays (optional)
- 24V brownout protection (optional)

PRECAUTIONS

- Installation should be done by a qualified heating and air conditioning contractor or licensed electrician.
- Do not exceed the specification ratings.
- All wiring must conform to local and national electrical codes and ordinances.
- This control is a precision instrument and should be handled carefully.
- Rough handling or distorting components could cause the control to malfunction.
- Follow installation/replacement instructions to ensure proper operation.
- The 47D01U-843 has no user serviceable parts. Replace as a unit.

SPECIFICATIONS

Electrical Rating:	
Input Voltage	24 VAC (Nominal) 50/60 Hz
Max. Input Current:	
Contactors Coil	24 VAC (Nominal) 50/60 Hz
Aux Heat	24 VAC (Nominal) 50/60 Hz
Reversing Valve	24 VAC (Nominal) 50/60 Hz
Outdoor Fan	1/2 HP @ 240V
Operating Temperature Range	-40° to +150° F (-40° to +65° C)
Humidity Range	0 to 95% RH, Non-Condensing
Mounting	Multi-Position Surface Mount
Timing Specs	+/- 5% nominal over full voltage / temperature range.
	Timings 20% longer at 50Hz

INSTALLATION

47D01U-843 Contents	Description
47D01U-843 Control	Universal defrost control with plastic mounting tray
Thermostat Harness	Harness used to connect thermostat wire to defrost control
Harness #2	Harness used to connect reversing valve, contactor, low and high pressure switches
Sensor	Used to measure coil temperature and air temperature
Bag of Accessories	2- Mounting screws, wire ties, wire nuts and labels.



Thermostat Harness



Harness #2



Coil Temperature Sensor



Air Temperature Sensor

WIRING

Refer to equipment manufacturer's instructions for specific system wiring information. Wiring tables shown are for typical systems and describe the standard functions.

Diagram 1: OEM Wiring Diagram

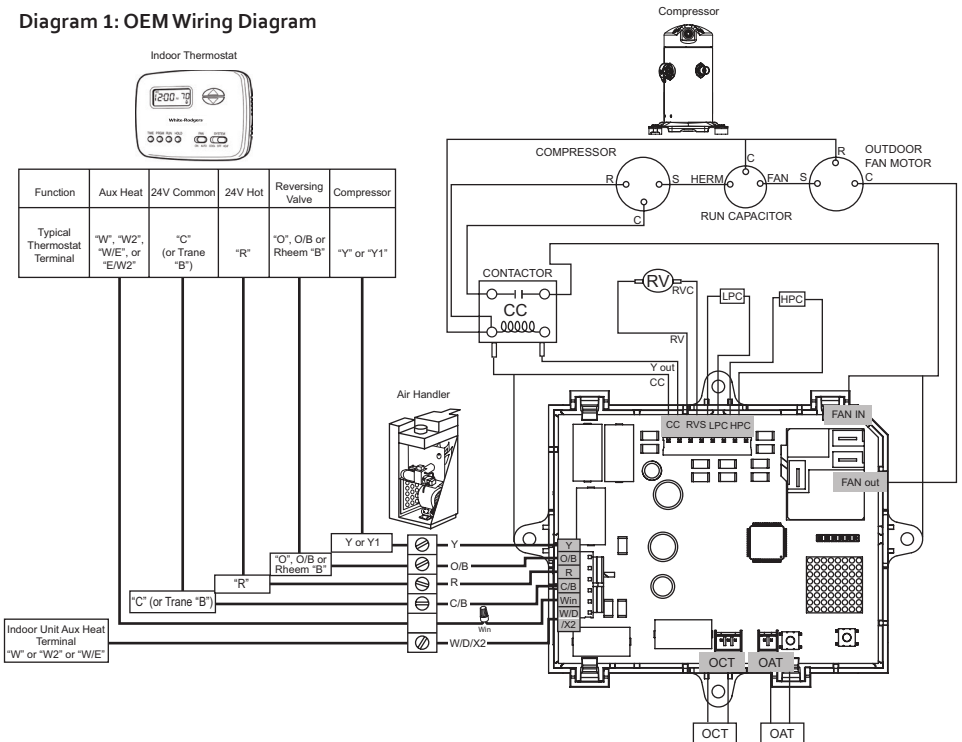

WIRING TABLE

47D01U-843 Lead Label	47D01U-843 Module Label	Description	Control Input/ Output	Goodman	Carrier (T2 and T1 Terminal)	Carrier (T1 Terminal only)	Lennox	Trane	Rheem	York	Nordyne	
Thermostat / Air Handler Connections	Y-in	Y	Connection from Indoor Unit or Thermostat "Y" - first stage heat / cool call	IN	Y ¹	Y	Y	Y1	Y	Y	Y	Y
	O/B	O/B	Connection from Indoor Unit or Thermostat - reversing valve "O" (or Rheem "B")	IN	O	O	O	O	O	B	O	O
	R	R	Connection from Indoor Unit, 24 VAC power "R"	IN	R	R	R	R	R	R	R	R
	C/B	C/B	Connection from Indoor Unit, 24 VAC Common "C" (or Trane "B")	IN	C	C	C	C	B	C	C	C
	W-in	Win	Connection directly from Thermostat Auxiliary Heat Terminal (W or W2 or W/E or E/W2) for integrated outdoor thermostat function	IN							W	E/W2 in
	W/D/X2	W/D/X2	Connection to indoor unit Auxiliary Heat terminal - Energizes Auxiliary Heat during defrost and integrated outdoor thermostat operation "W1", "W2", "X2"	OUT	W2 or W	W2	W2	W1	X2	D	W1/66	W2
Internal Heat Pump Connections	CC	CC	Attach to Compressor Contactor Coil	OUT	CNT	T2	T1	Y1-out	Yo ¹	Yout	M	T2
	Y-out	CC	Attach to Compressor Contactor Coil	OUT	C	C	C		B	CC	C	C/M
	RV	RVS	Attach to Compressor Reversing Valve Coil	OUT	C-RV	C	C	O out	B	C	RV	C/REV
	RVC	RVS	Attach to Compressor Reversing Valve Coil (Common)	OUT	O-RV	O	O		O	RV	RV	(O)/Valve
	LPC	LPC	Connections from system low pressure sensor	IN	R-PS1	Remove Y(out), T1. Connect the LPS leads to the low pressure switch	Remove Y(out). Connect the LPS leads to the low pressure switch	LO-PS	Connect the LPC leads to the LPCO low pressure switch	LPC	Remove PS/PS. Connect the LPS leads to the low pressure switch	Remove PRESS/ SW. Connect the LPS leads to the low pressure switch
	LPC	LPC		IN	PS2/R- PS1 ¹							
	HPC	HPC	Connection from system high pressure sensor	IN	See Note 1	Connect the HPS leads to the High pressure sensor		HI-PS	Connect the HPS Leads to the HPCO high pressure sensor	HPC	Connect the HPS leads to the high pressure sensor	Connect the HPS leads to the High Pressure Sensor
	HPC	HPC	Connection from system High Pressure Sensor	IN								
	Fan In	FAN IN	Connection from Outdoor Fan (IN)	IN	DF1	OF1	OF1	FAN	M1	Fan	COND	DF1/Fan
	Fan Out	FAN OUT	Connection to Outdoor Fan (Out)	OUT	DF2	OF2	OF2		M1	Fan	FAN	DF2/Cond
OAT	OAT	Connect Outdoor Air Temperature Sensor	IN		Install provided air temperature sensor and place outside unit.					Discard (AMB/ AMBG) and Install provided air temperature sensor and place outside unit.	Discard (AMBG) and Install provided air temperature sensor and place outside unit.	
OAT	OAT		IN									
OCT	OCT	Connect Outdoor Coil Temperature Sensor	IN		Discard (DFT / R-DFT) and Install provided Coil Temp Sensor in place of Defrost Thermostat (DFT)			Discard (DF) and Install provided Coil Temp Sensor in place of Defrost Thermostat	Discard (D) and Install provided Coil Temp Sensor in place of Defrost Thermostat	Install provided Coil Temp Sensor in place of Defrost Thermostat	Discard (COILG/ COIL) and Install provided Coil Temp Sensor in place of Defrost Thermostat	Discard (DFT / R) and Install provided Coil Temp Sensor in place of Defrost Thermostat (DFT)
OCT	OCT		IN		Discard (DFT / R-DFT) and Install provided Coil Temp Sensor in place of Defrost Thermostat (DFT)							

¹ For existing systems without dedicated high and low pressure control inputs, it is recommended that pressure switches be wired directly into the Udefrost control (LPC & HPC) allowing advanced diagnostics and additional equipment protection. Reference the equipment wiring diagram. Additional wire required depending on application.

Note: Check existing system wiring diagram to verify connections.

Note: Table above represents typical connections only. Always check equipment wiring diagram first.

Note: Existing OAT and OCT sensor must be replaced.

Mounting (Reference Wiring Table)

- 1.) Disconnect power to unit
- 2.) Label wires (Reference OEM wiring diagram below)
- 3.) Take a picture of the current installation
- 4.) Remove existing control
- 5.) Remove wires from control
- 6.) Position the control and secure with provided mounting screws in desired location
- 7.) Connect labeled thermostat wires to thermostat harness and connect to the control
- 8.) Connect remaining labeled wires to harness #2 and connect to the control
- 9.) Connect outdoor coil temperature sensor
- 10.) Connect outdoor air temperature sensor
- 11.) Connect high pressure switch
- 12.) Connect low pressure switch

High/Low pressure switches are default enabled. Refer to table 2.

SETUP

The 47D01U-842 control utilizes an 8x8 matrix display and two push buttons (OPTION) and (SELECT) to provide the user an easy and efficient way to setup the control.

OEM Quick Set-Up

- 1.) Turn the thermostat "Off" or disconnect the "Y" lead at the control to cancel any thermostat call for heat or cool.
- 2.) Turn on power, LED will display (all segments) followed by standby (☺)
- 3.) Press the OPTION button for 1 second, control will display (do). Press SELECT until the characters (Hi / ㄣ / !H / ㄨ) are in an easy to read position (HI).
- 4.) Locate the Display number for the OEM equipment brand in the table below.
 - Press OPTION 3 more times or until (oE) is displayed. Press SELECT until the control Display is set to the OEM number.
 - Press OPTION again to confirm the setting - the control will display (Oe).
 - Press OPTION (Repeatedly) until standby (☺) appears or wait 30 seconds for the control to return to standby (☺)

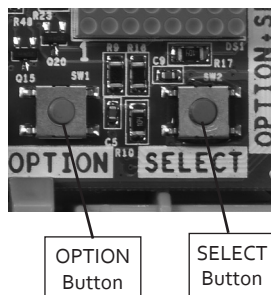

This configures the control to the standard OEM settings*.

***Note:** Individual set-up items can be customized using the full set-up table on the following page.

- 5.) Run the Forced Defrost - Quick Test below.

Forced Defrost - Quick Test Mode

This test provides a fast defrost cycle (about 30 seconds) to verify everything is connected correctly.

- 1.) Set the thermostat to call for Heat (Heat Pump) and verify the "Y" connection is attached to the control.
 - The control will display "H" (Heating). Note: If the control blinks "H" the compressor time delay is active. To bypass the delay Press Option and Select for 1 second (control will briefly display (T)) or wait for the delay to time out.
- 2.) With the heat pump running (control displays "H") Press Option and Select for 1 second. Control will display "T" (Test Mode) followed by "D" (Defrost).
 - The reversing valve will change direction
 - Aux Heat will energize
 - Outdoor fan will turn off
 - The Defrost test will end, control will display (H) (Heating).

The control is now ready for normal operation.

Note: If the control blinks "H" the compressor time delay is active. Press OPTION and SELECT for 1 second (control will briefly display (T)) to bypass the delay or wait for the delay to time out.

Note: If the control blinks "C" the compressor time delay is active. Press OPTION and SELECT for 1 second (control will briefly display (T)) to bypass the delay or wait for the delay to time out.

High/Low pressure switches are default enabled. Refer to table 2.

Table 1: OEM Quick Setup Options

Display	OEM	Defrost Type	Defrost Cycle Time	Short Cycle Time	RV Power	RV Shift Delay	Max Defrost Time	Defrost Enable Coil Temp	Defrost Terminate Coil Temp
	Carrier	T/T	90 min	5 min	O	0 sec	10 min	30°	65°
	Goodman	T/T	30 min	5 min	O	30 sec	10 min	35°	70°
	Lennox	Demand	n/a	5 min	O	30 sec	14 min	35°	50°
	Trane	Demand	n/a	0 min	O	12 sec	14 min	36°	50°
	Rheem	Demand	n/a	5 min	B	30 sec	14 min	35°	70°
	York	Demand	n/a	5 min	O	30 sec	8 min	31°	80°
	Nordyne	Demand	n/a	3 min	O	30 sec	14 min	35°	70°
	Factory Default	Demand	n/a	5 min	O	30 sec	14 min	35°	70°

For additional setup options refer to Table 2

Table 2: Setup Table Options

To customize Set-Up options press the OPTION button to advance through the table.

To change a setting press SELECT. To confirm the choice press Option again.

When finished with Set-Up options press Option until (☺) appears or wait 30 seconds for the control to time out.

Set-Up Feature	Pressing Option Button Displays	Pressing Select Button (Choices)	Set-Up Details																		
Display Orientation			Rotates the display for easy viewing																		
Error		(Reference Troubleshooting section)	Displays current system errors. See Table 3, Troubleshooting.																		
Fault Recall		(Reference Troubleshooting section)	Displays stored system errors. See Table 3, Troubleshooting.																		
Quick Setup by OEM		<table border="1"> <tr> <td>1</td><td>2</td><td>3</td><td>4</td></tr> <tr> <td>5</td><td>6</td><td>7</td><td>8*</td></tr> </table>	1	2	3	4	5	6	7	8*	<table border="1"> <tr> <td colspan="2">Selects</td> </tr> <tr> <td>Carrier(1)</td> <td>Rheem(5)</td> </tr> <tr> <td>Goodman(2)</td> <td>York(6)</td> </tr> <tr> <td>Lennox(3)</td> <td>Nordyne(7)</td> </tr> <tr> <td>Trane(4)</td> <td>Default (8)</td> </tr> </table>	Selects		Carrier(1)	Rheem(5)	Goodman(2)	York(6)	Lennox(3)	Nordyne(7)	Trane(4)	Default (8)
1	2	3	4																		
5	6	7	8*																		
Selects																					
Carrier(1)	Rheem(5)																				
Goodman(2)	York(6)																				
Lennox(3)	Nordyne(7)																				
Trane(4)	Default (8)																				
Defrost type		*	Selects Demand defrost or Timed Temperature defrost.																		
Enable temperature		<table border="1"> <tr> <td>30</td><td>31</td><td>32</td></tr> <tr> <td>33</td><td>34</td><td>35*</td><td>36</td></tr> </table>	30	31	32	33	34	35*	36	Selects coil temperature (degrees F) allowing timed / temperature or demand defrost to accumulate run time. Above this temperature a defrost cycle will not occur.											
30	31	32																			
33	34	35*	36																		
Termination temperature		<table border="1"> <tr> <td>50</td><td>65</td></tr> <tr> <td>* 70</td><td>75</td><td>80</td></tr> <tr> <td>90</td><td>100</td></tr> </table>	50	65	* 70	75	80	90	100	Selects desired coil temperature to terminate defrost cycle (Degrees F)											
50	65																				
* 70	75	80																			
90	100																				
Defrost cycle time (timed / temp defrost only)		*	Selects accumulated compressor run time (minutes) before entering defrost mode. (Appears for Timed Temperature defrost systems only).																		
Short cycle time			Selects minimum time delay (minutes) between cycles. More info, page (XX).																		
Reversing valve power		*	"O" selection energizes Reversing Valve in Cool, "B" energizes Reversing Valve in Heat (B).																		
Reversing valve shift delay time			Selection limits excessive noise in and out of a defrost cycle (in seconds). More info, page (7).																		

* Denotes Default Setting

Note: Options time out after 30 seconds

Table 2: Set-up Table Options

Set-Up Feature	Pressing Option Button Displays	Pressing Select Button (Choices)	Set-Up Details
Maximum defrost time	dt	0 10 14*	Selection limits maximum Defrost Time (minutes)
Auxiliary heat lockout	HL	0 10 15 20 25 30 35 40 of*	Settings allow the control to act as an outdoor thermostat to prevent auxiliary heat from coming on until the outdoor temperature drops to the selected temperature (Degrees F). More info, page (7).
Low temp compressor cutout	Lt	-10 0 10 15 20 25 30 35 of*	Settings allow the control to act as an outdoor thermostat to turn off the heat pump and use only Auxiliary heat when it's too cold for the pump to operate efficiently (Degrees F). More info, page (7).
Brownout Random Time start delay	rt	* on of	"On" selects a 5 to 90 second Random Time start delay after a brownout. More info, page (7).
Low Pressure switch	LP	* on of	Accommodates systems with or without a Low Pressure Switch - if the system does not have a low pressure switch set to "of"
High Pressure switch	HP	* on of	Accommodates systems with or without a High Pressure Switch - if the system does not have a high pressure switch set to "of"
24V Brownout Protection	Bo	* on of	"On" turns off the compressor and fan if low voltage drops below 15.5 VAC. More info, page (7).

* Denotes Default Setting
Note: Options time out after 30 seconds

OPERATION

Demand Defrost Mode

Configured for demand defrost the controller monitors the mode of operation through the "B/O" terminal, outdoor temperature, outdoor coil temperature and compressor run time to determine when a defrost cycle is required.

- Defrost is initiated by calculating the difference between the outdoor temperature and coil temperature.
- At initial power up, a sacrificial defrost cycle initiates to make sure residual frost/ice has not accumulated on the coil before the control can calibrate itself.

Timed/Temperature Defrost Mode

Configured for Timed/Temperature defrost the control uses the outdoor temperature sensor, the defrost enable temperature and the defrost cycle time to initiate a defrost cycle.

- Compressor run time is accumulated when the coil temperature is below the defrost enable temperature (ET).
- If the compressor run time accumulated reaches the defrost cycle time, the control will enter defrost mode (dc).

Defrost Sequence for both Demand and Time/Temperature Modes

- Energize the auxiliary heat signal "W/D/X2" (out)
- Switch the RV to cool mode and initiate Defrost Compressor Switching Delay
- De-energize the compressor after "Defrost Compressor Switching Delay" time and initiate RV Shift Delay if RV Shift Delay selected is not zero. The system will not de-energize the compressor if the RV Shift Delay selected is zero.
- De-energize the FAN.
- The system will wait for the RV Shift Delay to expire if the RV Shift Delay selected is not zero.
- Energize the compressor to start the Defrost operation, ignoring the Compressor Short Cycle Delay
- Defrost is terminated when the coil temperature exceeds the selected termination temperature, or by maximum defrost time.

Short Cycle Time

At power-up as well as any time the compressor is de-energized, the control will activate a short cycle delay. During this delay the compressor will not be energized, even if a call for compressor operation is present. This is to prevent compressor damage due to rapid on and off cycling. Normal operation will resume when the delay expires.

Default Short cycle setting (SS) is at least 5 minutes. Selecting a shorter time could potentially shorten the life of the equipment.

Reversing Valve Shift Delay

This feature is used to limit potential noise issues on some compressors whenever the unit switches the reversing valve going in/out of the defrost cycle.

The reversing valve Shift Delay (Sd) is defaulted at 30 seconds.

Integrated Outdoor Thermostat Functionality (Optional). Aux Heat Lockout/Low Temp. Compressor Cutout.

Referencing Wiring Table (page 3)

Allows selection of an auxiliary heat cutout temperature (Aux Heat Lockout temperature). A user selectable low temperature cutout setting for the compressor can also be selected to prevent the compressor from operating below desired temperatures.

- Connection must be made from the indoor thermostat AUX to the Win located on the 47D01U-843 board.
- Select an Aux lockout temperature from the menu (hL).
- Select compressor lockout temperature from the menu (Lt).

Brownout Random Time Start Delay

At power-up and when the 47D101U-843 recovers from a brownout, a random time start delay of 5-90 seconds will be activated. This delay is in addition to the short cycle delay. During this delay the compressor will not be energized, even if a call for compressor operation is present. The random start delay can help reduce spikes in power consumption when multiple loads are re-energized after a blackout or brownout. The random time start delay is only active at initial power-up when recovering from a brownout. Normal compressor cycling will not activate the random start delay.

Random Time Start Delay (Rt) can be disabled by setting to the OFF position.

Brownout Protection

Brownout protection will de-energize the compressor and fan if the control voltage drops below 15.5V for more than 4 seconds during a call for compressor operation. Compressor operation will not resume until the control voltage returns to a minimum of 17.5V.

Brownout protection (Bo) can be disabled by setting to the off position (of).

TROUBLESHOOTING















Active Error

Active errors are fault conditions present in the system. The highest priority error will show toggling between the operating condition followed by a 1 second pause. Any remaining active errors are displayed in the "Er" Error Menu. Once the condition is corrected, the errors will be removed from active status.

Fault Recall

Stored errors are fault conditions that can be recalled in the "Fr" menu. The last four faults will be stored with a maximum of two identical faults. Holding the OPTION+SELECT switch for greater than 7 seconds and less than 10 seconds will clear all fault(s). The display will flash "_ " and "_ " three times to indicate the fault(s) are successfully removed.

Table 3: Troubleshooting

8x8 Display	Error/ Condition	Comments/Troubleshooting
	Power up	Normal Operation. During power up all LED's on the 8x8 matrix display will light up
	Standby	Normal operation with power and no active call
	Running in cooling mode	Steady on represents an active call for cooling. Blinking represents short cycle or other time delay active with a compressor demand.
	Running in heating mode	Steady on represents an active call for heating. Blinking represents short cycle or other time delay active with a compressor demand.
	Running in defrost mode	Represents the control in defrost mode.
	Field test mode	This code will be displayed till the OPTION+SELECT buttons are pressed. Applicable to short cycle bypass as well as forced defrost field test mode.
	LPC trip	Low pressure switch must be connected to the control and option selected from menu. If low pressure switch opens during an active call the system will shut down. Normal operation will resume after switch is closed
	LPC lockout	If the low pressure switch opens 3 times the control will lockout.
	HPC trip	High pressure switch must be connected to the control and option selected from menu. The pressure switch is normally closed. On open condition will trigger this error. Normal operation will resume after switch is closed
	HPC lockout	If the high pressure switch opens 3 times the control will lockout.
	Air sensor fault	Outdoor Air Temperature Sensor (OAT) is at fault. Possible bad connection. Sensor is rated 10K ±1% @25° C.
	Coil sensor fault	Outdoor Coil Temperature Sensor (OCT) is at fault. Possible bad connection. Sensor is rated 10K ±1% @25° C.
	Two consecutive defrosts terminated on maximum defrost time	
	Low control voltage (24V brownout)	Possible 24V brownout condition
	Control failure	Check for miswire of 24 VAC on Yout/cc. If error continues, replace control.