

Application

Designed for installation on water lines in fire protection systems to protect against both backsiphonage and back-pressure of contaminated water into the potable water supply. The Model 375DA shall provide protection where a potential health hazard exists. Incorporates metered by-pass to detect leaks and unauthorized water use.

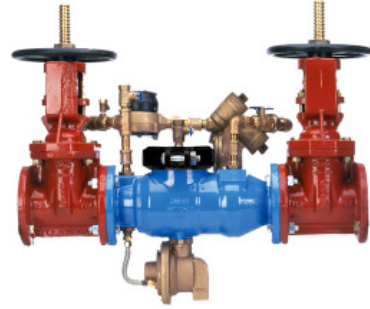

Standards Compliance

(Unless otherwise noted, applies to sizes 2 1/2" thru 10")

- ASSE® Listed 1047
- UL® Classified
- AWWA Compliant C550
- CSA® Certified B64.4 (4" & 6")
- C-UL® Classified
- FM® Approved
- NYC MEA 218-01-M VOL 3
- Approved by the Foundation for Cross Connection Control and Hydraulic Research at the University of Southern California
- Meets the requirements of NSF/ANSI 61*

* (0.25% MAX. WEIGHTED AVERAGE LEAD CONTENT)

By-Pass Backflow Assembly 3/4" Model 975XLD

Materials

Main valve body	Ductile Iron ASTM A 536
Access covers	Ductile Iron ASTM A 536
Coatings	NSF Approved fusion epoxy finish
Internals	Stainless steel, 300 Series NORYL™
Fasteners	Stainless Steel, 300 Series
Elastomers	EPDM (FDA approved) Buna Nitrile (FDA approved)
Polymers	NORYL™
Springs	Stainless steel, 300 series
Sensing line	Stainless steel, braided hose

Options

(Suffixes can be combined)

- with OS & Y gate valves (standard)
- L - less shut-off valves (flanged body connections)
- LM - less water meter
- with remote reading meter
- with gpm meter (standard)
- CFM - with cu ft/min meter
- G - with groove end gate valves
- FG - with flanged inlet gate connection and grooved outlet gate connection
- MS - with Integral Relief Valve Monitor Switch
- PI - with Post Indicator Gate Valve
- GF - with flanged inlet connection and grooved outlet connection
- BG - with grooved end butterfly valves with integral monitor switches (2 1/2" - 10")
- 509 - with AWWA C509 gate valves

Accessories

- Air gap (Model AG)
- Repair kit (rubber only)
- Thermal expansion tank (Model XT)
- OS & Y Gate valve tamper switch (OSY-40)
- QT-SET Quick Test Fitting Set

Attention:
Model 375DA (flange body) and
Model 375ADA
(grooved body) have different lay lengths.

Relief Valve discharge
port:
2 1/2" - 6" - 2.75 sq. in.
8" - 10" - 3.69 sq. in.

Features

Sizes:	2 1/2", 3", 4", 6", 8", 10"
Maximum working water pressure	175 PSI
Maximum working water temperature	140°F
Hydrostatic test pressure	350 PSI
End connections (Grooved for steel pipe)	AWWA C606
(Flanged)	ANSI B16.1
	Class 125

Model 375DAG SHOWN BELOW

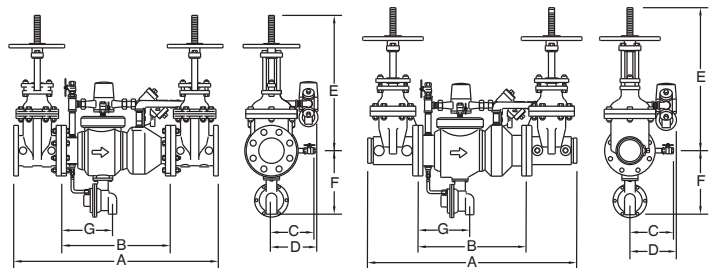

Dimensions & Weights (do not include pkg.)

MODEL 375DA SIZE	DIMENSION (approximate)															WEIGHT													
	A		A WITH BUTTERFLY VALVES		B LESS GATE VALVES		C		D		E OS&Y OPEN		E OS&Y CLOSED		E WITH BUTTERFLY VALVES		F		G		LESS SHUT- OFF VALVES	OS&Y GATE VALVES FLANGED	OS&Y GATE VALVES GROOVED	BUTTERFLY VALVES GROOVED					
	in.	mm	in.	mm	in.	mm	in.	mm	in.	mm	in.	mm	in.	mm	in.	mm	in.	mm	in.	mm	in.	mm	lbs.	kg	lbs.	kg	lbs.	kg	lbs.
2 1/2	65	31	787	28	711	15 7/8	403	7 1/4	184	9	229	17 3/4	451	15 3/8	391	8 1/4	210	9 1/2	241	8 3/8	213	75	34	185	84	167	76	147	67
3	80	32	813	28 1/2	724	15 7/8	403	7 1/4	184	9	229	20 1/4	514	17	432	8 1/2	216	9 1/2	241	8 3/8	213	78	35	208	94	160	73	130	59
4	100	37 5/8	956	32 8/9	835	19 1/2	495	8	203	9	229	22 1/2	572	18 1/4	464	9	229	11	279	9 1/4	235	116	53	306	139	292	132	200	91
6	150	44 3/4	1137	37 5/8	956	23 1/2	597	10	254	10 1/2	267	30 1/2	775	24 1/4	616	10 1/4	260	12 3/8	314	9 1/4	235	194	88	494	224	468	212	312	142
8	200	60 3/4	1543	53 7/8	1369	37 3/4	959	11	279	15 1/2	394	37	940	28 1/2	724	12	305	15 3/8	391	16 3/4	426	382	173	858	389	810	367	556	252
10	250	63 3/4	1619	57 7/8	1470	37 3/4	959	11	279	15 1/2	394	45 5/8	1159	34 3/4	883	13	330	15 3/8	391	16 3/4	426	412	187	1230	558	1164	528	800	363

MODEL 375DA 2 1/2", 3" & 4" (STANDARD & METRIC)

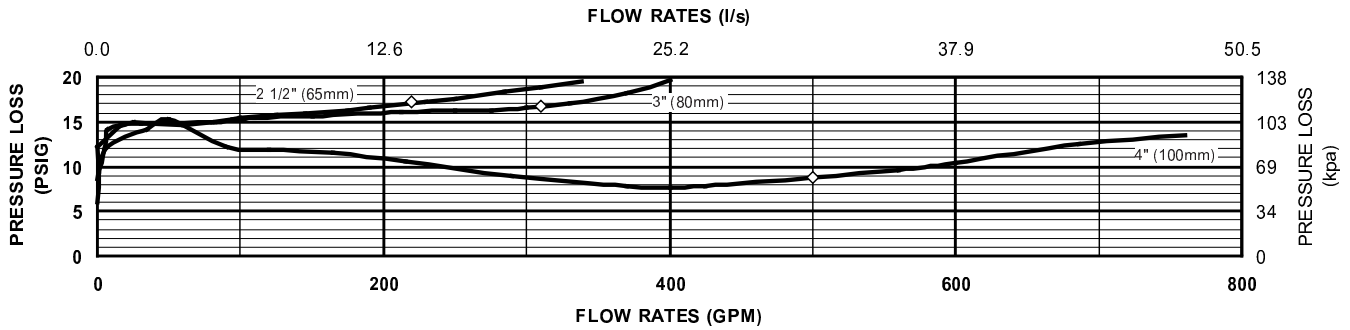

MODEL 375DA 6", 8" & 10" (STANDARD & METRIC)

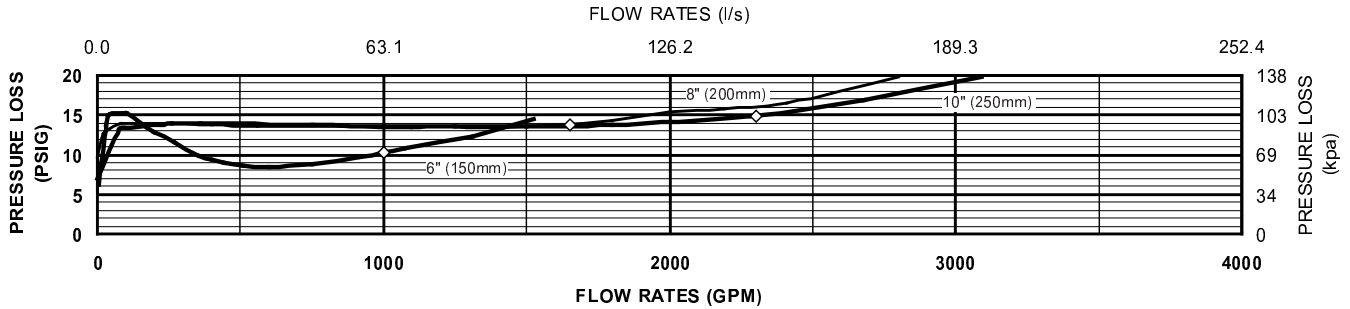

Typical Installation

Local codes shall govern installation requirements. To be installed in accordance with the manufacturer’s instructions and the latest edition of the Uniform Plumbing Code. Unless otherwise specified, the assembly shall be mounted at a minimum of 12" (305mm) and a maximum of 30" (762mm) above adequate drains with sufficient side clearance for testing and maintenance. The installation shall be made so that no part of the unit can be submerged.

Capacity thru Schedule 40 Pipe (GPM)				
Pipe size	5 ft/sec	7.5 ft/sec	10 ft/sec	15 ft/sec
2 1/2"	75	112	149	224
3"	115	173	230	346
4"	198	298	397	595
6"	450	675	900	1351
8"	780	1169	1559	2339
10"	1229	1843	2458	3687
12"	1763	2644	3525	5288

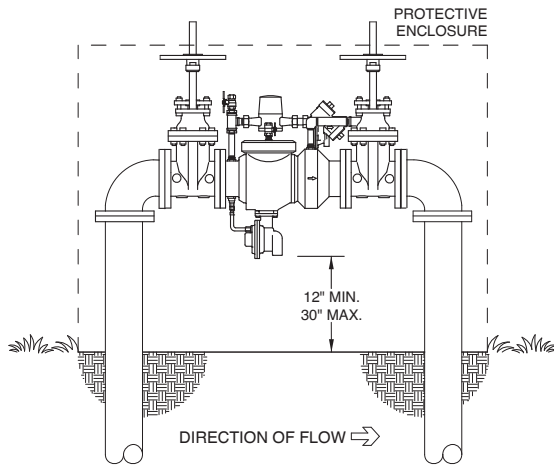

OUTDOOR INSTALLATION

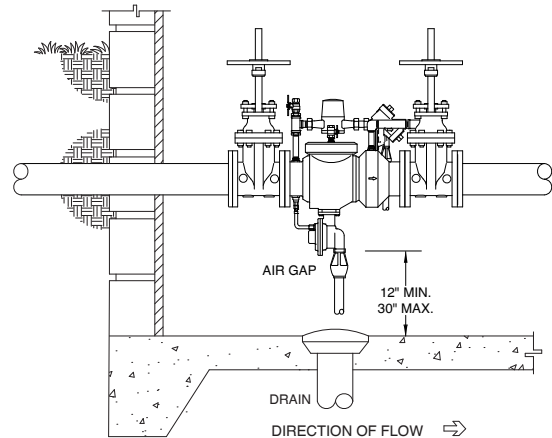

INDOOR INSTALLATION

Specifications

The Reduced Pressure Detector Backflow Prevention Assembly shall be certified to NSF/ANSI 61, ASSE® Listed 1047, and supplied with full port OS & Y gate valves. The main body and access cover shall be epoxy coated ductile iron (ASTM A 536), the seat ring and check valve shall be NORYL™, the stem shall be stainless steel (ASTM A 276) and the seat disc elastomers shall be EPDM. The checks and the relief valve shall be accessible for maintenance without removing the device from the line. The Reduced Pressure Detector Backflow Prevention Assembly shall be a ZURN WILKINS Model 375DA.