

THIS SPACE FOR DESIGNER/ENGINEER APPROVAL

Job/Customer _____	Date _____	Contractor _____
Model Specified _____	Qty _____	Approved By _____
Designer/Engineer _____	Date _____	Contractor's PO# _____
Submitted By _____	Date _____	Other _____

**1062 Series
Forged Brass Swing Check Valve
Hard Seat
CxC
200 WOG/125 WSP
ISO 9001**

Lead free products are certified to NSF/ANSI 61-G

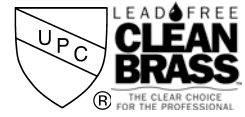

ITEM #	SIZE	CTN	CASE	H	L
10622W	1/2"	10	120	1 5/16	2 7/16
10623W	3/4"	10	80	1 1/2	3 3/16
10624W	1"	10	60	1 9/16	3 9/16
10625W	1 1/4"	5	40	1 7/8	4 5/16
10626W	1 1/2"	5	30	2 1/4	4 3/4
10627W	2"	5	10	2 11/16	5 7/16

NO.	DESCRIPTION	MATERIAL
1	CAP	BRASS
2	PACKING	LOCTITE
3	DISC	BRASS
4	BODY	BRASS
5	BOLT	BRASS
6	PIN	BRASS

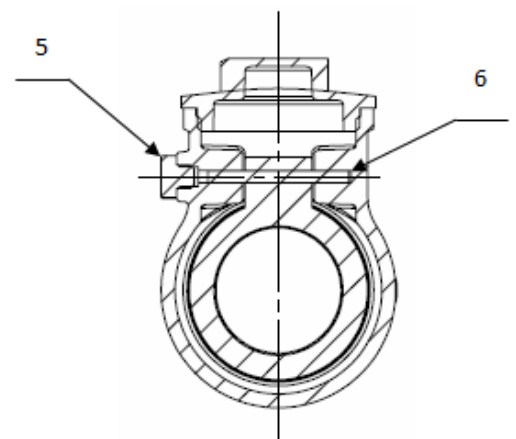
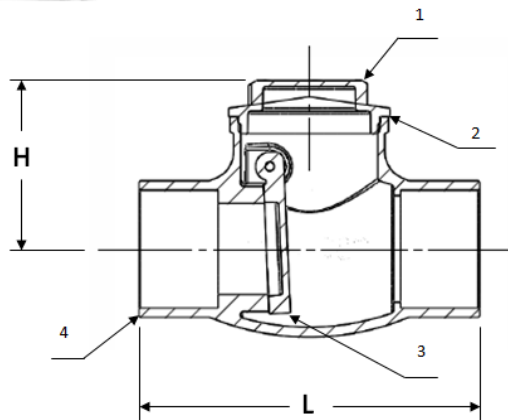

Quality and Commitment Since 1954

www.webstonevalves.com · P: (800) 225-9529 · F: (800) 336-5133

Webstone product specifications in U.S. customary units are approximate and are provided for reference only. Webstone reserves the right to change or modify product design, construction, specifications or materials without prior notice and without incurring any obligation to make such changes and modifications on Webstone products previously or subsequently sold.

1062Spec_061315