



Series 1

*Models 750 - 1100
Commercial Condensing
Gas-fired water boilers*

User's Information Manual



▲WARNING

If the information in this manual is not followed exactly, a fire or explosion may result, causing property damage, personal injury or loss of life.

Do not store or use gasoline or other flammable vapors and liquids in the vicinity of this or any other appliance.

— WHAT TO DO IF YOU SMELL GAS —

- Do not try to light any appliance.
- Do not touch any electrical switch; do not use any telephone in your building.
- Immediately call your gas supplier from a neighbor's telephone. Follow the gas supplier's instructions.
- If you cannot reach your gas supplier, call the fire department.
- Installation & service must be performed by a qualified installer, service technician or the gas supplier.



How to use this manual . . .

To . . .	Read/use . . .	See pages . . .
Learn precautions	Warnings and definitions	1 – 3
Start or shutdown the boiler	Use the OPERATING INSTRUCTIONS	4
Identify and locate boiler components & the control display	These illustrations and call outs will show you the location of main components and use of the control display.	5 – 8
Prevent air contamination	Read the list of air contaminants you must avoid. If found, either remove the products permanently, or have your installer relocate boiler vent and air terminations to an uncontaminated area.	9
Maintain the boiler	Maintain the boiler using the schedule in this manual. Schedule an annual start-up by a qualified service technician before every heating season.	9 – 15

Hazard definitions

The following defined terms are used throughout this manual to bring attention to the presence of hazards of various risk levels or to important information concerning the life of the product.

▲ DANGER Indicates presence of hazards that will cause severe personal injury, death or substantial property damage.

▲ CAUTION Indicates presence of hazards that will or can cause minor personal injury or property damage.

▲ WARNING Indicates presence of hazards that can cause severe personal injury, death or substantial property damage.

NOTICE Indicates special instructions on installation, operation or maintenance that are important but not related to personal injury or property damage.

Boiler service and maintenance

▲ WARNING The Boiler manual is for use only by a qualified heating installer/service technician. Refer only to this User's Information Manual for your reference. Improper installation, adjustment, alteration, service or maintenance can cause property damage, personal injury (exposure to hazardous materials) or loss of life. Installation and service must be performed by a qualified installer, service agency or the gas supplier (who must read and follow the supplied instructions before installing, servicing, or removing this boiler. This boiler contains materials that have been identified as carcinogenic, or possibly carcinogenic, to humans).

NOTICE When calling or writing about the boiler— Please have the boiler model number from the boiler rating label and the CP number from the label located on the back of the boiler.



STOP! READ THIS BEFORE PROCEEDING . . .

⚠ WARNING Failure to adhere to the guidelines on this page can result in severe personal injury, death or substantial property damage.

Boiler service and maintenance —

- ❑ To avoid electric shock, disconnect all electrical supplies to the boiler before performing maintenance if wiring will be exposed.
- ❑ To avoid severe burns, allow boiler to cool before performing maintenance.
- ❑ You must maintain the boiler as outlined in this manual and **have the boiler started up and serviced at least annually** by a qualified service technician to ensure boiler/system reliability.

Boiler operation —

- ❑ Do not block flow of combustion or ventilation air to boiler. This boiler is equipped with a control which will automatically shut down the boiler should air or vent be blocked. If vent or air blockage is easily accessible and removable, remove it. If the boiler display indicates a manual reset lockout, follow the procedure on Figure 8, page 8 to reset the boiler. (If blockage is not obvious or cannot be removed, have the boiler and system checked by a qualified service technician.)
- ❑ Do not allow contaminated air to enter the boiler room (or air inlet pipe if direct vented). See page 9 for details. Should overheating occur or gas supply fail to shut off, do not turn off or disconnect electrical supply to boiler. Instead, shut off the gas supply at a location external to the appliance.
- ❑ Do not use this boiler if any part has been under water. Immediately call a qualified service technician to inspect the boiler and to replace any part of the control system and any gas control, which has been under water.

Boiler water —

- ❑ Have boiler water chemistry checked at least annually by a qualified service technician.
- ❑ DO NOT use petroleum-based cleaning or sealing compounds in boiler system. Gaskets and seals in the system may be damaged. This can result in substantial property damage.
- ❑ DO NOT use “homemade cures” or “boiler patent medicines”. Serious damage to boiler, personnel and/or property may result.
- ❑ Continual fresh makeup water will reduce boiler life. Mineral build-up in boiler heat exchanger reduces heat transfer, overheats the metal, and causes heat exchanger failure. Addition of oxygen can cause internal corrosion in system components. Leaks in boiler or piping must be repaired at once to prevent makeup water.
- ❑ Do not add cold water to hot boiler. Thermal shock can cause boiler heat exchanger to crack.

⚠ CAUTION Frozen Water Damage Hazard

Residences or buildings that are unattended in severely cold weather, boiler system components failures, power outages, or other electrical system failures could result in frozen plumbing and water damage in a matter of hours. For your protection, take preventative actions such as having a security system installed that operates during power outages, senses low temperature, and initiates an effective action. Consult with your boiler contractor or a home security agency.

⚠ DANGER If any part of a boiler, burner or its controls has been sprayed with or submerged under water, either partially or fully, **DO NOT attempt to operate the boiler until the boiler has been either replaced or completely repaired, inspected, and you are sure that the boiler and all components are in good condition and fully reliable.** Otherwise, by operating this boiler, you will cause a fire or explosion hazard, and an electrical shock hazard, leading to serious injury, death, or substantial property damage. See the instructions at right.

Saltwater Damage — The exposure of boiler components to saltwater can have both immediate and long-term effects. While the immediate effects of saltwater damage are similar to those of freshwater (shorting out of electrical components, washing out of critical lubricants, etc.), the salt and other contaminants left behind can lead to longer term issues after the water is gone due to the conductive and corrosive nature of the salt residue. Therefore, Weil-McLain equipment contaminated with saltwater or polluted water will no longer be covered under warranty and should be replaced.

Electrical Damage — If any **electrical component** or **wiring** came into contact with water, or was suspected to have come into contact with water, replace the boiler with a new Weil-McLain boiler.



OPERATING INSTRUCTIONS

Figure 1 Operating instructions

External gas piping (by installer)

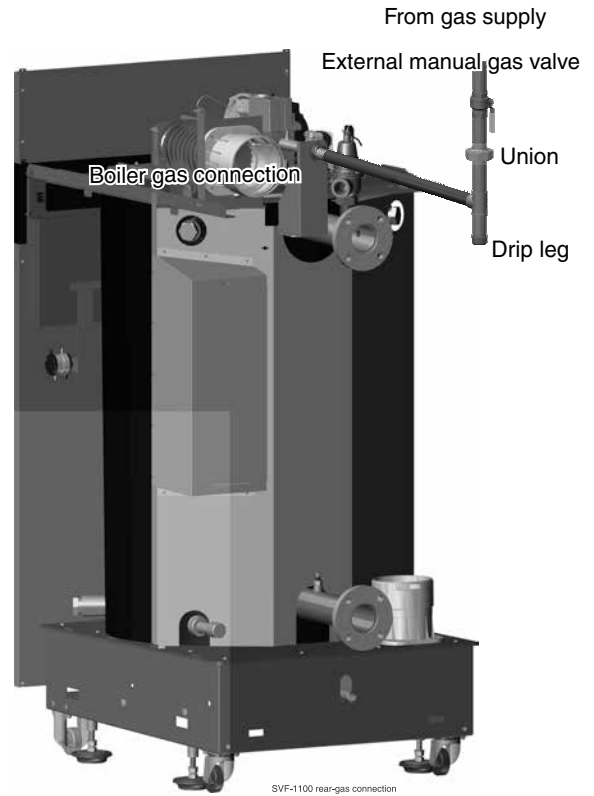

FOR YOUR SAFETY READ BEFORE OPERATING

WARNING

If you do not follow these instructions exactly, a fire or explosion may result causing property damage, personal injury or loss of life.

- A. This appliance does not have a pilot. It is equipped with an ignition device which automatically lights the burner. Do not try to light the burner by hand.
- B. Before OPERATING, smell all around the appliance area for gas. Be sure to smell next to the floor because some gas is heavier than air and will settle on the floor. See below.
- C. Use only your hand to turn the gas valve handle. Never use tools. If the handle will not turn by hand, don't try to repair it, call a qualified service technician. Force or attempted repair may result in a fire or explosion.
- D. Do not use this appliance if any part has been under water. Immediately call a qualified service technician to inspect the appliance and to replace any part of the control system and any gas control, which has been under water.

WHAT TO DO IF YOU SMELL GAS

- Do not try to light any appliance.
- Do not touch any electric switch; do not use any phone in your building.
- Immediately call your gas supplier from a neighbor's phone. Follow the gas supplier's instructions.
- If you cannot reach your gas supplier, call the fire department.

See next page for location of interior boiler manual gas valve.

OPERATING INSTRUCTIONS

1. Stop! Read the safety information at left on this label. This appliance is equipped with an ignition device which automatically lights the burner. Do not try to light the burner by hand.
2. Set room thermostat(s) to lowest setting. Verify external manual gas cock is open (valve handle parallel to gas piping).
3. Turn OFF all electrical power to the appliance.
4. Remove boiler access door.
5. Turn boiler manual gas valve handle counterclockwise ↺ to open gas supply.
6. Wait five (5) minutes to clear out any gas. Then smell for gas, including near the floor. If you smell gas, STOP! Follow "B" in the safety information to the left. If you don't smell gas, go to the next step.
7. Turn ON all electrical power to the appliance.
8. Set thermostat(s) to desired setting.
9. The display will show symbols and text describing the status of the boiler as it proceeds through its operating sequence.
10. If the appliance will not operate when there is a call for heat and piping is not hot, follow the instructions "To Turn Off Gas To Appliance" below and call your service technician or gas supplier.

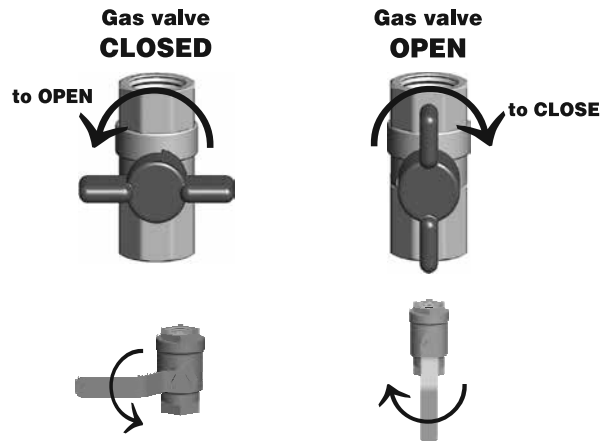

11. Reinstall boiler access door. Make sure panel is seated firmly in place.

TO TURN OFF GAS TO THE APPLIANCE

1. Set room thermostats to lowest setting.
2. Turn OFF all electrical power to the appliance.
3. Close external manual gas cock (valve handle perpendicular to gas piping). Remove boiler access door. Turn boiler manual gas valve handle clockwise ↻ to close gas supply.
4. Reinstall boiler access door.

550-101-262 (0218)



Boiler components

Figure 2 SVF™ boiler operating components, front panel removed.

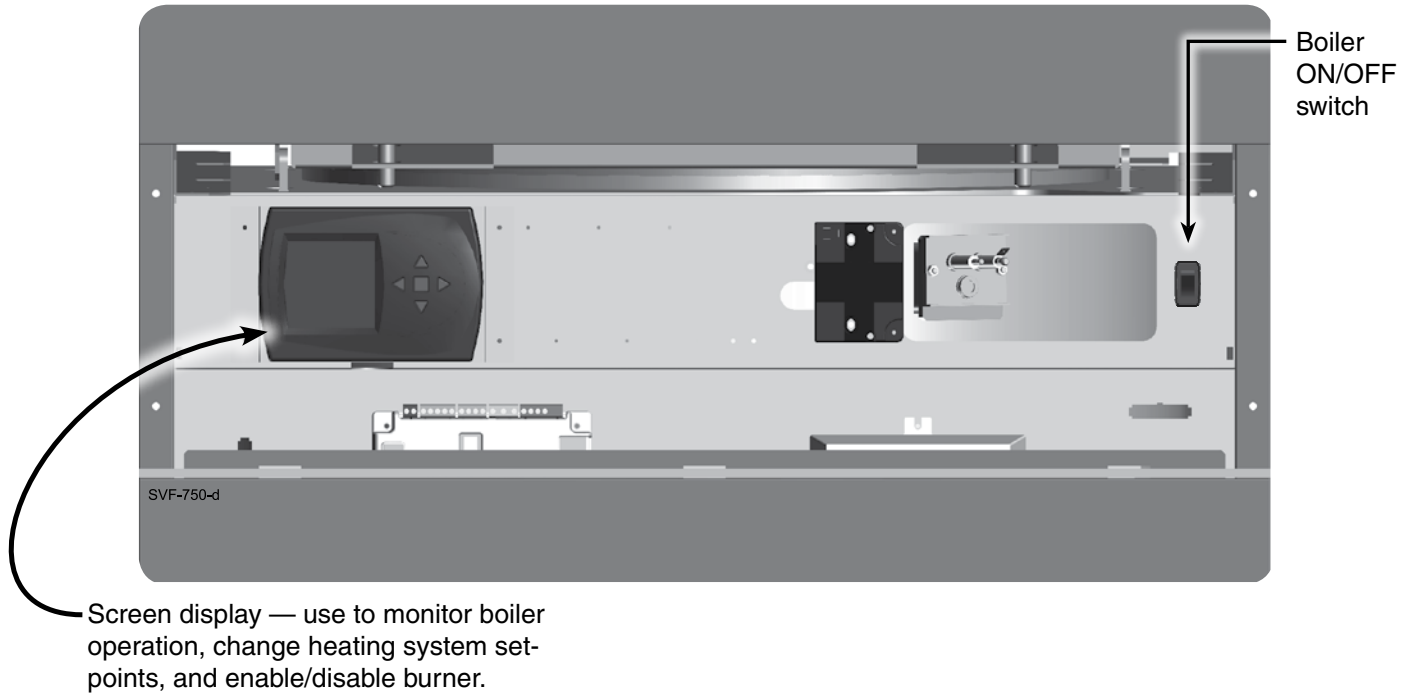
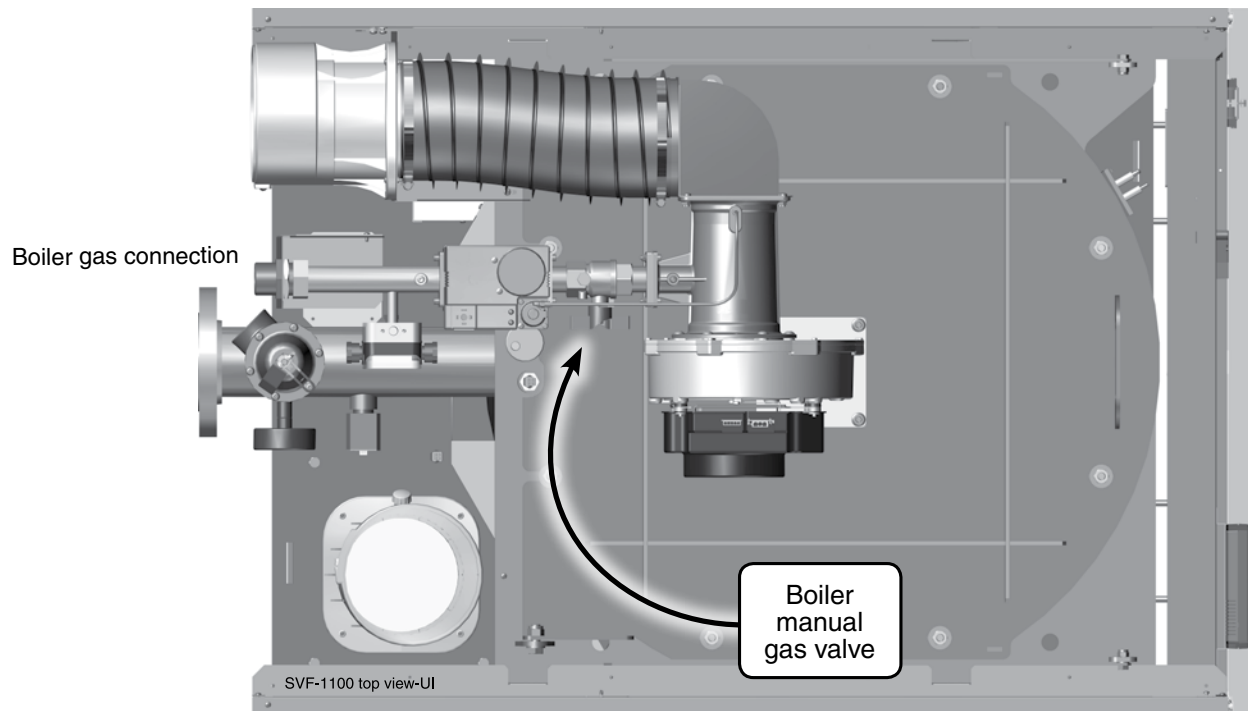

Figure 3 Boiler manual gas valve location, top panel removed





The Control display

Figure 4 SVF™ boiler's control display

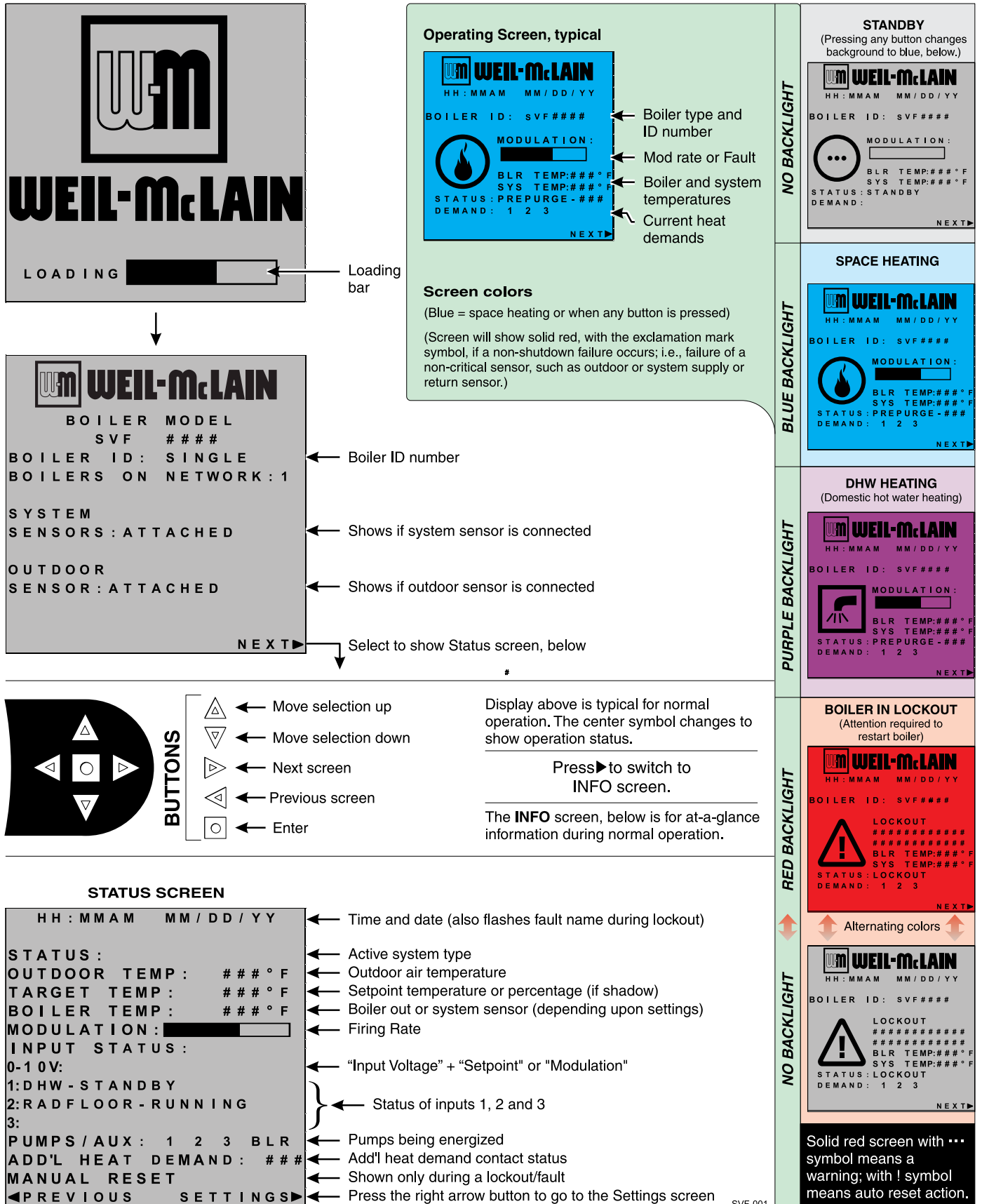



The Control display *(continued)*

Figure 5 SVF™ boiler control display **USER Menu** — (set date and time, reset faults).

BOILER STATUS screen

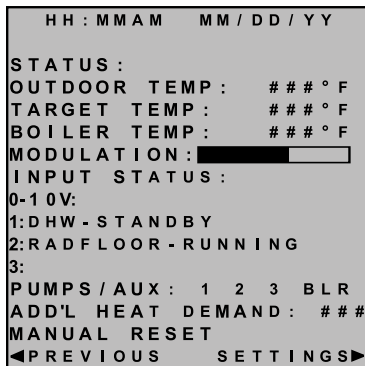

SVF-001-bs-1

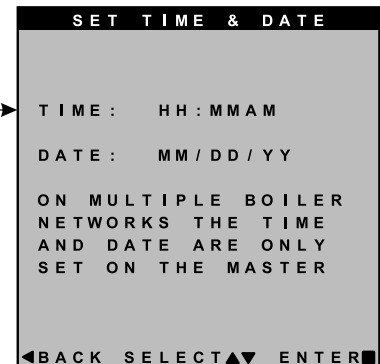

Date and time

1. Set month, date, year, hour and minutes.
2. Keeping the date and time current makes sure the control can record problems accurately.

Figure 6 SVF™ boiler control display **LOCKOUT SCREEN** — screen turns red when boiler locks out — highlight and select **MANUAL RESET** to reset boiler as shown below.

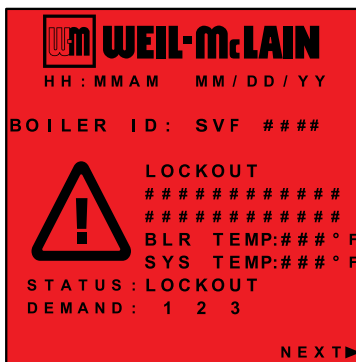

SVF-001-bs-2

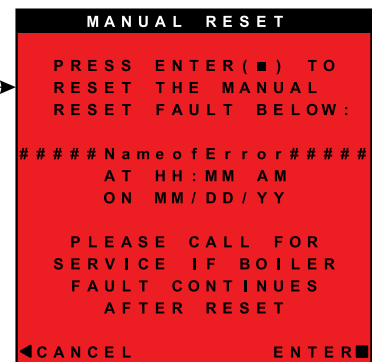
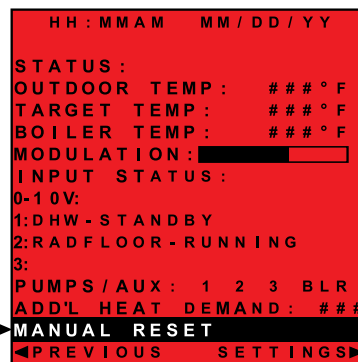

Resetting faults:

1. During a fault, the status will change to LOCKOUT and the Time & Date line will alternate with the fault name. The line MANUAL RESET will appear on the Boiler Status screen.
2. Select **MANUAL RESET** to reset fault condition.
3. The MANUAL RESET screen will indicate whether the fault was a manual or automatic reset, the fault name, and the time and date it occurred.
4. Call for service if fault continues.

Figure 7 SVF™ boiler control display **Maintenance** notice screens.

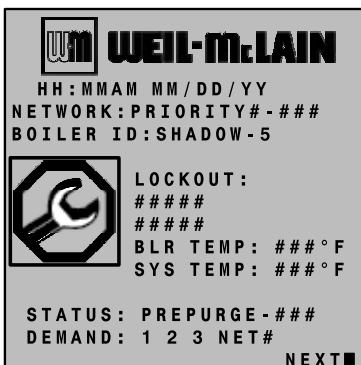

SVF-001-bs-3



The display flashes blue and shows the “Wrench” symbol to indicate a situation requiring service attention.
The screen alternates between the “Wrench” screen and the “Maintenance” screen. This only occurs during standby, not during boiler operation. Press ENTER to go to RESET REMINDER. After resetting, the control will no longer show the “Wrench” screen.





Resetting the Control

Figure 8 Control display turns red when boiler locks out — select MANUAL RESET to reset boiler as shown below.

NOTICE: Screen background color alternates from RED to no backlight (gray screen).

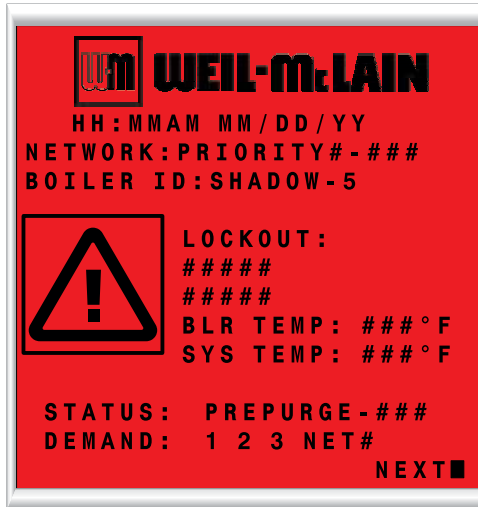

SEE TOP LINE OF DISPLAY FOR ERROR

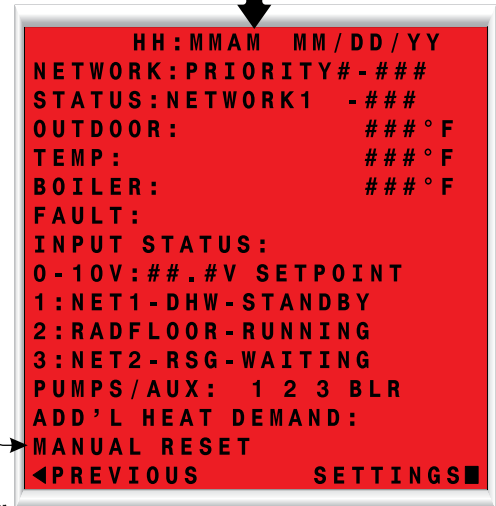

Select **MANUAL RESET** to reset condition. Make sure to correct the cause of the problem if possible.

Select **RESET REMINDER** to reset the counter. The reset reminder will not occur again until the INTERVAL time has elapsed.

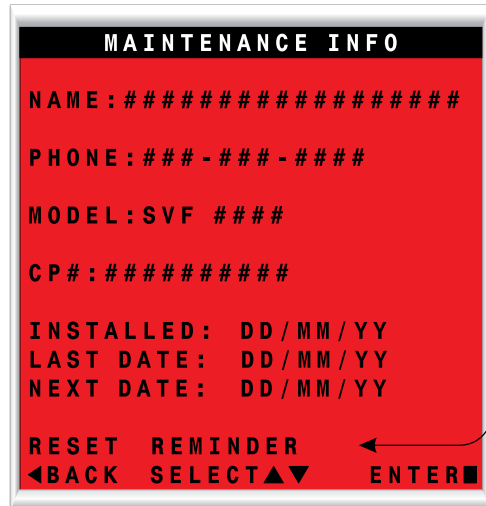

To reset:

- Press the DOWN or RIGHT arrow.
- The display will go to the STATUS screen.
- SETTINGS will be highlighted.
- Press the DOWN arrow to move down to MANUAL RESET.
- Press ENTER (center button).
- The display will switch to the manual reset screen, indicating what caused the shutdown.
- Press ENTER to reset the control.
- The control will then return to normal operation if the condition has been corrected.



Prevent combustion air contamination



If the boiler combustion air inlet is located in any area likely to cause contamination, or if products which would contaminate the air cannot be removed, you must have the combustion air and vent re-piped and terminated to another location. Contaminated combustion air will damage the boiler, resulting in possible severe personal injury, death or substantial property damage.

Do not operate an SVF™ boiler if its combustion air inlet is located in a laundry room or pool facility, for example. These areas will always contain hazardous contaminants.

Pool and laundry products and common household and hobby products often contain fluorine or chlorine compounds. When these chemicals pass through the boiler, they can form strong acids. The acid can eat through the boiler wall, causing serious damage and presenting a possible threat of flue gas spillage or boiler water leakage into the building.

Please read the information listed below. If contaminating chemicals will be present near the location of the boiler combustion air inlet, have your installer pipe the boiler combustion air and vent to another location, per the Boiler manual.

Products to avoid	Areas likely to have contaminants
Spray cans containing chloro/fluorocarbons	Dry cleaning/laundry areas and establishments
Permanent wave solutions	Swimming pools
Chlorinated waxes/cleaners	Metal fabrication plants
Chlorine-based swimming pool chemicals	Beauty salons
Calcium chloride used for thawing	Refrigeration repair shops
Sodium chloride used for water softening	Photo processing plants
Refrigerant leaks	Auto body shops
Paint or varnish removers	Plastic manufacturing plants
Hydrochloric acid/muriatic acid	Furniture refinishing areas and establishments
Cements and glues	New building construction
Antistatic fabric softeners used in clothes dryers	Remodeling areas
Chlorine-type bleaches, detergents, and cleaning solvents found in household laundry rooms	Garages with workshops
Adhesives used to fasten building products and other similar products	
Excessive dust and dirt	



Annual startup and general maintenance

Figure 9 Service and maintenance schedules

OWNER MAINTENANCE (see the following pages for instructions)	
BEGINNING OF SEASON	Contact your boiler service technician to inspect, service and start up your boiler. You must have an annual start-up performed by a qualified service technician to ensure reliable operation of the boiler and system.
DAILY	<p>Check boiler area.</p> <p>Check air openings.</p> <p>Check pressure/temperature gauge.</p> <p>Verify boiler front door is securely closed.</p>
MONTHLY	<p>Check vent piping.</p> <p>Check air piping.</p> <p>Check relief valve.</p> <p>Check condensate drain system.</p> <p>Check automatic air vents (if used).</p>
PERIODICALLY	<p>Test low water cutoff.</p> <p>Check time and date on the control display.</p>
EVERY 6 MONTHS	<p>Check boiler piping (gas and water).</p> <p>Operate relief valve.</p>
END OF SEASON	Shut boiler down (unless boiler used for domestic water).



WARNING Follow the service and maintenance procedures given throughout this manual and in component literature shipped with the boiler. Failure to perform the service and maintenance could result in damage to the boiler or system. Failure to follow the directions in this manual and component literature could result in severe personal injury, death or substantial property damage.



Maintenance and service overview

The boiler must be serviced & maintained

⚠ WARNING The boiler must be inspected and started annually, at the beginning of the heating season, by a qualified service technician.

In addition, the maintenance and care of the boiler listed on Figure 9, page 10 and explained in this manual must be performed to assure maximum boiler efficiency and reliability.

Failure to service and maintain the boiler and system could result in equipment failure, causing possible severe personal injury, death or substantial property damage.



Maintenance procedures — DAILY

Check the boiler area

▲WARNING To prevent potential of severe personal injury, death or substantial property damage, **eliminate all materials discussed below** from the boiler vicinity and from the vicinity of boiler combustion air inlet. If contaminants are found:

- Immediately remove products from the area. If they have been there for an extended period, call a qualified service technician to inspect the boiler for possible damage from acid corrosion.
- If products cannot be removed, immediately call a qualified service technician to re-pipe vent (and air) piping and locate vent termination/air intake away from contaminated areas.

Combustible/flammable materials

Do not store combustible materials, gasoline or any other flammable vapors or liquids near the boiler. Remove immediately if found.

Air contaminants

Products containing chlorine or fluorine, if allowed to contaminate the boiler intake air, will cause acidic condensate in the boiler. This will cause significant damage to the boiler if allowed to continue. Read the list of potential materials listed on page 4 of this manual. If any of these products are in the room from which the boiler takes its combustion air, they must be removed immediately or the boiler combustion air (and vent termination) must be relocated to another area.

Check the pressure/temperature gauge

1. Make sure the pressure reading on the boiler pressure/temperature gauge does not exceed 5 psig less than the relief valve setting.
2. Contact a qualified service technician if pressure is too high.

DIRECT EXHAUST installations: Verify combustion air openings are clear and flue is unobstructed

1. DIRECT EXHAUST INSTALLATIONS Visually inspect all combustion air openings.
 - a. Remove any debris or blockage from combustion air louvers.

▲WARNING The combustion air openings must be unobstructed. This is the means for combustion and ventilation air to be drawn into the boiler room.

Failure to provide proper combustion air can result in severe personal injury, death or substantial property damage.

2. Verify that boiler vent discharge is clean and free of obstructions.
3. Remove any debris on the flue exhaust openings.
4. If removing the debris does not allow the boiler to operate correctly afterwards, contact your qualified service technician to inspect the boiler and vent/air systems.

DIRECT VENT installations: Verify vent/air terminations are unobstructed (air piped to the boiler from outside)

1. Verify that boiler vent discharge and air intake are clean and free of obstructions.
2. Remove any debris on the air intake or flue exhaust openings.
3. If removing the debris does not allow the boiler to operate correctly afterwards, contact your qualified service technician to inspect the boiler and vent/air systems.



Maintenance procedures — MONTHLY

Perform DAILY procedures plus the following additional procedures . . .

Check vent piping

1. Visually inspect the flue gas vent piping for any signs of blockage, leakage or deterioration of the piping. Notify your qualified service technician at once if you find any problem.

▲WARNING Failure to inspect the vent system as noted above and have it repaired by a qualified service technician can result in vent system failure, causing severe personal injury or death.

Check air piping (DIRECT VENT installations)

1. Visually inspect the air inlet to be sure it is unobstructed. Inspect entire length of air piping to ensure piping is intact and all joints are properly sealed.
2. Call your qualified service technician if you notice any problems.

Check the relief valve

1. Inspect the boiler relief valve and the relief valve discharge pipe for signs of weeping or leakage.
2. If the relief valve often weeps, the expansion tank may not be working properly. Immediately contact your qualified service technician to inspect the boiler and system.

Check the condensate drain system

1. While the boiler is running, check the discharge end of the condensate drain tubing by holding your fingers in front of the opening.

2. If you notice flue gas escaping, this indicates a dry condensate drain trap. See step 4 for procedure to fill trap. Call your qualified service technician to inspect the boiler and condensate line and refill the condensate trap if problem persists regularly.

▲WARNING Under some circumstances an SVF™ vent system may not produce enough condensate to keep the condensate trap full of liquid. If the trap is not full, small amounts of flue products can be emitted into the boiler room through the condensate drain line. Follow procedure below to fill trap.

3. Verify that the condensate drain line is unobstructed by slowly pouring water into the exhaust sampling port on near the flue connection (piping end of the boiler). The water should run out the end of the condensate drain line. If the water does not run out, call your qualified service technician to inspect the boiler and clean or replace the condensate drain line.
4. Fill the condensate trap with fresh water, either by removing, filling and re-installing or by pouring water into the exhaust sampling port the flue connection (piping end of boiler).
5. Loosen any attachments to the supplied flexible drain hose.
 - a. Loosen the condensate trap inlet connection.
 - b. Remove condensate trap and flush as needed.

▲WARNING The condensate trap must be filled with water during all times of boiler operation to avoid flue gas emission from the condensate drain line. Failure to fill the trap could result in severe personal injury or death.

Check automatic air vents (if used)

1. See illustration at right.
2. Remove the cap from any automatic air vent in the system and check operation by depressing valve "B" slightly with the tip of a screwdriver.
3. If the air vent valve appears to be working freely and not leaking, replace cap "A", twisting all the way on.
4. Loosen cap "A" one turn to allow vent to operate.
5. Have vent replaced if it does not operate correctly.

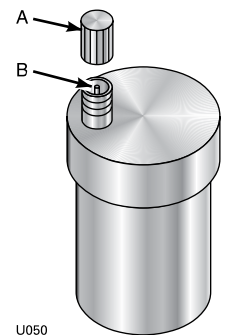

Maintenance procedures — PERIODICALLY

Perform DAILY procedures plus the following additional procedures . . .

Test the low water cutoff

1. Locate the low water cut-off on the piping end of heat exchanger.
2. Press the TEST button. **Hold the button for at least 5 seconds.** Any shorter time will result in an automatic reset instead of a manual reset.
3. The green STATUS light should change to red, indicating a low water condition.
4. The SVF™ boiler's control will shut down the boiler on manual reset.
5. The control display will flash red as shown in Figure 8, page 8.
6. Select MANUAL RESET to reset the control
7. The boiler should return to normal operation.

⚠ WARNING If the low water cutoff fails to cause a manual reset lockout condition, immediately turn off all power to the boiler and contact your boiler technician.

⚠ WARNING If the low water cutoff SERVICE light is on, contact your service technician immediately.

Figure 10 Low water cutoff

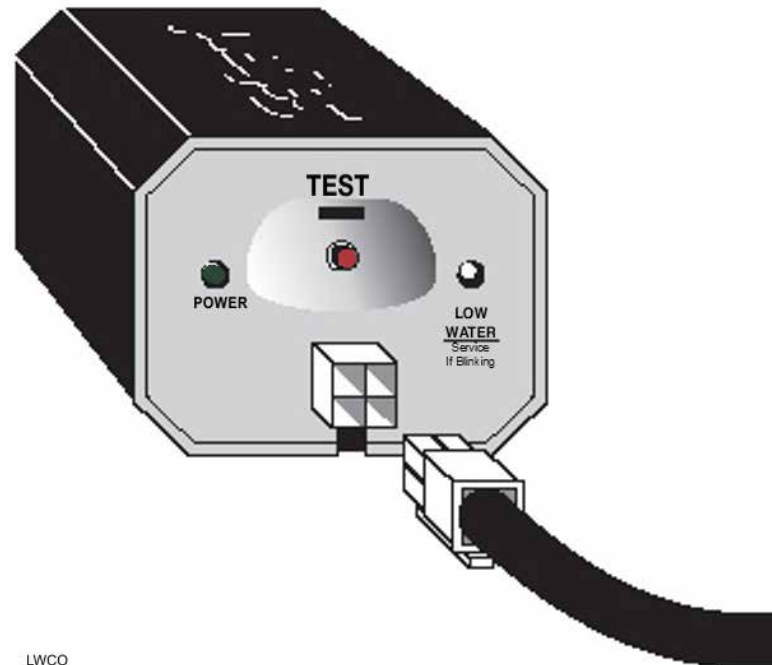

Check control date and time

1. Check the time shown on the control display (see Figure 4, page 6).
2. If time is incorrect, set the correct date and time as shown in Figure 4, page 6.



Maintenance procedures — EVERY 6 MONTHS

Perform DAILY and MONTHLY procedures plus the following additional procedures . . .

Check the boiler water and gas piping

1. Perform gas leak inspection per steps 1 through 7 of the Operating Instructions, Figure 1, page 4.
2. If gas odor or leak is detected, immediately shut down boiler following procedures in the Operating Instructions, Figure 1, page 4. Call a qualified service technician.
3. Visually inspect for leaks around internal water piping. Also inspect external water piping, circulators, relief valve and fittings. Immediately call a qualified service technician to repair any leaks.

▲WARNING Have leaks fixed at once by a qualified service technician. Failure to comply could result in severe personal injury, death or substantial property damage.

Operate the relief valve

1. Before proceeding, verify that the relief valve outlet has been piped to a safe place of discharge, avoiding any possibility of scalding from hot water.

▲WARNING To avoid water damage or scalding due to valve operation, a metal discharge line must be connected to relief valve outlet and run to a safe place of disposal. This discharge line must be installed by a qualified heating installer or service technician in accordance with the instructions in the SVF™ Boiler Manual. The discharge line must be terminated so as to eliminate possibility of severe burns or property damage should the valve discharge.

2. Read the boiler pressure/temperature gauge to make sure the system is pressurized. Lift the relief valve top lever slightly, allowing water to relieve through the valve and discharge piping.
3. If water flows freely, release the lever and allow the valve to seat. Watch the end of the relief valve discharge pipe to ensure that the valve does not weep after the line has had time to drain. If the valve weeps, lift the seat again to attempt to clean the valve seat. If the valve continues to weep afterwards, contact your qualified service technician to inspect the valve and system.
4. If water does not flow from the valve when you lift the lever completely, the valve or discharge line may be blocked. Immediately shut down the boiler, following the operating instructions on page 9. Call your qualified service technician to inspect the boiler and system.

Maintenance procedures — END OF SEASON

To continue operation for DHW

1. If the boiler is to supply heat for domestic hot water generation during the summer, no changes should be needed. Just leave the boiler power on and allow the DHW storage tank to call for heat as necessary.
2. Set back room thermostats to prevent any unnecessary call for heat during the off season.

To leave boiler in stand-by mode

1. The SVF™ boiler's control provides effective features for stand-by operation, including periodic exercising of the boiler and system circulators and automatic operation of the boiler at low fire if water temperatures drop too close to freezing. Just configure the control as needed to operate the necessary circulators.
2. Leave the boiler power on and allow the control to monitor the boiler and system during the stand-by period.

▲WARNING The control must be configured to operate all circulators needed to ensure the system and all circuits will be protected against freezing. See the SVF™ Commercial Boiler manual for details.

3. Set back room thermostats to prevent any unnecessary call for heat during the off season.

To shut down the boiler

1. Follow "TO TURN OFF GAS TO APPLIANCE" of the Operating Instructions, Figure 1, page 4.
2. DO NOT drain the system unless exposure to freezing temperatures will occur.
3. DO NOT drain the system if it is filled with an antifreeze solution.
4. DO NOT shut down boilers used for domestic water heating. They must operate year-round.

