

Electromechanical Level Control

Class 9036, 9037, and 9038
and Class 9049 Accessories

Catalog
9034CT9701R2/08

08



CONTENTS

Description	Page
Selection Guide	4
Introduction	16
9036 D and G	20
9036 FG	23
9037 E and H	24
9038 A, C, and D	30



Electromechanical Level Control Table of Contents

<i>Selection guide</i>	<i>page 4</i>
Introduction	<i>page 16</i>
Class 9036 Open Type	<i>page 20</i>
Class 9037 Closed Type	<i>page 24</i>
Class 9038 Mechanical Alternators	
■ Open Type	<i>page 30</i>
■ Closed Type	<i>page 32</i>
Class 9049 Accessories	<i>page 38</i>
Class 9998 Renewal Parts	<i>page 38</i>

Electromechanical Level Control

Class 9036 Type D—Open Tank, General Purpose

Selection Guide

Type of Installation	Horsepower rated		
Product features	2-pole switch, lever operated Standard action—contacts close; reverse action—contacts open		
			
Fluids Controlled	Water, hydraulic oils, corrosive fluids		
Fluids Characteristics	Fresh water, sea water, hydraulic oils, and corrosive fluids with a density ≥ 0.8		
Contact Arrangement	Standard: 2 N.O. (DPST). Form R: 2 N.C. (DPST). Form H: 1 N.O. and 1 N.C. (SPDT).		
Degree of Protection	NEMA Type 1	NEMA Type 4	NEMA Type 7 and 9
Electrical Connection	4 screw terminals, 1/2 in. NPT entry		
Ambient Temperature	-22 to +220 °F (-30 to +105 °C)		
Catalog numbers	9036DG	9036DW	9036DR
Pages	page 20		

Accessory Kits	Tapped-at-Top Floats (#304 SS) ★			Center-Hole Floats (#304 SS) ◆			Additional Tubing ▲		
									
Tubing (rods)	5 ft brass	5 ft Al	5 ft SS	5 ft brass	5 ft Al	5 ft SS	2.5 ft brass	2.5 ft Al	2.5 ft SS
Net buoyancy in water, 7 in. float ■	60	60	60	70	70	70	—	—	—
Total weight of stops, oz (g)	3 (85)	3 (85)	3 (85)	6 (170)	6 (170)	6 (170)	—	—	—
Number of stops	2	2	2	4	4	4	—	—	—
Weight of the included 5 ft rod, oz (g)	18.5 (524)	6 (170)	16.9 (479)	18.5 (524)	6 (170)	16.9 (479)	—	—	—
Weight per ft of extra rod, oz (g)	3.7 (105)	1.2 (34)	3.4 (96)	3.7 (105)	1.2 (34)	3.4 (96)	3.7 (105)	1.2 (34)	3.4 (96)
Catalog numbers	9049A6	9049A6A	9049A6S	9049A6C	9049A6CA	9049A6CS	9049T1	9049T1A	9049T1S
Pages	page 21								

- Net buoyancy calculated with the float 80% submerged, allowing for a 20% operating margin. Buoyancy data calculated for use in water. Consult your local Square D® field office for buoyancy data in media having specific gravity different than water (1.0).
- ▲ Additional tubing kits add on to float accessory kits and include a connector.
- ★ Maximum recommended tubing length for tapped-at-top float: 12.5 ft (3810 mm).
- ◆ Maximum recommended tubing length for center-hole float: 30 ft (9144 mm).

When ordering float accessories, first specify the desired accessory kit, then as a second item, give the catalog number and the quantity of the additional tubing kits required. For example, for a 9049A6C kit with 15 ft of tubing, specify:

- A. 9049A6C, quantity = 1 (includes 5 ft of tubing)
- B. 9049T1, quantity = 4 (2.5 ft of tubing each, for a total of 10 additional ft)

Compensating Spring

Compensating springs are used to support the weight of long rods that cannot be supported by center-hole floats.

<p>Calculation example Measuring 15 ft of tank depth</p> <p><i>System has 15 ft of brass rod, 4 stops, and a center hole float.</i></p> <p>Buoyancy is positive, so no compensating spring is required</p>	• Float buoyancy	70.0 oz
	• Total Weight	(61.5 oz)
	Weight of stops:	(6.0 oz)
	Weight of 5 ft of brass rod (included):	(18.5 oz)
	Weight of 10 ft of brass rod (separate):	(37.0 oz)
• Buoyancy	8.5 oz	

Electromechanical Level Control

Class 9036 Type G—Open Tank, Heavy Duty

Selection Guide

Type of Installation
Product features

Horsepower rated
2-pole switch; standard action—contacts close; reverse action—contacts open



Fluids Controlled	Water, hydraulic oils, corrosive fluids		
Fluids Characteristics	Fresh water, sea water, hydraulic oils, and corrosive fluids with a density ≥ 0.8		
Contact Arrangement	Standard: 2 N.O. (DPST). Form R: 2 N.C. (DPST). Form H: 1 N.O. and 1 N.C. (SPDT).		
Degree of Protection	NEMA Type 1	NEMA Type 4	NEMA Type 7 and 9
Electrical Connection	4 screw terminals, 1/2 in. NPT entry	4 screw terminals, 3/4 in. NPT entry	
Ambient Temperature	-22 to +220 °F (-30 to +105 °C)		
Catalog numbers	9036GG	9036GW	9036GR
Pages	page 20		

Accessory Kits	Tapped-at-Top Floats (#304 SS) ★			Center-Hole Floats (#304 SS) ◆			Additional Tubing ▲		
									
Tubing (rods)	5 ft brass	5 ft Al	5 ft SS	5 ft brass	5 ft Al	5 ft SS	2.5 ft brass	2.5 ft Al	2.5 ft SS
Net buoyancy in water, 7 in. float ■	60	60	60	70	70	70	—	—	—
Total weight of stops, oz (g)	3 (85)	3 (85)	3 (85)	6 (170)	6 (170)	6 (170)	—	—	—
Number of stops	2	2	2	4	4	4	—	—	—
Weight of the included 5 ft rod, oz (g)	18.5 (524)	6 (170)	16.9 (479)	18.5 (524)	6 (170)	16.9 (479)	—	—	—
Weight per ft of extra rod, oz (g)	—	—	—	—	—	—	3.7 (105)	1.2 (34)	3.4 (96)
Catalog numbers	9049A6	9049A6A	9049A6S	9049A6C	9049A6CA	9049A6CS	9049T1	9049T1A	9049T1S
Pages	page 21								

- Net buoyancy calculated with the float 80% submerged, allowing for a 20% operating margin. Buoyancy data calculated for use in water. Consult your local Square D field office for buoyancy data in media having specific gravity different than water (1.0).
- ▲ Additional tubing kits add on to float accessory kits and include a connector.
- ★ Maximum recommended tubing length for tapped-at-top float: 12.5 ft (3810 mm).
- ◆ Maximum recommended tubing length for center-hole float: 30 ft (9144 mm).

When ordering float accessories, first specify the desired accessory kit, then as a second item, give the catalog number and the quantity of the additional tubing kits required. For example, for a 9049A6C kit with 15 ft of tubing, specify:

- A. 9049A6C, quantity = 1 (includes 5 ft of tubing)
- B. 9049T1, quantity = 4 (2.5 ft of tubing each, for a total of 10 additional ft)

Compensating Spring



Compensating springs are used to support the weight of long rods that cannot be supported by center-hole floats.

<p>Calculation example Measuring 15 ft of tank depth</p> <p><i>System has 15 ft of brass rod, 4 stops, and a center hole float.</i></p> <p>Buoyancy is positive, so no compensating spring is required</p>	• Float buoyancy	70.0 oz
	• Total Weight	(61.5 oz)
	Weight of stops:	(6.0 oz)
	Weight of 5 ft of brass rod (included):	(18.5 oz)
	Weight of 10 ft of brass rod (separate):	(37.0 oz)
• Buoyancy	8.5 oz	

Electromechanical Level Control

Class 9036 Type FG—Open Tank, Pedestal Style

Selection Guide

Type of Installation Product features	Horsepower rated 2-pole switch, forward or reversing Contacts open or close on liquid rise (field convertible)		
			
Fluids Controlled	Water, hydraulic oils, corrosive fluids		
Fluids Characteristics	Fresh water, sea water, hydraulic oils, and corrosive fluids with a density ≥ 0.8		
Contact Arrangement	2 N.O. or 2 N.C., DPST, depending on rod connection		
Degree of Protection	NEMA Type 1		
Electrical Connection	4 screw terminals, 1/2 in. NPT entry		
Ambient Temperature	-22 to +220 °F (-30 to +105 °C)		
Catalog numbers	9036FG	9049A60	9049A61
Description	2-pole, pedestal-style sump pump switch	Plastic, center-hole float	33.75 in. aluminum rod, 2 float stop assemblies, and attaching hardware
Pages	page 23		

Description	Mounting plate
Product features	Pedestal mount



Material	Cold rolled steel
Finish	Painted, powder coated
Mounting connection	Threaded to accept 1 in. diameter iron pipe
Catalog numbers	9049UMS1
Pages	page 38

Figure 1: 9049UMS1 Dimensions

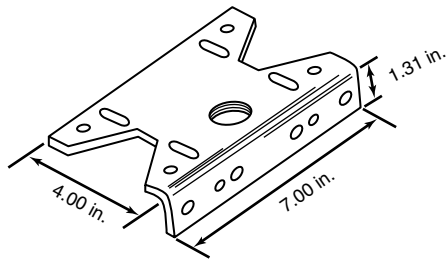

Electromechanical Level Control

Class 9037 Type E—Closed Tank, Flange Mounted

Selection Guide

Type of Installation	Horsepower rated
Product features	2-pole switch; standard action—contacts close on liquid rise; reverse action—contacts open on liquid rise



Fluids Controlled	Water, hydraulic oils, corrosive fluids		
Fluids Characteristics	Fresh water, sea water, hydraulic oils, and corrosive fluids with a density ≥ 0.8		
Contact Arrangement	Standard: 2 N.O. (DPST). Form R: 2 N.C. (DPST).		
Degree of Protection	NEMA Type 1	NEMA Type 4	NEMA Type 7 and 9
Electrical Connection	4 screw terminals, 1/2 in. NPT entry		
Ambient Temperature	-22 to +220 °F (-30 to +105 °C)		
Catalog numbers	9037EG	9037EW	9037ER
Pages	page 24		

NOTE: For float and rod kits, refer to page 15.

Type of Installation	Horsepower rated		
Product features	2-pole switch; standard action—contacts close on liquid rise; reverse action—contacts open on liquid rise		
			
Fluids Controlled	Water, hydraulic oils, corrosive fluids		
Fluids Characteristics	Fresh water, sea water, hydraulic oils, and corrosive fluids with a density ≥ 0.8		
Contact Arrangement	Standard: 2 N.O. (DPST). Form R: 2 N.C. (DPST). ⁽¹⁾		
Degree of Protection	NEMA Type 1	NEMA Type 4	NEMA Type 7 and 9
Electrical Connection	4 screw terminals, 1/2 in. NPT entry		
Ambient Temperature	-22 to +220 °F (-30 to +105 °C)		
Catalog numbers	9037HG	9037HW	9037HR
Pages	page 28		

⁽¹⁾ NEMA Type 1 devices can be field modified for reverse action. NEMA Type 4, 7, and 9 devices **cannot** be field modified for reverse action.

Electromechanical Level Control

Class 9038 Type A—Mechanical Alternator, Open Tank

Selection Guide

Type of Installation	Horsepower rated		
Product features	4-pole switch; standard action—contacts close; reverse action—contacts open		
			
Fluids Controlled	Water, hydraulic oils, corrosive fluids		
Fluids Characteristics	Fresh water, sea water, hydraulic oils, and corrosive fluids with a density ≥ 0.8		
Contact Arrangement	4 N.O. (2 DPST)		
Degree of Protection	NEMA Type 1	NEMA Type 4	NEMA Type 7 and 9
Electrical Connection	8 screw terminals, 1/2 in. or 3/4 in. NPT entry		
Ambient Temperature	-22 to +220 °F (-30 to +105 °C)		
Catalog numbers	9038AG	9038AW	9038AR
Pages	page 30		

Electromechanical Level Control Class 9038 Type C—Mechanical Alternator, Closed Tank

Type of Installation	Horsepower rated		
Product features	4-pole switch; standard action—contacts close; reverse action—contacts open		
			
Fluids Controlled	Water, hydraulic oils, corrosive fluids		
Fluids Characteristics	Fresh water, sea water, hydraulic oils, and corrosive fluids with a density ≥ 0.8		
Contact Arrangement	4 N.O. (2 DPST), alternating contacts		
Degree of Protection	NEMA Type 1	NEMA Type 4	NEMA Type 7 and 9
Electrical Connection	8 screw terminals, 1/2 in. or 3/4 in. NPT entry		
Ambient Temperature	-22 to +220 °F (-30 to +105 °C)		
Catalog numbers	9038CG	9038CW	9038CR
Pages	page 32		

Electromechanical Level Control

Class 9038 Type D—Mechanical Alternator, Closed Tank

Selection Guide

Type of Installation	Horsepower rated		
Product features	4-pole switch; standard action—contacts close; reverse action—contacts open		
			
Fluids Controlled	Water, hydraulic oils, corrosive fluids		
Fluids Characteristics	Fresh water, sea water, hydraulic oils, and corrosive fluids with a density ≥ 0.8		
Contact Arrangement	4 N.O. (2 DPST)		
Degree of Protection	NEMA Type 1	NEMA Type 4	NEMA Type 7 and 9
Electrical Connection	4 screw terminals, 1/2 in. or 3/4 in. NPT entry, 3/4 in. NPT		
Ambient Temperature	-22 to +220 °F (-30 to +105 °C)		
Catalog numbers	9038DG	9038DW	9038DR
Pages	page 34		

Electromechanical Level Control Class 9049 Kits for Class 9038 Type D and Class 9037 Type E

Type of Installation Kit	Float Kits				Float Rod Kits							
Material	#304 SS	#316 SS	#304 SS	#316 SS								
Dimensions, in. (mm) Diameter x Length	3.625 x 4.5 (92 x 114)	3.625 x 4.5 (92 x 114)	2.5 x 7 (64 x 178)	2.5 x 7 (64 x 178)	—	—	—	—	—	—	—	—
R Dimension, in. (mm)	—	—	—	—	1.75 (44)	2.50 (64)	3.25 (83)	5.25 (133)	7.25 (184)	12.25 (311)		
H Dimension, in. (mm)	—	—	—	—	8.25 (210)	9.00 (229)	9.50 (241)	11.75 (298)	13.75 (349)	18.75 (476)		
Catalog numbers	9049EF1	9049EF2	9049HF3	9049HF4	9049ER1	9049ER2	9049ER3	9049ER5	9049ER7	9049ER12		
Pages	pages 24, 34, 38				pages 26–27, 35–38							

Figure 2: Float and Rod Kits

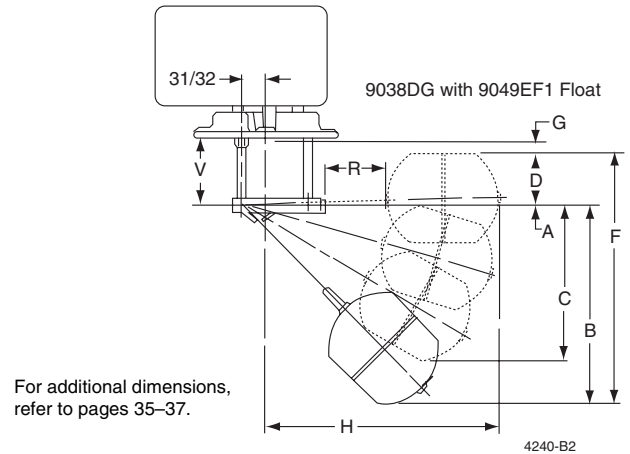

Square D® Level Control Products



9036DG2

Square D brand offers a wide range of electromechanical level control products. The current offering is described below:

- **Class 9036, Open Tank**
- **Class 9037, Closed Tank**
- **Class 9038, Mechanical Alternators**

NOTE: The Class 9039 Duplex Controller (electrical alternator) is also available but is not covered in this catalog.



9036GG

Class 9036 Open Tank

Type D and G

The Class 9036 Type D and G float switches are lever operated and designed for open tank applications. These switches are floor mounted, or they can be pedestal mounted using mounting plate 9049UMS1. They are available in NEMA Type 1, NEMA Type 4, or NEMA Type 7 and 9 enclosures.

Type FG

The Class 9036 Type FG30 pedestal-style sump pump switch is designed for liquid level control with electric-motor operated pumps either directly or through a magnetic starter. It can also be used to activate alarms in liquid level control systems. The upward or downward movement of the lever arm of the float switch controls the On and Off positions corresponding to the water levels changes required to turn the pump or alarm on and off.

NOTE: The rod for this device is 33.75 in. long. It cannot be lengthened.



9036FG
9049A60
9049A61

Class 9037 Closed Tank**Type E**

9037E

The Class 9037 Type E switches are flange mounted. Float movement is transmitted through a quad ring seal. Each switch consists of a basic switch, float rod, and float. The switch can be configured in the field for contacts that open on liquid rise or close on liquid rise. These switches are used for top mounted or side mounted, closed tank applications.

Type H

9037H

The Class 9037 Type H switches are attached to the tank by means of a 2-1/2 in. bushing. An external pointer indicates the float position within the tank when the unit is mounted. Switches come complete with stainless steel float and rod. A nitrile rubber seal, such as a Buna-N quad ring seal, is used between the float rod and the sealing connector. Normal application is at atmospheric pressure. Where higher pressures are encountered, the available Viton® seal allows the switch to withstand tank pressures up to 50 psi at ambient temperatures up to 220 °F. Occasional replacement of the quad ring seal may be necessary.

Class 9038 Mechanical Alternators**Type A (Open Tank)**

9038AG1

The Class 9038 Type A Open Tank level switch is a mechanical alternator designed to provide motor alternation in the operation of two motors.

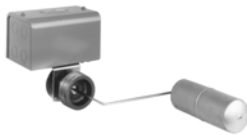
Type C (Closed Tank, Bushing Mounted)

9038CG

The Class 9038 Type C Closed Tank level switches are bushing mounted. Float movement is transmitted through a quad ring seal. Each switch consists of a basic switch, rod, and float.

Type C switches are attached to the tank by means of a 2-1/2 in. bushing. An external pointer indicates the float position within the tank when the unit is mounted. Switches come complete with bushing, stainless steel float, and rod.

Occasional replacement of the quad ring may be necessary.

Type D (Closed Tank, Flange Mounted, Top)9038DG
9049ER5
9049EF1

Type D mechanical alternators are designed for applications where flange mounting is to be made at the top of a closed tank.



9036DG2



9036GG2

Selecting a Float Switch

Standard float switches have two contacts that close when the liquid rises above the designated level. This contact configuration is used for tank emptying applications. Float switches are also available with reverse (Form R) and double throw (Form H) contacts. Form R switches, used for tank filling applications, have two contacts that open when the liquid rises above the designated level. Form H switches, which can be used for both applications, have one normally open (N.O.) and one normally closed (N.C.) contact.

To select the proper Square D float switch, determine the following:

- Type and shape of tank (open, closed, sump, etc.)
- Enclosure requirements
 - **NEMA Type 1:** For general purpose applications intended for indoor use.
 - **NEMA Type 4:** For watertight and dusttight applications for either indoor or outdoor use.
 - **NEMA Type 7 and 9:** For explosion proof applications. Suitable for Class I, Division 1 and 2, Groups C and D and Class II, Division 1 and 2, Groups E, F, and G hazardous locations.
- Total level change required
- Mounting requirements (such as flange mounting or screw-in bushing)
- Horsepower, phase, and voltage requirements
- Float material
 - Stainless steel (SS)
 - Plastic (available on 9036FG30 and as a Form for use with diesel fuel)
- Rod material
 - Brass
 - Stainless steel (SS)
 - Aluminum (Al)

In direct motor control applications, float switch ratings must be greater than or equal to the pump motor ratings.

NOTE: Consult your local Square D field office when using float switches in liquids with a specific gravity different than water (1.0).

The following information must be included for each float switch ordered:

- Basic switch: Class and Type
- Accessory kits: Class and Type

Selecting Floats and Rods

Class 9036 and Class 9038 Type A float switches are actuated with the Class 9049 Type A line of accessories. Select the float and rod material according to the corrosiveness of the liquid used in the application. Two types of float kits are offered:

- Tapped-at-top float (Class 9049 Type A6, A6S, and A6A)
- Center-hole float (Class 9049 Type A6C, A6CS, and A6CA)

The tapped-at-top float is for applications requiring short lengths of tubing and small liquid level changes. The maximum tubing length is 12 ft (3.66 m). Adequate space must be available to allow for ceiling clearance when the level changes. The float must be buoyant enough to lift the tubing, stop collars, and switch lever. The rod has two stops, one above and one below the switch lever. The position of the stops determines the amount of water level change.

The center-hole float is used in applications requiring long lengths of tubing and large liquid level changes. A compensating spring, used for longer lengths of tubing, supports the weight of the tubing and stops. When a compensating spring is used, the float must be buoyant enough to lift up the switch lever and heavy enough to trip the switch lever down. The rod has four stops. The position of the stops on the rod above and below the float determines the amount of water level change.

Temperature Ratings

Table 1: Temperature Limitations For All Float Switches

Ambient	Min.	-30 °C (-22 °F)
	Max.	105 °C (220 °F)

Electrical Ratings

Table 2: Class 9036, 9037, and 9038 Electrical Ratings

Class	Type	Single Phase AC Ratings (hp)			Polyphase AC Ratings (hp)			DC (hp)			Control Circuit Rating
		115 V	230 V	460/575 V	115 V	230 V	460/575 V	32 V	115 V	230 V	
9036	D (2 pole)	2	3	—	3	5	1	0.25	0.5	0.5	A600
	G (2 pole)	2	3	5	3	5	5	0.5	1	1	A600
	G Form H (1 N.O., 1 N.C.)	1	2	2	—	—	—	—	0.5	0.5	A300
9037	E, H (2 pole)	2	3	—	3	5	1	0.25	0.5	0.5	A600
9038	All (2 pole)	2	3	—	3	5	1	0.25	0.5	0.5	A600

The following float switches are UL Listed under file E12158, CCN NKPZ:

- Class 9036 Types DG, DW, GG, GW
- Class 9037 Types EG, EW, HG, HW
- Class 9038 Types AG, AW, CG, CW, DG, DW



The following float switches are UL Listed under file E12443, CCN NOWT:

- Class 9036 Types DR, GR
- Class 9037 Types ER, HR



Class 9038 Electrical Ratings

Table 3: Control Duty Circuit Ratings (Form N5 or N25 only)



Contacts	AC—50 or 60 Hz						DC			AC or DC
	V	Inductive, 35% Power Factor				Resistive, 75% Power Factor	V	Inductive and Resistive		Continuous Carrying Amperes
		Make		Break				Make and Break Amperes	Make and Break Amperes	
		A	VA	A	VA	Single Throw			Double Throw	
SPDT Form N5	120	60	7200	6	720	6	120	0.55	0.22	10
	240	30	7200	3	720	3	250	0.27	0.11	10
	480	15	7200	1.5	720	1.5	600	0.10	—	10
	600	12	7200	1.2	720	1.2	—	—	—	—
DPDT Form N25	120	60	7200	6	720	6	125	0.22	0.22	10
	240	30	7200	3	720	3	250	0.11	0.11	10
	480	15	7200	1.5	720	1.5	600	—	—	10
	600	12	7200	1.2	720	1.2	—	—	—	—

Class 9036 Type D and G Open Tank Float Switches

Table 4 lists Class 9036 float switches and modifications.

- When ordering a **factory installed modification**, add the Form number to the end of the float switch catalog number. For example, to select a 9036DG2 switch with reverse action, order 9036DG2R.
- **Field installed modifications**, when available, are ordered as kits.

Table 4: Class 9036 Float Switches

Specifications				
Description	2-pole, single-lever operated float switches			
Applications	Open industrial tanks and sump applications			
	General Purpose	Heavy Duty		
				
Catalog Numbers				
Contact Action	Close on Liquid Rise	Open on Liquid Rise	Close on Liquid Rise	Open on Liquid Rise
NEMA Type 1 ■	9036DG2	9036DG2R	9036GG2	9036GG2R
NEMA Type 4	9036DW31	9036DW31R	9036GW1 ▲	9036GW1R ▲
NEMA Type 7 and 9	9036DR31	9036DR31R	9036GR1 ▲	9036GR1R ▲

- Contact action can be converted in the field by installing the appropriate float rod lever.
- ▲ Compensating spring standard. Use center-hole float accessories.

A **compensating spring** supports the weight of long rods that cannot be supported by center-hole floats. A compensating spring is standard on Types GR and GW, and can be ordered as a modification (Form C) on other Class 9036 Type D and G float switches.

Modifications	Factory Installed	Field Installed
	Class 9036 Form	Kit Catalog Number
For Type D (General Purpose)		
Reverse action (Type DG)	R	9049A58
Compensating spring (Type DG)	C	9049A19
Compensating spring (Types DR and DW)	C	9049A20
Compensating spring and reverse action (Types DG, DR, and DW)	CR	Not Available
For Type G (Heavy Duty)		
Reverse action ★	R	Not Available
Compensating spring (Type GG) ●	C	9049A13
Compensating spring and reverse action (Type GG)	CR	9049A13
1 N.O.—1 N.C. contact configuration	H	Not Available
Compensating spring and 1 N.O.—1 N.C. contact configuration (Type GG)	CH	Not Available

- ★ Type GG is field convertible without the use of a kit. Types GR and GW are not field convertible.
- Compensating spring standard on Types GR and GW.

Table 5 lists the trip forces and compensating spring requirements for Class 9036 Type D and G float switches. The trip force can be adjusted on the Type G switches by changing the lever length position.

Table 5: Maximum Trip Forces for Class 9036 Float Switches

Class 9036 Type and Form	DG2	DG2R	DW31	DW31R	DR31	DR31R	GG2		GG2R		GR1, GW1			
Lever Length Position	—	—	—	—	—	—	Short	Long	Short	Long	Short	Medium	Long	
Force Up to Trip (oz)	9	8	8	8	8	8	33	21	30	22	24	22	20	
Force Down to Trip (oz)	8	8	8	8	8	8	39	27	24	16	31	29	27	
Maximum Supported Weight (oz)	Without Compensating Spring	6	4	5	5	5	5	25	13	18	11	19	17	16
	With Compensating Spring	60	60	66	66	66	66	■	100	■	150	80	72	64

■ The compensating spring is not effective in combination with Short lever length position.

Figure 3: Lever Length

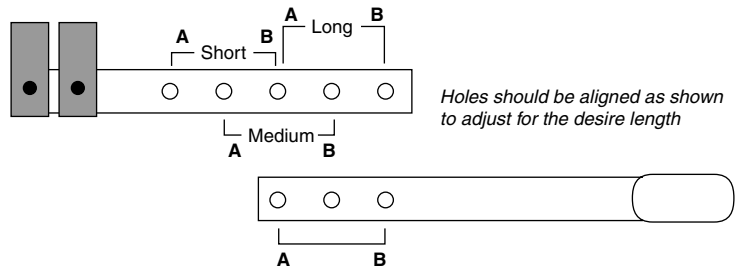

Table 6 lists Class 9049 accessory kits, which are ordered separately from the Class 9036 Type D and G float switches. A **float kit** is required; a tubing kit and replacement float do not provide all needed parts.

Table 6: Class 9049 Accessories for Class 9036 Type D and G Float Switches (weight in oz)

Accessory Kits	Tapped-at-Top Floats (#304 SS)			Center-Hole Floats (#304 SS)★			Additional Tubing (#303 SS)▲		
Used on Class 9036 Float Switch Types	All Except GW, GR, and Form C			GW, GR, and Form C			All		
Catalog Number	9049A6	9049A6A	9049A6S	9049A6C	9049A6CA	9049A6CS	9049T1	9049T1A	9049T1S
Tubing (rod)	5 ft brass	5 ft Al	5 ft SS	5 ft brass	5 ft Al	5 ft SS	2.5 ft brass	2.5 ft Al	2.5 ft SS
Net buoyancy in water, 7 in. float ■	60	60	60	70	70	70	—	—	—
Combined weight of stops	3	3	3	6	6	6	—	—	—
Number of stops	2	2	2	4	4	4	—	—	—
Weight of 5 ft rod, included	18.5	6	16.9	18.5	6	16.9	—	—	—
Weight per ft of extra rod	3.7	1.2	3.4	3.7	1.2	3.4	3.7	1.2	3.4

■ Net buoyancy calculated with float 80% submerged, allowing for a 20% operating margin. Buoyancy data calculated for use in water. Consult your local Square D field office for buoyancy data in media having specific gravity different than water (1.0).

★ Require the use of the 9049A6, 9049A6A, or 9049A6S kit. The additional tubing only attaches to other lengths of tubing.

▲ Additional tubing kits add on to the float accessory kits and include a connector.

Maximum recommended tubing length: **Tapped-at-top** float: 12.5 ft (3810 mm); **Center-hole** float: 30 ft (9144 mm).

When ordering, first specify the desired accessory kit, then as a second item give the number of additional tubing kits required. For example, to get a 9049A6C kit with 15 ft of tubing, specify:

A. 9049A6C, quantity = 1 (includes 5 ft of tubing)

B. 9049T1, quantity = 4 (2.5 ft of tubing each, for a total of 10 additional ft)

Calculation example		
Measuring 15 ft of tank depth	• Float buoyancy	70.0 oz
<i>System has 15 ft of brass rod, 4 stops, and a center hole float.</i>	• Total Weight	(61.5 oz)
Buoyancy is positive, so no compensating spring is required	Weight of stops:	(6.0 oz)
	Weight of 5 ft of brass rod (included):	(18.5 oz)
	Weight of 10 ft of brass rod (separate):	(37.0 oz)
	• Buoyancy	8.5 oz

Figure 4: Type DG Dimensions

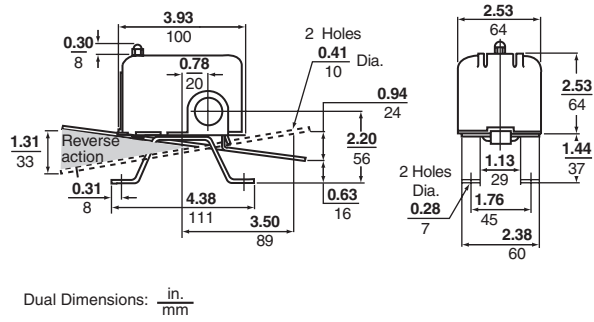

Dual Dimensions: $\frac{\text{in.}}{\text{mm}}$

Figure 5: Types DR/DW Dimensions

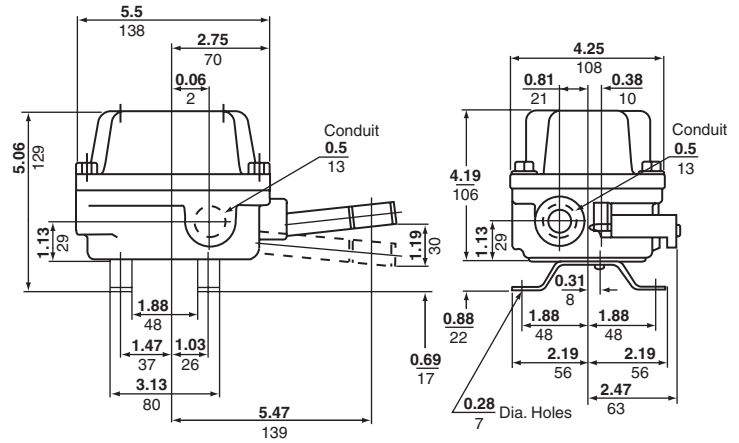

Figure 6: Type GG Dimensions

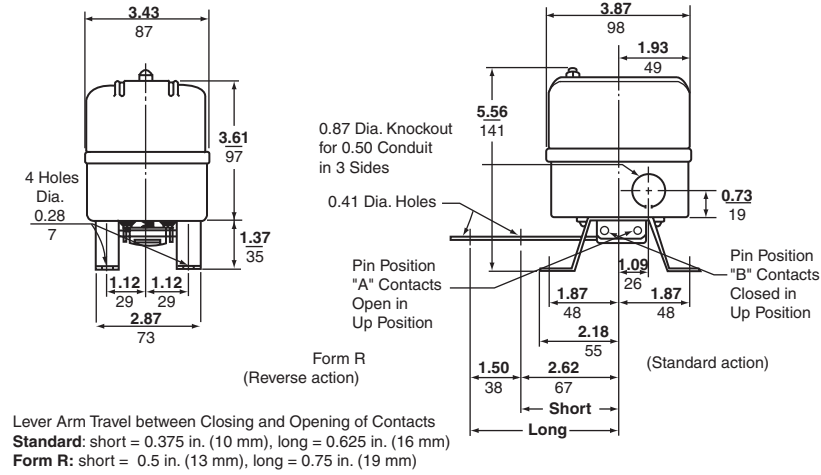
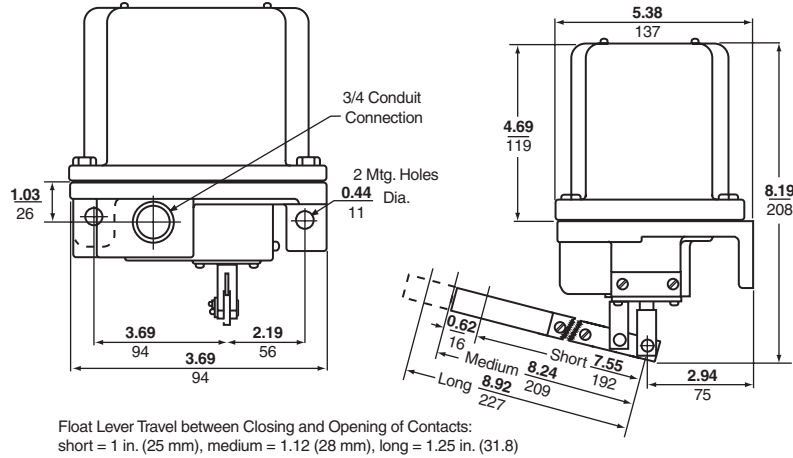

Figure 7: Types GR/GW Dimensions



Class 9036 Type FG

Class 9036 Type FG30 pedestal-style sump pump switches provide:

- Liquid level control with pumps operated by an electric motor, either directly or through a magnetic starter
- Activation of alarms in liquid level control systems
- Forward or reverse action (field selectable)

The upward or downward movement of the lever arm controls the On and Off positions corresponding to the water level changes required to turn the pump or alarm on and off.

Table 7: Class 9036 Type FG30 Pedestal-Style Sump Pump Switch

	Pedestal-Style Sump Pump Switch		Accessory Kits	
				
Catalog Number	9036FG30		9049A60	9049A61
Description	2-pole, pedestal-style sump pump switch		Plastic center hole float	33.75 in. aluminum rod, 2 float stop assemblies, and attaching hardware
Quantity Required	1		1	1
NEMA Type	NEMA Type 1		—	—
Contact Action	Contacts close on liquid rise		—	—
Rod Length	—		—	33.75 in. (cannot be lengthened)
Voltage	120/240 Vac		—	—
Horsepower Rating	Single phase	2 hp @ 120 Vac	3 hp @ 240 Vac	—
	Polyphase	3 hp @ 120 Vac	5 hp @ 240 Vac	—



9036FG
9049A60
9049A61

Class 9037

Class 9037 closed tank float switches are used primarily on condensate pumps but may also be installed on closed industrial and diesel fuel day tanks. There are two types of Class 9037 float switches:

- Type E (flange mounted)
- Type H (with screw-in bushing)

Class 9037 Type E, Flange Mounted

Table 8 contains ordering information for Class 9037 Type E float switches. Order the rod and float accessory kits separately. Consult your local Square D field office when using Class 9037 float switches in liquids with a different specific gravity than water (1.0).

Table 8: Class 9037 Type E Float Switches

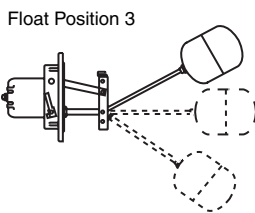
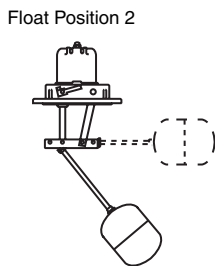
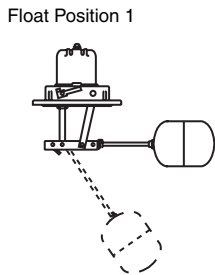

Specifications	
Application	Closed industrial tanks Flange mounted
Float movement	Transmitted through a quad ring seal, which may need occasional replacement
Tank Pressure	Up to 50 psi
Temperature	Ambient
	Media
Contact Operation	Determined by the float and rod mounting position
Float Travel	Determined by the post length



Catalog Numbers				
Post Length (L), in. (mm)	2.63 (67)		4.69 (119)	
Water Level Change	Minimum	Maximum	Minimum	Maximum
NEMA 1	9037EG8	9037EG9	9037EG10	9037EG13
NEMA 4	9037EW8	9037EW9	9037EW10	9037EW13
NEMA 7 and 9	9037ER8	9037ER9	9037ER10	9037ER13
Float Position	1	1, 2, 3	1	1, 2, 3
Float Kits				
Material	Catalog Number			
#304 Stainless Steel	9049EF1			
#316 Stainless Steel	9049EF2			

s For more information on float position, refer to pages 26–27.

For rod kit catalog numbers, refer to pages 26–27.

To receive all components packaged in a single carton, specify:

- Float switch Class, Type, and Form
- “R” and the rod number
- “F” and the float number

For example, to receive one each of 9037EG8, 9049ER1, and 9049EF1, specify **9037EG8R1F1**.

Figure 8: Type EG Dimensions

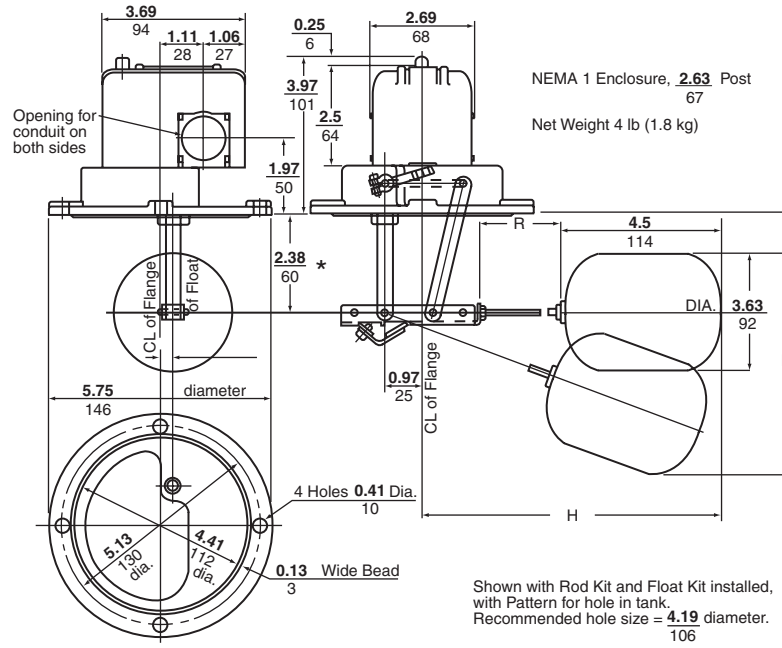

* Short length.

Figure 9: Type ER/EW Dimensions

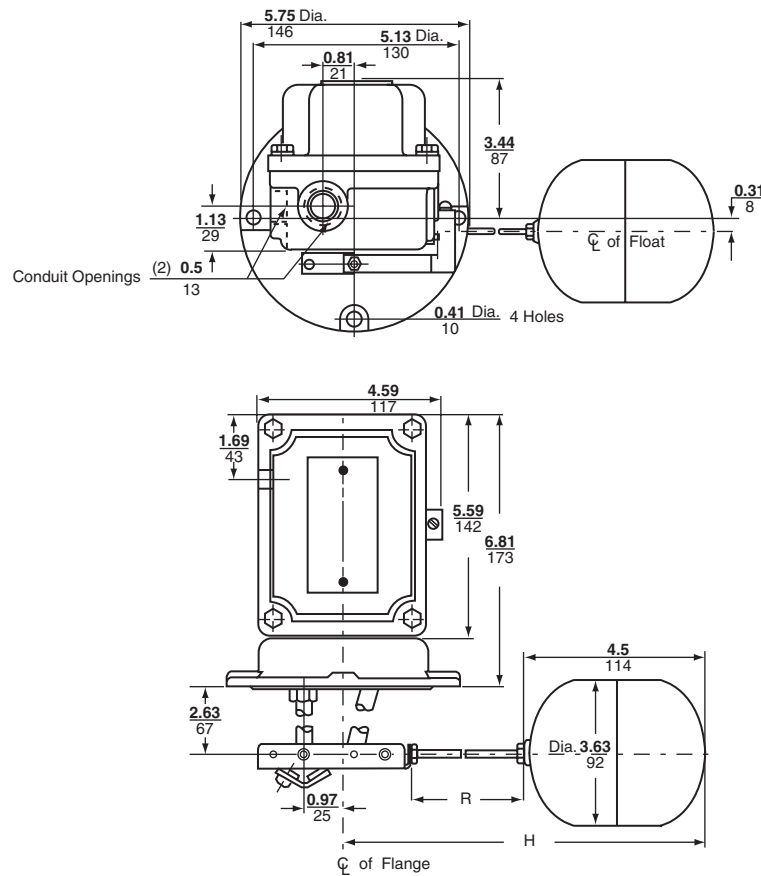

Position 1 Operation

In Position 1, the contacts **close** when the liquid rises. Select rod kits from Table 9.

Table 9: Class 9049 Rod Kits—Position 1 Operation (Contacts *Close* on Liquid Rise)

Catalog Numbers		Rod Kits						
Dimension in. (mm)	For Use on Float Switch Types	9049ER1	9049ER2	9049ER3	9049ER5	9049ER7	9049ER12	
R	EG8, EW8, ER8, EG10, EW10, ER10	1.75 (44)	2.5 (64)	3.25 (83)	5.25 (133)	7.25 (184)	12.25 (311)	
	EG9, EW9, ER9, EG13, EW13, ER13	1.75 (44)	2.5 (64)	3.25 (83)	5.25 (133)	7.25 (184)	12.25 (311)	
H	EG8, EW8, ER8, EG10, EW10, ER10	8.25 (210)	9 (229)	9.5 (241)	11.75 (298)	13.75 (349)	18.75 (476)	
	EG9, EW9, ER9, EG13, EW13, ER13	7.5 (191)	8.25 (210)	9 (229)	11 (279)	12 (305)	18 (457)	
A	Min.	EG8, EW8, ER8	1 (25)	1 (25)	1 (25)	1 (25)	1 (25)	1 (25)
		EG9, EW9, ER9	1 (25)	1 (25)	1 (25)	1 (25)	1 (25)	1 (25)
		EG10, EW10, ER10	3.06 (78)	3.06 (78)	3.06 (78)	3.06 (78)	3.06 (78)	3.06 (78)
		EG13, EW13, ER13	3.06 (78)	3.06 (78)	3.06 (78)	3.06 (78)	3.06 (78)	3.06 (78)
	Max.	EG8, EW8, ER8	2 (51)	2 (51)	2 (51)	2.5 (64)	3 (76)	4.25 (108)
		EG9, EW9, ER9	4 (102)	4.5 (114)	5 (127)	6 (152)	7.5 (191)	9.5 (241)
		EG10, EW10, ER10	4.06 (103)	4.06 (103)	4.06 (103)	4.56 (116)	5.06 (129)	6.31 (160)
		EG13, EW13, ER13	6.06 (154)	6.56 (167)	7.06 (179)	8.06 (205)	9.56 (243)	11.56 (294)
F	Min.	EG8, EW8, ER8, EG10, EW10, ER10	4.75 (121)	4.75 (121)	4.75 (121)	4.75 (121)	5 (127)	5.75 (146)
		EG9, EW9, ER9, EG13, EW13, ER13	6 (152)	6.25 (159)	6.25 (159)	6.5 (165)	6.5 (165)	9 (229)
	Max.	EG8, EW8, ER8, EG10, EW10, ER10	6 (152)	6.25 (159)	6.5 (165)	6.75 (171)	7.25 (184)	9 (229)
		EG9, EW9, ER9, EG13, EW13, ER13	9 (229)	9.75 (248)	10.25 (260)	11.5 (292)	13 (330)	17.5 (445)
Water Level Change	Min.	EG8, EW8, ER8, EG10, EW10, ER10	1.75 (44)	1.75 (44)	1.75 (44)	1.75 (44)	2 (51)	2.75 (70)
		EG9, EW9, ER9, EG13, EW13, ER13	3 (76)	3.25 (83)	3.25 (83)	3.5 (89)	3.5 (89)	6 (152)
	Max.	EG8, EW8, ER8, EG10, EW10, ER10	3 (76)	3.25 (83)	3.5 (89)	3.75 (95)	4.25 (108)	6 (152)
		EG9, EW9, ER9, EG13, EW13, ER13	6 (152)	6.75 (171)	7.25 (184)	8.5 (216)	10 (254)	14.5 (368)

Figure 10: Float Position 1

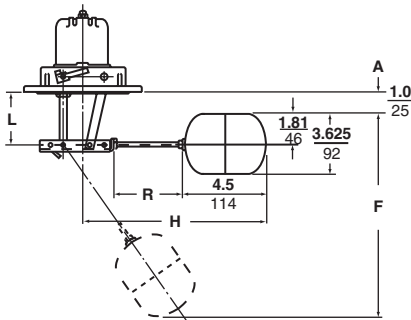

Figure 11: Float Position 2

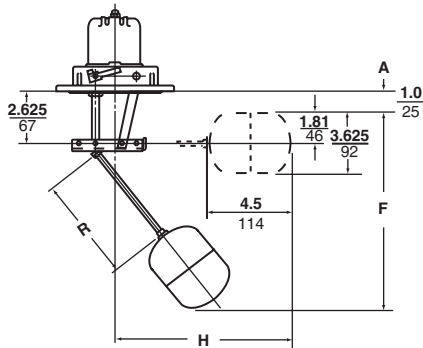
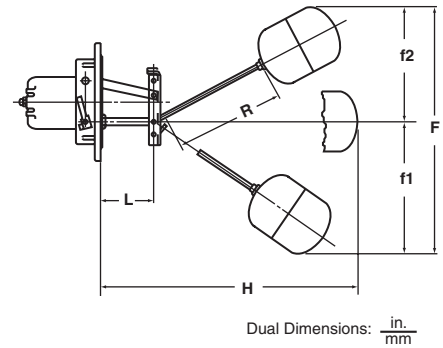

Figure 12: Float Position 3



Dual Dimensions: $\frac{\text{in.}}{\text{mm}}$

Position 2 Operation

In Position 2, the contacts **open** when the liquid rises. Select rod kits from Table 10.

Table 10: Class 9049 Rod Kits—Position 2 Operation (Contacts *Open* on Liquid Rise)

Catalog Numbers								
Dimension in. (mm)	For Use on Float Switch Types	Rod Kits						
		9049ER1	9049ER2	9049ER3	9049ER5	9049ER7	9049ER12	
R	EG9, EW9, ER9, EG13, EW13, ER13	1.75 (44)	2.50 (64)	3.25 (83)	5.25 (133)	7.25 (184)	12.25 (311)	
H	EG9, EW9, ER9, EG13, EW13, ER13	7.50 (191)	8.25 (210)	9.00 (229)	11.00 (279)	13.00 (330)	18.00 (457)	
A	Min.	EG9, EW9, ER9	1.00 (25)	1.00 (25)	1.00 (25)	1.00 (25)	1.00 (25)	
		EG13, EW13, ER13	3.06 (78)	3.06 (78)	3.06 (78)	3.06 (78)	3.06 (78)	
	Max.	EG9, EW9, ER9	3.00 (76)	3.50 (89)	4.00 (102)	5.00 (127)	6.00 (152)	8.50 (216)
		EG13, EW13, ER13	5.06 (129)	5.56 (141)	6.06 (154)	7.06 (179)	8.06 (205)	10.56 (268)
F	Min.	EG9, EW9, ER9, EG13, EW13, ER13	5.25 (133)	5.75 (146)	6.00 (152)	6.75 (171)	7.75 (197)	10.25 (260)
	Max.	EG9, EW9, ER9, EG13, EW13, ER13	7.25 (184)	8.25 (210)	9.00 (229)	10.75 (273)	12.75 (324)	17.75 (451)
Water Level Change	Min.	EG9, EW9, ER9, EG13, EW13, ER13	2.75 (70)	2.75 (70)	3.00 (76)	3.75 (95)	4.75 (121)	7.25 (184)
	Max.	EG9, EW9, ER9, EG13, EW13, ER13	4.25 (108)	5.25 (133)	6.00 (152)	7.75 (197)	9.00 (229)	12.25 (311)

Position 3 Operation

In Position 3, the contacts can be set to open (standard) or close (sump) on liquid rise by turning the control switch 180° around its horizontal center line. Select rod kits from Table 11.

Table 11: Class 9049 Rod Kits—Position 3 Operation (Contact Operation Adjustable)

Catalog Numbers								
Dimension in. (mm)	For Use on Float Switch Types	Rod Kits						
		9049ER1	9049ER2	9049ER3	9049ER5	9049ER7	9049ER12	
R	EG9, EW9, ER9, EG13, EW13, ER13	1.75 (44)	2.50 (64)	3.25 (83)	5.25 (133)	7.25 (184)	12.25 (311)	
H	EG9, EW9, ER9	9.00 (229)	9.75 (248)	10.50 (267)	12.50 (318)	14.50 (368)	19.50 (495)	
	EG13, EW13, ER13	11.00 (279)	11.75 (298)	12.50 (318)	14.50 (368)	16.50 (419)	21.50 (546)	
f1 or f2	Min.	EG9, EW9, ER9, EG13, EW13, ER13	2.75 (70)	2.75 (70)	3.00 (76)	3.50 (89)	3.75 (95)	4.50 (114)
	Max.	EG9, EW9, ER9, EG13, EW13, ER13	4.50 (114)	4.50 (114)	5.00 (127)	6.00 (152)	7.00 (178)	9.50 (241)
F	Min.	EG9, EW9, ER9, EG13, EW13, ER13	5.50 (140)	5.50 (140)	6.00 (152)	7.00 (178)	7.50 (191)	8.75 (222)
	Max.	EG9, EW9, ER9, EG13, EW13, ER13	9.00 (229)	9.00 (229)	10.00 (254)	12.00 (305)	14.00 (356)	19.00 (483)
Water Level Change	Min.	EG9, EW9, ER9, EG13, EW13, ER13	2.25 (57)	2.25 (57)	2.75 (70)	3.75 (95)	4.25 (108)	5.5 (140)
	Max.	EG9, EW9, ER9, EG13, EW13, ER13	5.75 (146)	5.75 (146)	6.75 (171)	8.75 (222)	10.75 (273)	15.75 (400)

Class 9037 Type H, with Screw-in Bushing



9037HG35
 Float on the Right

Table 12 contains ordering information for Class 9037 Type H float switches and factory installed modifications. Consult your local Square D field office when using float switches in liquids with a different specific gravity than water (1.0).

When ordering factory installed modifications, add the Form number to the end of the float switch catalog number. For example, to select a 9037HG36 switch with reverse action, order 9037HG36R.

Table 12: Class 9037 Type H Float Switches

Specifications										
Application	Condensate pumps A 2.5 in. cast-iron bushing attaches the float switch to the tank									
Float movement	Transmitted through a nitrile rubber seal such as a Buna-N quad ring. Occasional replacement may be necessary.									
Tank Pressure	Up to 50 psi									
Temperature	Ambient	up to 220 °F								
	Media	Buna-N seal: up to 215 °F. Viton seal: media up to 250 °F.								
Contact Operation	Close on liquid rise (standard) Open on liquid rise (Form R)									
Float Travel	Determined by the float rod angle. An external pointer indicates the float position.									
Materials (Standard)	#304 SS float, #316 SS rod, 2.5 in. cast iron bushing, brass sealing connector, Buna-N quad ring packing.									
Catalog Numbers										
Float Rod Angle	45°				90° offset					
Water Level Change Minimum–Maximum, in. (mm)	2.00–5.00 (52–127)		2.50–5.00 (64–127)		3.75–7.00 (95–178)		4.25–8.25 (108–210)		6.00–11.50 (152–292)	
Float Position ▲	Left	Right	Left	Right	Left	Right	Left	Right	Left	Right
NEMA Type 1	9037HG34	9037HG33	9037HG36	9037HG35	9037HG38	9037HG37	9037HG30	9037HG39	9037HG32	9037HG31
NEMA Type 4	9037HW34	9037HW33	9037HW36	9037HW35	9037HW38	9037HW37	9037HW30	9037HW39	9037HW32	9037HW31
NEMA Type 7 and 9	9037HR34	9037HR33	9037HR36	9037HR35	9037HR38	9037HR37	9037HR30	9037HR39	9037HR32	9037HR31
CL to CL, in. (mm)	—		3 (76)		4.25 (108)		5 (127)		7 (178)	
Modifications										Form
Omit 2.5 in. bushing										L1
Omit float										L2
Reverse action: contacts open on liquid rise										R ■
Viton packing, 5 oz float (diesel fuel, Types HG, HW, HR30, 31, 32, 37, 38, 39 only)										Z19
Viton packing, for media temperature up to 250 °F										Z20
Viton packing, #316 SS float										Z21

- ▲ Viewed from the front of the switch, facing the indicator scale.
- Type HG is field modifiable. Type HR and HW **cannot** be modified in the field.

For replacement floats, see “Class 9049 Accessories” on page 38.

Table 13 lists the float travel distances for the screw-in float switches. Refer to Figure 13.

Figure 13: Travel Dimensions

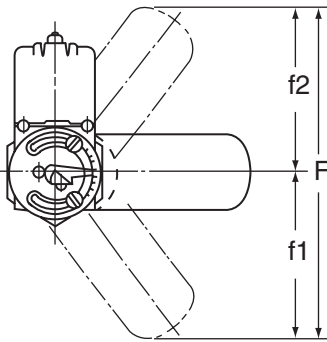

Table 13: Type H Float Travel Distances

Float Rod Angle	R in. (mm)	H ▲ in. (mm)	f1 in. (mm)		f2 in. (mm)		F in. (mm)	
			Minimum	Maximum	Minimum	Maximum	Minimum	Maximum
45°	—	6.22 (158)	2.25 (57)	4.50 (114)	2.00 (52)	4.50 (110)	4.25 (108)	9.00 (229)
90° offset	3.00 (76)	4.25 (108)	2.75 (70)	4.25 (108)	2.25 (57)	4.25 (108)	5.00 (127)	7.50 (191)
90° offset	4.25 (108)	5.50 (140)	3.50 (89)	5.50 (140)	2.75 (70)	4.00 (102)	6.25 (159)	9.50 (241)
90° offset	5.00 (127)	6.25 (159)	3.75 (95)	6.25 (159)	3.00 (76)	4.50 (110)	6.75 (171)	10.75 (273)
90° offset	7.00 (178)	8.25 (210)	4.75 (121)	8.25 (210)	3.75 (95)	5.75 (146)	8.50 (216)	14.00 (356)

▲ Clearance from centerline of hub to side of tank.

Figure 14: Type HG—45° Angle Dimensions

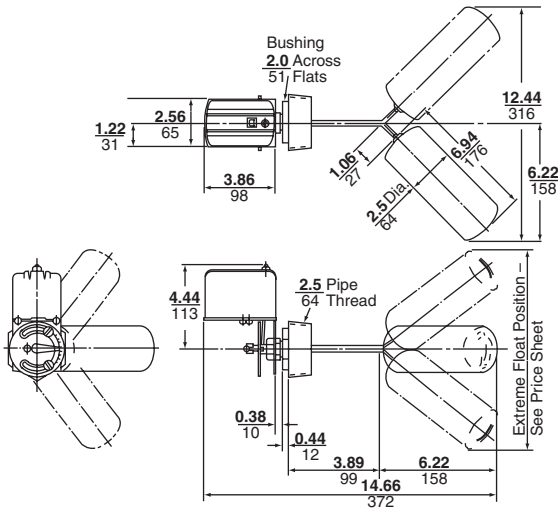

Figure 15: Type HG—90° Offset Dimensions

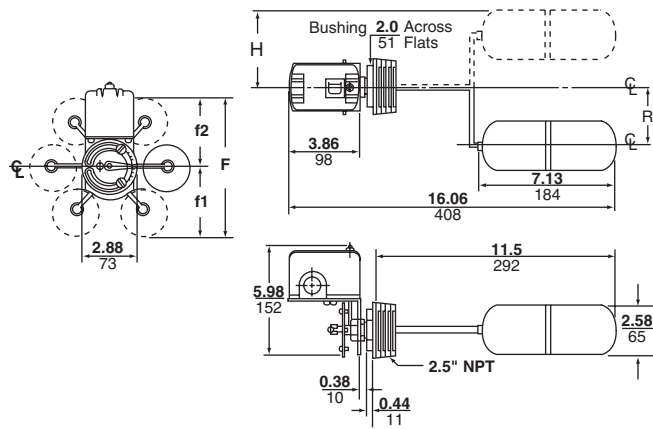

Figure 16: Type HR/HW—45° Angle Dimensions

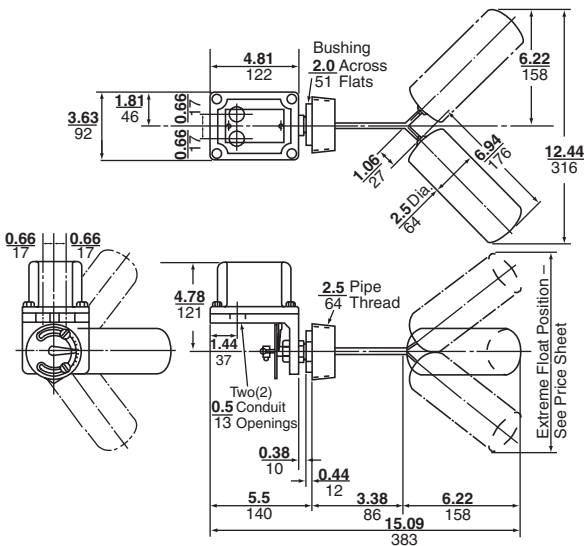
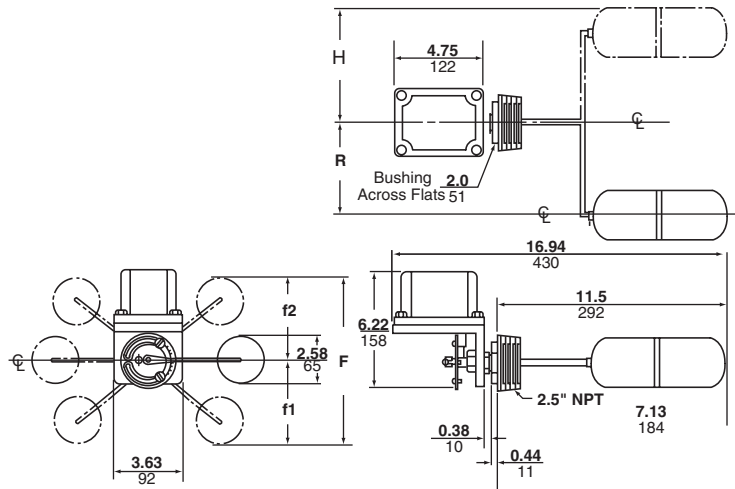

Figure 17: Type HR/HW—90° Offset Dimensions



Dual Dimensions: $\frac{\text{in.}}{\text{mm}}$

Class 9038

Class 9038 mechanical alternators provide a simple, positive means of mechanically alternating two pumps or motors. These alternators are used on devices that are installed in a duplex system with a common tank. There are three types of Class 9038 mechanical alternators:

- Type A (open tank and sump)
- Type C (with bushing)
- Type D (flange mounted, vertical)

When liquid level rises to the first level, one pump turns on. Both pumps automatically turn on when a peak condition occurs and the liquid level continues to rise. If Form N5 or N25 is present, and the water level continues to rise, a high water alarm is activated.

Mechanical alternators can be ordered with a manual transfer selector switch (Form N3), which allows the operator to select which pump cuts in first. The second pump only operates under peak demand conditions or if the first pump fails. When the switch is disengaged, the alternator reverts to normal operation. Another option (Form N4) allows the alternator to be used as a two-level non-alternating unit.

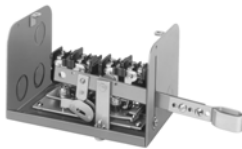

9038AG1

Class 9038 Type A, Open and Sump Tank Mechanical Alternators

Table 14 contains ordering information for Class 9038 Type A mechanical alternators, including factory installed modifications. Order float accessories separately. Consult your local Square D field office when using Class 9038 alternators in liquids with a different specific gravity than water (1.0).

When ordering a factory modification, add the Form number to the end of the mechanical alternator catalog number. For example, to select a 9038AG1 alternator with reverse action, order 9038AG1R.

Table 14: Class 9038 Type A Mechanical Alternators

Specifications	
Application	Open and sump tanks using duplex pumps
Float movement	Float operated
Ambient Temperature	-22 to +250 °F
Contact Operation	Close on liquid rise (standard) Open on liquid rise (Form R)
Catalog Numbers	
NEMA 1	9038AG1
NEMA 4 (compensating spring standard)	9038AW1
NEMA 7 and 9 (compensating spring standard)	9038AR1
Modifications	
Compensating spring (Type AG)	C
Manual transfer selector switch	N3
Two-level, non-alternating unit	N4
High water alarm circuit (single pole)	N5
High water alarm circuit (two pole)	N25
Reverse action: contacts open on liquid rise	R
Accessories	
Compensating spring (Type AG)	Catalog Number 9049A15

Table 15 lists the operating forces for Class 9038 Type A alternators. Use this table when selecting additional tubing or when selecting floats and rods for accessories made by other manufacturers.

Table 15: Class 9038 Type A Operating Forces

Catalog Number	9038AG1		9038AG1R		9038AR1/9038AW1	9038AR1R/9038AW1R	
	Minimum	Maximum	Minimum	Maximum	Standard	Standard	
Lever Length Position							
Force Up to Trip ▲ (oz), without Form C	18	16	14	11	—	—	
Force Down to Trip ▲ (oz), without Form C	20	17	16	12	—	—	
Maximum Rod Length Supported by the Compensating Spring ■ ft (m)	Brass	10 (3.05)	8 (2.44)	7 (2.13)	6 (1.83)	16 (4.88)	19 (5.79)
	Stainless Steel	12 (3.66)	10 (3.05)	8 (2.44)	7 (2.13)	20 (6.1)	23 (7.01)
	Aluminum	25 (7.62)	21 (6.4)	17 (5.18)	15 (4.57)	41 (12.5)	47 (14.33)
Maximum Weight of Tubing and Stops Supported by the Compensating Spring (oz)	47	41	33	30	74	85	

- ▲ Add 2 oz for high water alarm (Form N5 or N25).
- Rod length determined using Class 9049 rod material (0.38 in. / 10 mm O.D. tubing). Other types of rod must be weighed and compared to the “Weight of Tubing and Stops” row above.

Accessory Kits

Table 16 lists the Class 9049 accessory kits for Class 9038 Type A alternators. The accessories are ordered separately from the alternators. Order tapped-at-top floats for Type AG1 (except form C) and center-hole floats for Types AG1C, AW1, and AR1.

Table 16: Class 9049 Accessories for Class 9038 Type A Float Switches (weight in oz)

Accessory Kits Catalog Numbers	Tapped-at-Top Floats (#304 SS)			Center-Hole Floats (#304 SS)			Additional Tubing ▲		
	9049A6	9049A6A	9049A6S	9049A6C	9049A6CA	9049A6CS	9049T1	9049T1A	9049T1S
Tubing	5 ft brass	5 ft Al	5 ft SS	5 ft brass	5 ft Al	5 ft SS	2.5 ft brass	2.5 ft Al	2.5 ft SS
Net buoyancy in water, 7 in. float ■	60	60	60	70	70	70	—	—	—
Total weight of stops	3	3	3	6	6	6	—	—	—
Number of stops	2	2	2	4	4	4	—	—	—
Weight of 5 ft rod, included	18.5	6	16.9	18.5	6	16.9	—	—	—
Weight per ft of extra rod	—	—	—	—	—	—	3.7	1.2	3.4

- Net buoyancy calculated with float 80% submerged, allowing for a 20% operating margin. Buoyancy data calculated for use in water. Consult your local Square D field office for buoyancy data in media having specific gravity different than water (1.0).
- ▲ Additional tubing kits add on to the float accessory kits and include a connector. Maximum recommended tubing length for tapped-at-top float: 12.5 ft (3810 mm).

When ordering float accessories, first specify the desired accessory kit, then as a second item, give the catalog number and the quantity of the additional tubing kits required. For example, for a 9049A6C kit with 15 ft of tubing, specify:

- A. 9049A6C, quantity = 1 (includes 5 ft of tubing)
- B. 9049T1, quantity = 4 (2.5 ft of tubing each, for a total of 10 additional ft)

Figure 18: Type AG1 Dimensions

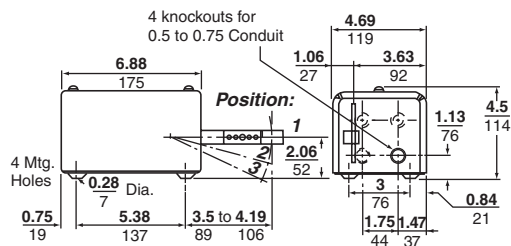
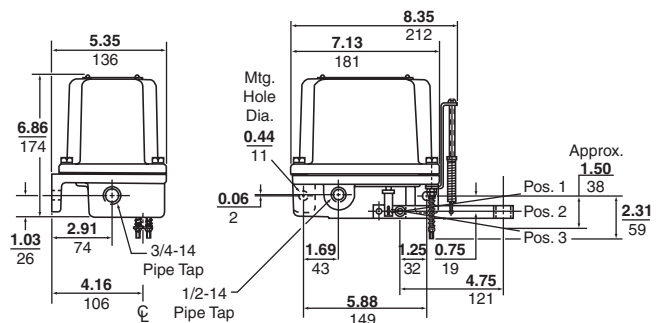

Figure 19: Type AR1/AW1 Dimensions



Class 9038 Type C, Closed Tank Mechanical Alternators with Bushing

Table 17 contains ordering information for Class 9038 Type C mechanical alternators. Consult your local Square D field office when using Class 9038 alternators in liquids with a different specific gravity than water (1.0).

When ordering a factory modification, add the Form number to the end of the alternator catalog number. For example, to select a 9038CG36 alternator with reverse action, select 9038CG36R.

Table 17: Class 9038 Type C Mechanical Alternators

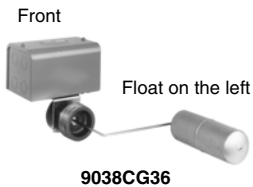

Specifications							
Application	Closed tanks using duplex, condensate pumps A 2.5 in. cast iron bushing attaches the float switch to the tank						
Float movement	Transmitted through a nitrile rubber seal such as a Buna-N quad ring. Occasional seal replacement may be necessary.						
Tank Pressure	Up to 50 psi						
Ambient Temperature	-22 to +250 °F						
Media Temperature (Minimum)	Solidification point of the medium in the tank, down to -22 °F						
Contact Operation	Close on liquid rise (standard) Open on liquid rise (Form R)						
Float Travel	Float travel is determined by the rod length. An external pointer indicates the float position. For more information on float travel and position, see "Float Travel" on page 35.						
Materials (Standard)	#304 SS float, #316 SS rod, 2.5 in. cast iron bushing, brass sealing connector, Buna-N quad ring packing						
Catalog Numbers							
Float Position ▲	Left			Right			
Water Level Change, Minimum–Maximum	in. (mm)	6.5–13 (165–330)	4–7.75 (102–197)	4.75–9.25 (121–235)	6.5–13 (165–330)	4–7.75 (102–197)	4.75–9.25 (121–235)
NEMA 1		9038CG32	9038CG34	9038CG36	9038CG31	9038CG33	9038CG35
NEMA 4		9038CW32	9038CW34	9038CW36	9038CW31	9038CW33	9038CW35
NEMA 7 and 9		9038CR32	9038CR34	9038CW36	9038CR31	9038CR33	9038CW35
Modifications					Form		
Omit 2.5 in. cast iron bushing					F3		
Omit float					L		
Manual transfer selector switch					N3		
Two-level, non-alternating unit					N4		
High water alarm circuit, single pole (Type CG only)					N5		
High water alarm circuit, two pole (Type CG only)					N25		
Reverse action: contacts open on liquid rise					R		
Fluorocarbon polymer such as Viton packing, 5 oz float (diesel fuel, Type CG only)					Z19		
Fluorocarbon polymer such as Viton packing, for media temperature up to 250 °F					Z20		
Fluorocarbon polymer such as Viton packing, #316 SS float					Z21		

▲ Viewed from front of alternator, facing indicator scale.

For replacement floats, refer to page 38.

Electromechanical Level Control Class 9038 Type C—Mechanical Alternators with Bushing

Table 18 lists the float travel distances for the screw-in float switches. Refer to Figure 20.

Table 18: Type C Float Travel Adjustments

R in. (mm)	A in. (mm)		B in. (mm)		C in. (mm)		D in. (mm)		F in. (mm)	
	Min.	Max.	Min.	Max.	Min.	Max.	Min.	Max.	Min.	Max.
4.25 (108) ▲	2 (51)	3.5 (89)	3.5 (89)	4.75 (121)	2.5 (64)	3.75 (95)	3.5 (89)	4.75 (121)	7 (178)	9.5 (241)
5 (127) ■	2.25 (57)	3.75 (95)	4 (102)	5.25 (133)	2.75 (70)	3 (76)	4 (102)	5.25 (133)	8 (203)	10.5 (267)
7 (178) ●	2.5 (64)	5 (127)	5 (127)	7 (178)	2 (51)	4 (102)	5 (152)	7 (178)	10 (254)	14 (495)

- ▲ CG33, CG34, CW33, CW34, CR33, CR34
- CG35, CG36, CW35, CW36, CR35, CR36
- CG31, CG32, CW31, CW32, CR31, CR32

Figure 20: Travel Dimensions

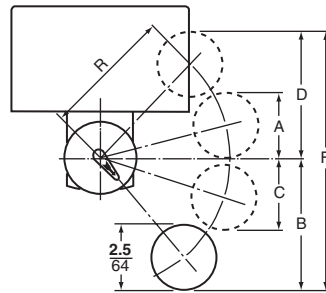

Figure 21: Type CG Dimensions

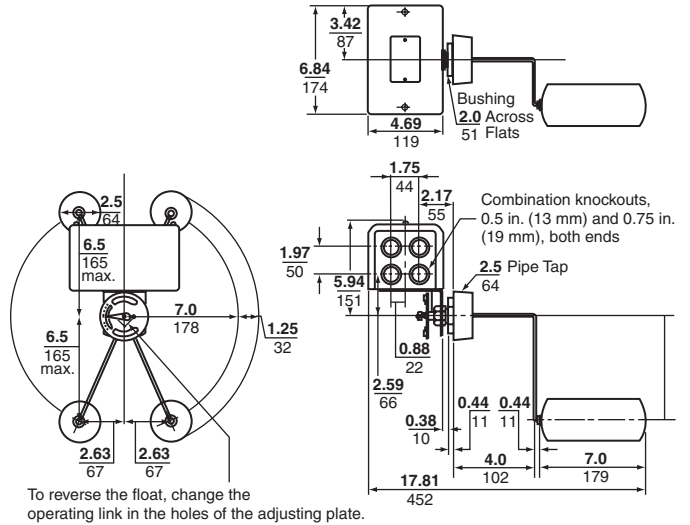
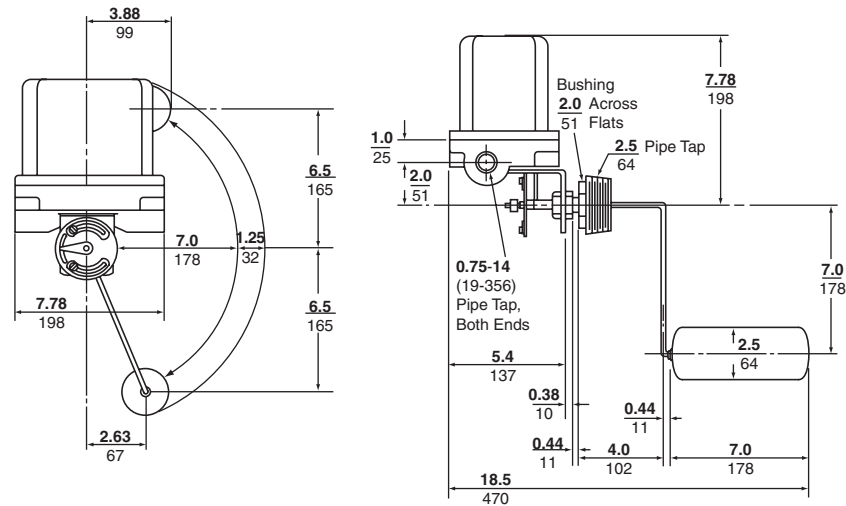

Figure 22: Type CR/CW Dimensions



Class 9038 Type D, Closed Tank Mechanical Alternators

Flange Mounted



9038DG
 9049ER5
 9049EF1

Table 19 contains ordering information for Class 9038 Type D alternators, factory modifications, and float kits. Order rod and float accessory kits separately. Consult your local Square D field office when using Class 9038 alternators in liquids with a different specific gravity than water (1.0).

When ordering a factory modification, add the Form number to the end of the alternator Type number. For example, to select a 9038DG7 alternator with manual transfer, order 9038DG7N3.

Table 19: Class 9038 Type D Mechanical Alternators

Specifications				
Application	Industrial closed tanks using duplex, condensate pumps Top or side mounted			
Float movement	Transmitted through a quad ring seal (occasional replacement may be necessary)			
Tank Pressure	Up to 50 psi			
Media Temperature	Viton seal: up to 250 °F			
Contact Operation	Close on liquid rise or open on liquid rise (field reversible)			
Float Travel	Determined by the length of the hinge post and rod and by the float position For more information on float travel and position, see "Float Travel" on page 35.			
Catalog Numbers				
Hinge Post Length (V), in. (mm)	2.63 (67)		4.69 (119)	
Water Level Change	Minimum	Maximum	Minimum	Maximum
NEMA 1	9038DG7	9038DG8	9038DG9	9038DG10
NEMA 4	9038DW7	9038DW8	9038DW9	9038DW10
NEMA 7 and 9	9038DR7	9038DR8	9038DR9	9038DR10
Modifications			Form	
Manual transfer selector switch			N3	
Two-level, non-alternating unit			N4	
High water alarm circuit (Type DG only)			N5	
Float Kits				
Material	Diameter in. (mm)	Length in. (mm)	Catalog Number	
#304 stainless steel	3.62 (92)	4.5 (114)	9049EF1	
#316 stainless steel	3.62 (92)	4.5 (114)	9049EF2	
The following float kits are available but are not recommended for use with 9038D mechanical alternators. The float travel dimensions shown in this catalog for 9038D devices do not apply when using these floats. A correction factor appears in the footnote of Tables 20–23 on pages 35–37.				
#304 stainless steel	2.5 (64)	7 (178)	9049HF3	
#316 stainless steel	2.5 (64)	7 (178)	9049HF4	

Float Travel

Float travel is determined by the length of the hinge post and rod and by the float position. The float may be operated in three different positions. In Position 1, the contacts close when the liquid rises. In the Position 2, the contacts open when the liquid rises. In Position 3, the contacts can be set to either open or close on liquid rise by turning the control switch 180° around its horizontal center line. Use Table 20 to select the appropriate rod kit when ordering Class 9038 Types DG7, DW7, or DR7 alternators.

Table 20: Class 9049 Rod Kits for Class 9038 Type DG7, DW7, and DR7 Alternators

Float Travel for Class 9038 Types DG7, DW7, and DR7 Alternators Minimum Water Level Change (V=2.63 in. / 67 mm)						
Dimensions in. (mm)	9049ER1	9049ER2	9049ER3	9049ER5	9049ER7	9049ER12
R	1.75 (44)	2.5 (64)	3.25 (83)	5.25 (133)	7.25 (184)	12.25 (311)
H ▲	8.25 (210)	9 (229)	9.5 (241)	11.75 (298)	13.75 (349)	18.75 (476)
A	Min.	0.75 (19)	0.63 (16)	0.5 (13)	0.13 (3)	0.38 (10)
	Max.	0.63 (16)	0.38 (10)	0.25 (6)	0.0 (0)	1.5 (38)
B	Min.	5 (127)	5.38 (137)	5.5 (140)	6.38 (162)	7 (178)
	Max.	5 (127)	5.25 (133)	5.5 (140)	6.25 (159)	8.75 (222)
C	Min.	4 (102)	4.25 (108)	4.38 (111)	5 (127)	5.5 (140)
	Max.	4.25 (108)	4.5 (114)	4.63 (118)	5.13 (130)	7.75 (197)
D	Min.	1.75 (44)	1.75 (44)	1.75 (44)	1.75 (44)	1.75 (44)
	Max.	1.5 (38)	1.38 (35)	1.25 (32)	1 (25)	0.63 (16)
F	Min.	6.75 (171)	7.13 (181)	7.25 (184)	8.13 (207)	8.75 (222)
	Max.	6.5 (165)	6.63 (168)	6.75 (171)	7.25 (184)	9.38 (238)
G	Min.	1 (25)	1 (25)	1 (25)	1 (25)	1 (25)
	Max.	1.5 (38)	1.5 (38)	1.5 (38)	1.75 (44)	2.5 (64)

▲ Add 2.5 in. (64 mm) to H when using HF3 or HF4 floats.

Figure 23: Travel Dimensions

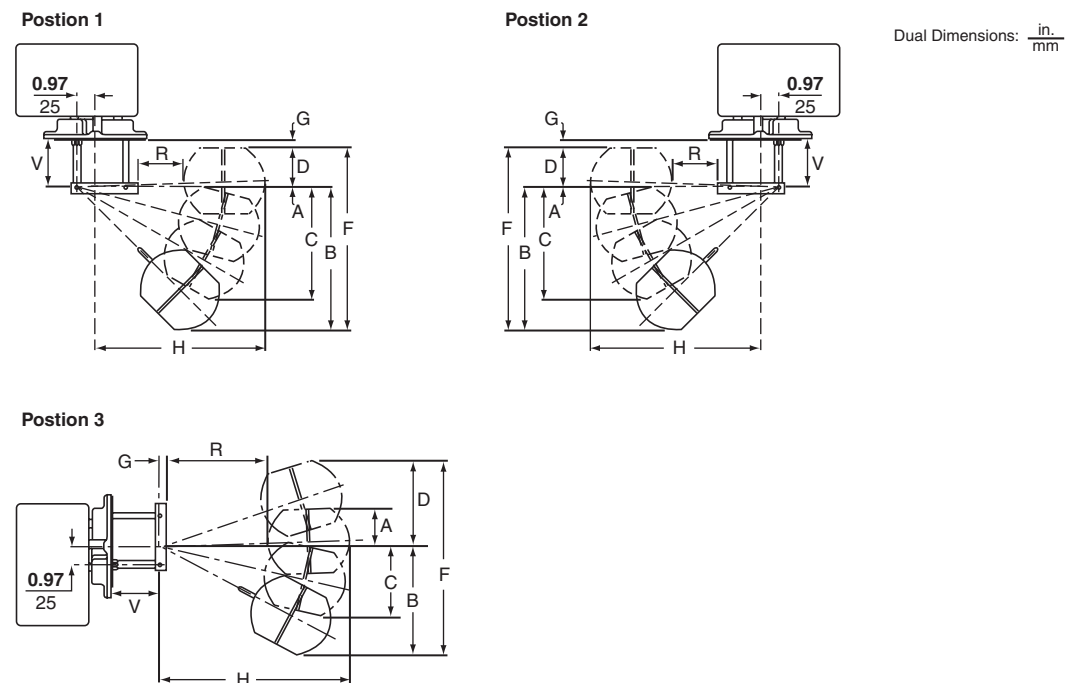

Use the following table to select the appropriate rod kit when ordering Class 9038 Types DG8, DW8, or DR8 alternators.

Table 21: Class 9049 Rod Kits for Use on Class 9038 Types DG8, DW8, and DR8 Alternators

Float Travel for Class 9038 Types DG8, DW8, and DR8 Alternators Minimum Water Level Change (V=2.63 in. / 67 mm)						
Dimensions in. (mm)	9049ER1	9049ER2	9049ER3	9049ER5	9049ER7	9049ER12
R	1.75 (44)	2.5 (64)	3.25 (83)	5.25 (133)	7.25 (184)	12.25 (311)
H ▲	7.5 (191)	8.25 (210)	9 (229)	11 (279)	13 (330)	18 (457)
A	Min.	0.0 (0)	0.5 (13)	1 (25)	2 (51)	3 (76)
	Max.	1.25 (32)	1.5 (38)	2 (51)	3 (76)	4 (102)
B	Min.	8 (203)	8.75 (222)	9.5 (241)	11.5 (292)	13.5 (343)
	Max.	6.5 (165)	7 (178)	7.75 (197)	9.5 (241)	11 (279)
C	Min.	6.5 (165)	7 (178)	7.5 (1910)	9 (229)	10.75 (273)
	Max.	6.5 (165)	7 (178)	7.5 (1910)	9 (229)	10.75 (273)
D ■	Min.	2 (51)	1.75 (44)	1.5 (38)	1.25 (32)	0.75 (19)
	Max.	0.5 (13)	0.25 (6)	0.0 (0)	0.75 (19)	1.75 (44)
F	Min.	10 (254)	10.5 (267)	11 (279)	12.75 (324)	14.25 (362)
	Max.	8.5 (216)	9 (229)	9.5 (241)	10.75 (273)	11.75 (298)
G	Min.	1.5 (38)	1.5 (38)	1.75 (44)	2 (51)	2 (51)
	Max.	2.5 (64)	2.75 (70)	3 (76)	3.75 (95)	4.5 (114)

▲ Add 2.5 in. (64 mm) to H when using HF3 or HF4 floats.

■ D is negative when the top of the float is below the horizontal centerline.

Use the following table to select the appropriate rod kit when ordering Class 9038 Types DG9, DW9, or DR9 alternators.

Table 22: Class 9049 Rod Kits for Class 9038 Type DG9, DW9, and DR9 Alternators

Float Travel for Class 9038 Types DG9, DW9, and DR9 Alternators Minimum Water Level Change (V=4.69 in. / 119 mm)						
Dimensions in. (mm)	9049ER1	9049ER2	9049ER3	9049ER5	9049ER7	9049ER12
R	1.75 (44)	2.5 (64)	3.25 (83)	5.25 (133)	7.25 (184)	12.25 (311)
H ▲	8.25 (210)	9 (229)	9.5 (241)	11.75 (298)	13.75 (349)	18.75 (476)
A	Min.	1 (25)	1 (25)	0.88 (22)	0.63 (16)	0.25 (6)
	Max.	0.5 (13)	0.13 (3)	0.0 (0)	0.88 (22)	1.63 (41)
B	Min.	5.25 (133)	5.75 (146)	6 (152)	7.25 (184)	8.25 (210)
	Max.	5.25 (133)	5.63 (143)	5.88 (149)	7.13 (181)	8.25 (210)
C	Min.	4.5 (114)	4.75 (121)	5 (127)	5.75 (146)	6.5 (165)
	Max.	4.5 (114)	4.75 (121)	5 (127)	5.88 (149)	6.75 (171)
D	Min.	2 (51)	2 (51)	2 (51)	2 (51)	1.88 (48)
	Max.	1.5 (38)	1.25 (32)	1.13 (29)	0.75 (19)	0.5 (13)
F	Min.	7.25 (184)	7.75 (197)	8 (203)	9.25 (235)	10.13 (257)
	Max.	6.75 (171)	6.88 (175)	7 (178)	7.88 (200)	8.75 (222)
G	Min.	3 (76)	3 (76)	3 (76)	3 (76)	3.25 (83)
	Max.	3.75 (95)	4 (102)	4 (102)	4.38 (111)	4.63 (117)

▲ Add 2.5 in. (64 mm) to H when using HF3 or HF4 floats

Electromechanical Level Control Class 9038 Type D—Flange Mounted Mechanical Alternators

Use the following table to select the appropriate rod kit when ordering Class 9038 Type DG10, DW10, or DR10 alternators.

Table 23: Class 9049 Rod Kits for Class 9038 Type DG10, DW10, and DR10 Alternators

Float Travel for Class 9038 Types DG10, DW10, and DR10 Alternators Minimum Water Level Change (V=4.69 in. / 119 mm)						
Dimensions in. (mm)	9049ER1	9049ER2	9049ER3	9049ER5	9049ER7	9049ER12
R	1.75 (44)	2.5 (64)	3.25 (83)	5.25 (133)	7.25 (184)	12.25 (311)
H ▲	7.5 (191)	8.25 (210)	9 (229)	11 (279)	13 (330)	18 (457)
A	Min.	0.5 (13)	1 (25)	1.5 (38)	2.5 (64)	3.25 (83)
	Max.	1.5 (38)	2 (51)	2.5 (64)	4 (102)	5.5 (140)
B	Min.	8 (203)	8.75 (222)	9.5 (241)	11.5 (292)	13.5 (343)
	Min.	7 (178)	7.75 (194)	8.25 (210)	10 (254)	11.5 (292)
C	Min.	1.75 (44)	1.75 (44)	1.5 (38)	1.25 (32)	1 (25)
	Max.	0.5 (13)	0.25 (6)	0.0 (0)	1 (25)	1.5 (38)
D	Min.	8.75 (222)	10.5 (267)	11 (279)	12.75 (324)	14.5 (368)
	Max.	8.5 (216)	9 (229)	9.5 (241)	10.5 (267)	12 (305)
F	Min.	3.25 (83)	3.5 (89)	3.5 (89)	3.75 (95)	4 (102)
	Max.	4.75 (121)	5 (127)	5.25 (133)	6 (152)	6.75 (171)
G	Min.	4.75 (121)	5 (127)	5.25 (133)	6 (152)	6.75 (171)
	Max.	4.75 (121)	5 (127)	5.25 (133)	6 (152)	6.75 (171)

- ▲ Add 2.5 in. (64 mm) to H when using HF3 or HF4 floats.
- D is negative when the top of the float is below the horizontal centerline.

Figure 24: Type DG Dimensions

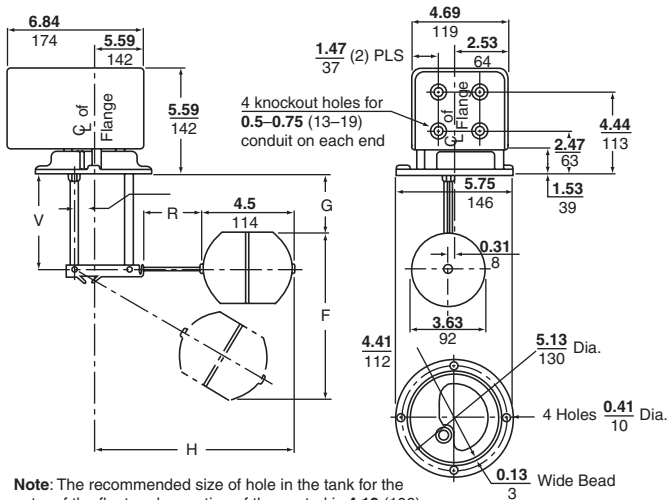

Note: The recommended size of hole in the tank for the entry of the float and mounting of the control is 4.19 (106). Floats shown are Type EF, 4.5 (114) long. Add 2.5 (64) to "H" if using Type HF Floats, which are 7.0 (178) long.

Figure 25: Type DR/DW Dimensions

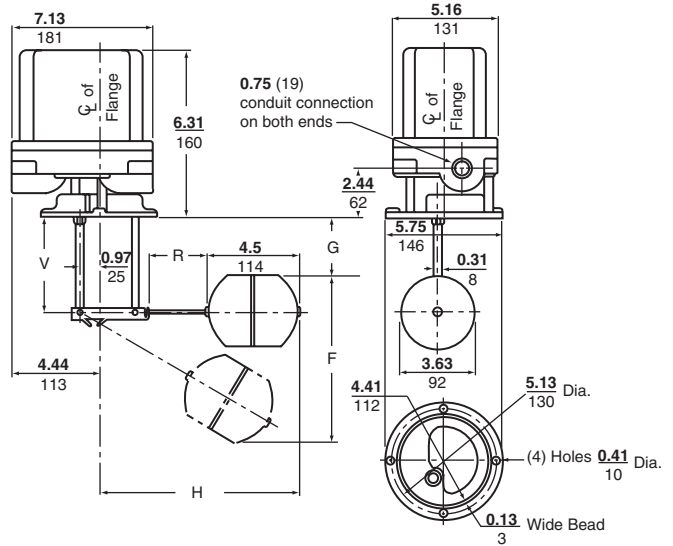

Accessories

Table 24: Class 9049 Accessories

Catalog Number	Description	Equipment To Be Serviced
9049A6	7 in. Tapped at Top #304 Stainless Steel Float, 5 ft Brass rod, 2 stops	All 9036, 9038A
9049A6A	7 in. Tapped at Top #304 Stainless Steel Float, 5 ft Aluminum rod, 2 stops	All 9036, 9038A
9049A6C	7 in. Center Hole #304 Stainless Steel Float, 5 ft Brass rod, 4 stops	All 9036, 9038A
9049A6CA	7 in. Center Hole #304 Stainless Steel Float, 5 ft Aluminum rod, 4 stops	All 9036, 9038A
9049A6CS	7 in. Center Hole #316 Stainless Steel Float, 5 ft Stainless Steel rod, 4 Stainless Steel stops	All 9036, 9038A
9049A6S	7 in. Tapped at top #316 Stainless Steel Float, 5 ft Stainless Steel rod, 2 Stainless Steel stops	All 9036, 9038A
9049AF1	7 in. Round Center Hole #304 Stainless Steel Replacement Float (<i>do not remove ballast</i>)	9049A6C, A6CA, DRA31
9049AF2	7 in. Round Center Hole #316 Stainless Steel Replacement Float (<i>do not remove ballast</i>)	9049A6CS, DRA32
9049AF3	7 in. Round Tapped at top #304 Stainless Steel Replacement Float (<i>do not remove ballast</i>)	9049A6, A6A, DCA1, DCA3
9049AF4	7 in. Round Tapped at top #316 Stainless Steel Replacement Float (<i>do not remove ballast</i>)	9049A6S, DCA2, DCA4
9049A13	Compensating Spring	9036GG
9049A15	Compensating Spring	9038AG
9049A19	Compensating Spring	9036DG
9049A20	Compensating Spring	9036DR, DW
9049A54	Mounting Bracket—Replacing obsolete 9036A with 9036G	9036GG
9049A55	Mounting Bracket—Replacing 9036A (S or F1) with 9036G	9036GG
9049A58	Form R lever	9036DG
9049EF1	#304 Stainless Steel Float (<i>do not remove ballast</i>)	9037E, 9038D
9049EF2	#316 Stainless Steel Float (<i>do not remove ballast</i>)	9037E, 9038D
9049ER1	1-3/4 in. Stainless Steel Rod	9037E, 9038D
9049ER2	2-1/2 in. Stainless Steel Rod	9037E, 9038D
9049ER3	3-1/4 in. Stainless Steel Rod	9037E, 9038D
9049ER5	5-1/4 in. Stainless Steel Rod	9037E, 9038D
9049ER7	7-1/4 in. Stainless Steel Rod	9037E, 9038D
9049ER12	12-1/4 in. Stainless Steel Rod	9037E, 9038D
9049GF1	#304 Stainless Steel Float (<i>do not remove ballast</i>)	9037G
9049GF2	#316 Stainless Steel Float (<i>do not remove ballast</i>)	9037G
9049HF3	#304 Stainless Steel Float (<i>do not remove ballast</i>)	9037H, 9038C, D ▲
9049HF4	#316 Stainless Steel Float (<i>do not remove ballast</i>)	9037H, 9038C, D ▲
9049T1	Additional Rod Kit: One 2-1/2 ft section of Brass rod, connector	9049A6, A6C
9049T1A	Additional Rod Kit: One 2-1/2 ft section of Aluminum rod, connector	9049A6A, A6CA
9049T1S	Additional Rod Kit: One 2-1/2 ft section of Stainless Steel rod, connector	9049A6S, A6CS
9049UMS1	Universal Mounting Bracket	All 9036; 9038AG, AR, AW

▲ Not recommended for 9038D mechanical alternators. 9049EF1 (#304 SS) and 9049EF2 (#316 SS) are recommended instead.

Renewal Parts Kits

Renewal parts are generally available for Pump Control products with a current date code or with a numerical date code (such as 172, which corresponds to the first quarter of 1972). Parts are no longer available for devices manufactured before 1965.

Table 25: Class 9998 Renewal Parts Kits for Class 9036–9038 Devices

Catalog Number	Description	Equipment To Be Serviced
9998A01	Replacement High-Level Alarm, Single-Pole Snap Switch, SPDT	Form N5
9998C03	Replacement High-Level Alarm, Double-Pole Snap Switch, DPDT	Form N25
9998PC213	Replacement Switch Mechanism	9036GR, GW, Series C (All Except Form H and R)
9998PC214	Replacement Switch Mechanism	9036GR, GW, Series C (Form R Only)
9998PC215	Replacement Switch Mechanism	9036GR, GW, Series C (Form H Only)
9998PC216	Cover Gasket	9036, 9037 GW Only
9998PC286	Replacement Switch Mechanism	9036DR1, DW1, Series B, Form C
9998PC287	Replacement Switch Mechanism	9036DR1, DW1, Series B, Form R
9998PC319	Replacement Switch Mechanism	9035DG11
9998PC334	Replacement Switch Mechanism	9035DR10, DW10, DR30, DW30
9998PC335	Replacement Switch Mechanism	9035DR11, DW11, DR31, DW31

Schneider Electric USA

8001 Knightdale Blvd.
Knightdale, NC 27545
1-888-Square D
1-888-778-2733
www.us.SquareD.com

9034CT9701R2/08 © 1998–2008 Schneider Electric All Rights Reserved
Replaces 9034CT9701 dated 5/1998

05/2008