

ICE MAKER INSTALLATION KIT

TO INSTALL SADDLE VALVE ON COPPER TUBE FOLLOW INSTRUCTIONS CAREFULLY

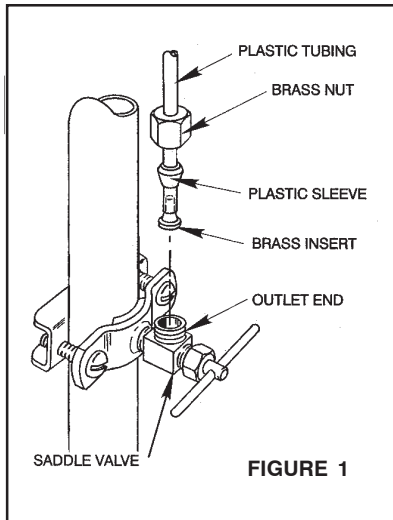
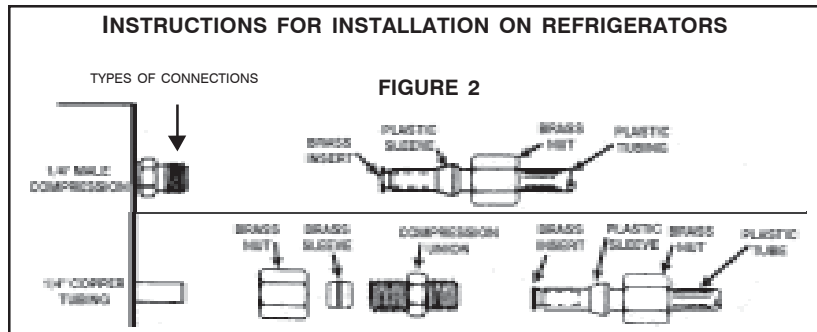

FIGURE 1

CAUTION: Do Not use plastic tubing in crawl spaces or behind walls. The tubing may become damaged and cause an undetected leak.

CAUTION: Do not turn handle before or while installing the Saddle Tapping Valve. Be sure the piercing lance does not protrude beyond the rubber gasket. Failure to do so may result in damage to the piercing needle.

1. Install the Saddle Tapping Valve on the cold water tubing so that the outlet is in a convenient direction.
A- For 3/8" O.D. Tubing use bracket with the side projections to prevent distortion of tubing.
B- Use the "V" side of bracket for all larger size tubing.
2. Tighten screws evenly. Brackets should be parallel. Tighten firmly- but do not overtighten.
3. Connect tubing to Saddle Tapping Valve outlet (Fig. 1).
4. Coil a minimum of 8 ft. (3 turns, 10" diameter) behind refrigerator. This will allow refrigerator to be moved away from the wall for cleaning or service.
5. Cut tubing to length required and make connection at refrigerator (Fig. 2).
6. Turn the Saddle Valve Handle clockwise until you feel it is firmly seated. Note: You now have pierced the copper tube and the valve is closed.



P/N 14702

ICE MAKER INSTALLATION KIT

TO INSTALL SADDLE VALVE ON COPPER TUBE FOLLOW INSTRUCTIONS CAREFULLY

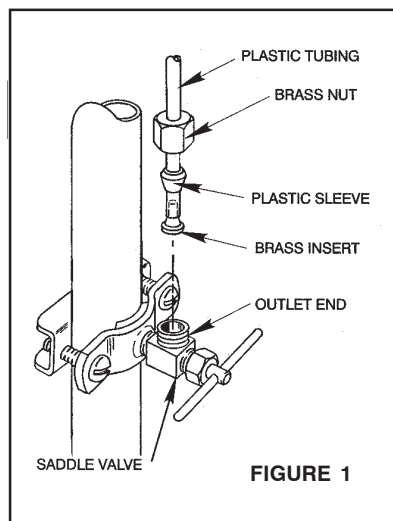
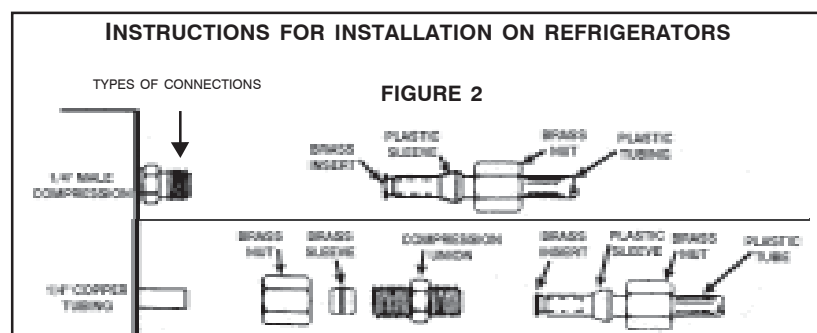

FIGURE 1

CAUTION: Do Not use plastic tubing in crawl spaces or behind walls. The tubing may become damaged and cause an undetected leak.

CAUTION: Do not turn handle before or while installing the Saddle Tapping Valve. Be sure the piercing lance does not protrude beyond the rubber gasket. Failure to do so may result in damage to the piercing needle.

1. Install the Saddle Tapping Valve on the cold water tubing so that the outlet is in a convenient direction.
A- For 3/8" O.D. Tubing use bracket with the side projections to prevent distortion of tubing.
B- Use the "V" side of bracket for all larger size tubing.
2. Tighten screws evenly. Brackets should be parallel. Tighten firmly- but do not overtighten.
3. Connect tubing to Saddle Tapping Valve outlet (Fig. 1).
4. Coil a minimum of 8 ft. (3 turns, 10" diameter) behind refrigerator. This will allow refrigerator to be moved away from the wall for cleaning or service.
5. Cut tubing to length required and make connection at refrigerator (Fig. 2).
6. Turn the Saddle Valve Handle clockwise until you feel it is firmly seated. Note: You now have pierced the copper tube and the valve is closed.



P/N 14702