

# CHECK 510T

## HORIZONTAL SWING – BRONZE

150 lb. SWP-300 lb. WOG† • Industrial Service  
Bronze Seat • Teflon Disc • Threaded Ends

### SPECIFICATIONS

510T	Conforms to: MSS SP-80, Type 4, Class 150, Threaded Ends.
------	--

### MATERIAL LIST

NO.	PART	MATERIAL	SPECIFICATION
1	Body	Bronze	ASTM B 62
2	Cap	Bronze	ASTM B 62
3	Lever	Brass	Commercial
4	Disc	Teflon	
5	Disc Holder	Brass	ASTM B 16 1/4" and 3/4" Incl.
		Bronze	ASTM B 62 1" to 2" Incl.
6	Pin	St. Steel	Commercial
7	Plug (not shown)	Brass	ASTM B 16
8	Retaining Ring	St. Steel	Commercial
9	Disc Nut	Brass	Commercial

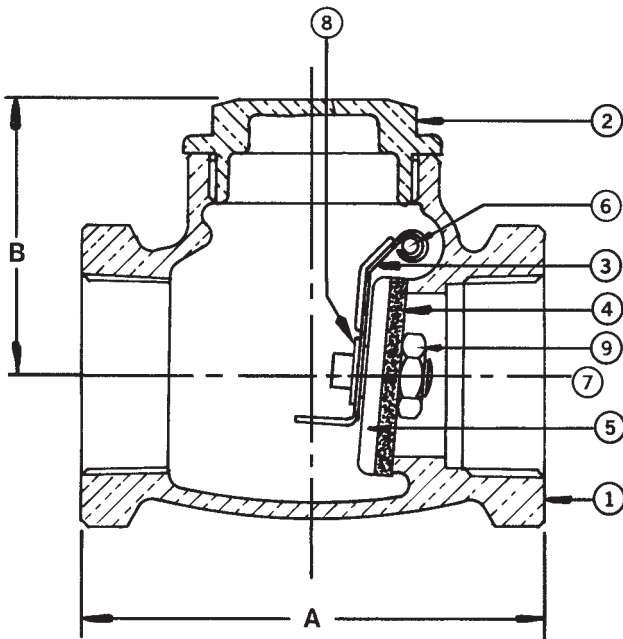

Note: Not intended for use in potable water.

DIMENSIONS - INCHES / MILLIMETERS				
UNITS	SIZE	A	B	C <sub>v</sub>
Inches	1/4	2.13	1.44	3.3
mm	6.4	54.0	36.5	
Inches	3/8	2.13	1.44	6.0
mm	9.5	54.0	36.5	
Inches	1/2	2.31	1.44	10.0
mm	12.7	58.8	36.5	
Inches	3/4	2.63	1.69	18.0
mm	19.5	66.7	42.9	
Inches	1	3.25	2.00	31.0
mm	25.4	82.6	50.8	
Inches	1 1/4	3.56	2.13	54.0
mm	31.8	90.5	54.0	
Inches	1 1/2	4.00	2.38	76.0
mm	38.1	101.6	60.3	
Inches	2	4.75	2.81	131.0
mm	50.8	130.2	208.0	

† Non-Shock

Rev. 6

**INNOVATION** IN EVERY VALVE



**MILWAUKEE VALVE**

The information presented on this sheet is correct at the time of publication. Milwaukee Valve reserves the right to change design, and/or material specifications without notice. For the Installation, Operation and Maintenance Manual (IOM) see the engineering section on our website. For the most current information access [www.milwaukeevalve.com](http://www.milwaukeevalve.com)

[www.milwaukeevalve.com](http://www.milwaukeevalve.com)