

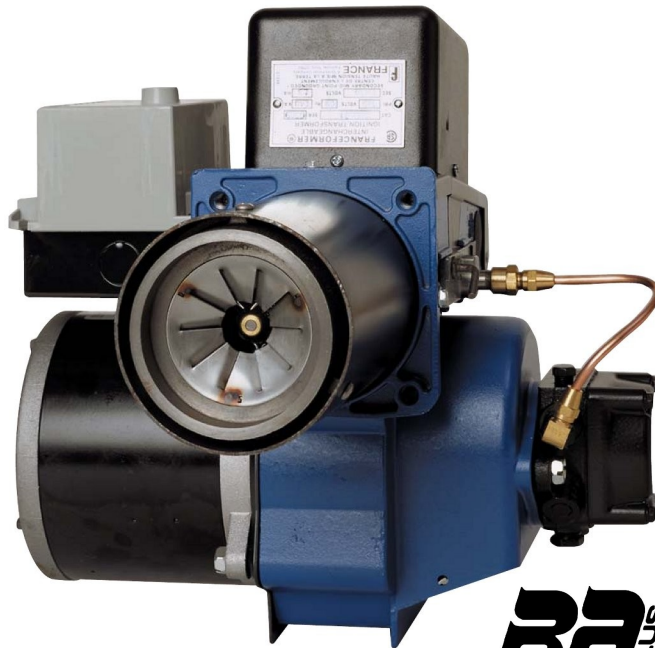

WAYNE COMBUSTION SYSTEMS
801 GLASGOW AVE.
FORT WAYNE, IN 46803

PHONE: (260) 425-9200
(800) 443-4625
FAX: (260) 424-0904

HS Oil Burner



Manual: 21663
Revision 15
Publication Date: 7/26/2011

Firing Capacity:

70,000 – 420,000 BTU/HR
0.50 – 3.00 GPH
(additional hardware required to fire above 2.50 GPH)

Electrical:

Power Supply.....115V / 60Hz / 1-Phase
Motor.....3450 RPM
Ignition.....10,000V / 23mA

Fuels:

No.1 or No.2 heating oil, diesel, B5, kerosene,
or JP8 Jet Fuel

Dimensions (Standard):

Height.....12 1/2"
Width.....12 7/8"
Depth.....7 3/4"
Center Line of Tube to Floor.....7"

INSTALLATION OF BURNER

INSTALLATION OF THE BURNER MUST BE DONE BY A QUALIFIED INSTALLER IN ACCORDANCE WITH REGULATIONS OF THE NATIONAL FIRE PROTECTION STANDARD FOR OIL-BURNING EQUIPMENT, NFPA NO. 31, AND IN COMPLETE ACCORDANCE WITH ALL LOCAL CODES AND AUTHORITIES HAVING JURISDICTION.

WARNING INCORRECT INSTALLATION, ADJUSTMENT, OR MISUSE OF THIS BURNER COULD RESULT IN DEATH, SEVERE PERSONAL INJURY, OR SUBSTANTIAL PROPERTY DAMAGE AND WILL VOID THE WARRANTY.

A QUALIFIED INSTALLER IS THE PERSON WHO IS RESPONSIBLE FOR THE INSTALLATION AND ADJUSTMENT OF THE EQUIPMENT AND WHO IS LICENSED TO INSTALL OIL-BURNING EQUIPMENT IN ACCORDANCE WITH ALL CODES AND ORDINANCES.

**THESE INSTRUCTIONS SHOULD BE AFFIXED TO THE BURNER
OR ADJACENT TO THE HEATING APPLIANCE.**

Burner / Appliance Service Log

Service Date	Contractor License #	Actions Performed
/ /		
/ /		
/ /		
/ /		
/ /		
/ /		
/ /		
/ /		
/ /		
/ /		
/ /		
/ /		
/ /		
/ /		
/ /		
/ /		
/ /		
/ /		
/ /		
/ /		
/ /		
/ /		
/ /		
/ /		
/ /		
/ /		
/ /		
/ /		
/ /		
/ /		
/ /		

Table of Contents

GENERAL INFORMATION

TO THE HOMEOWNER.....	1
HAZARD DEFINITIONS.....	1
GENERAL SPECIFICATIONS.....	1
APPROVALS.....	1

PREPARE INSTALLATION SITE

GENERAL INFORMATION.....	2
COMBUSTION CHAMBER.....	2
FUEL PUMPS.....	3
FUEL LINES.....	3
FUEL TANKS.....	3
AIR SUPPLY FOR COMBUSTION.....	3
CHIMNEY.....	3
DRAFT REGULATORS.....	3

PREPARE BURNER

GUN ASSEMBLY REMOVAL.....	4
NOZZLE INSTALLATION.....	4
CHECK AND ADJUST ELECTRODE SETTINGS.....	4
GUN ASSEMBLY INSTALLATION.....	5
CALIBRATE AIR CONE POSITION.....	6
WIRING.....	6

STARTING PROCEDURE

STARTING BURNER.....	7
FINAL ADJUSTMENTS.....	7
SETTING COMBUSTION EFFICIENCY.....	8
FINAL CHECKS.....	8

BURNER MAINTENANCE

SCHEDULED MAINTENANCE.....	9
BLOWER WHEEL REPLACEMENT.....	9
SUNTEC PUMP INSTALLATION INFORMATION.....	9
NOZZLE SELECTION.....	12
OIL PRIMARY SPECIFICATIONS.....	13
BURNER REPLACEMENT PARTS – MODEL HS.....	16
WAYNE® FUEL BLEND.....	17

MISCELLANEOUS

LIMITED WARRANTY.....	18
NOTES.....	19

GENERAL INFORMATION

TO THE HOMEOWNER

Since 1928, Wayne has supplied the Homeowners of the world with high quality oil burners. You are obtaining a superior burner unsurpassed in engineering design and product development. If properly installed and serviced, it will provide you with many years of efficient, trouble-free operation. Please read this manual carefully.

Wayne warrants its burner specifically to those who have purchased it for resale, including your dealer. If, in any case, you have a problem with your burner, or its installation, you should contact your dealer for assistance.

Wayne recommends yearly inspection/service of your oil heating system by a qualified service agency or individual.

A qualified service agency or individual must be:

- Licensed or certified to install and provide technical service to oil heating systems.
- Experienced with all applicable codes, standards and ordinances.
- Responsible for the correct installation and commission of the equipment.
- Skilled in the adjustment of oil burners using combustion test instruments.

⚠ DANGER **ELECTRIC SHOCK HAZARD**
High voltages are present in this equipment. Follow these rules to avoid electrical shock:

- Use only a properly grounded circuit. A ground fault interrupter is recommended.
- Do not spray water directly on burner.
- Turn off power before servicing.
- Read owner's manual before using

⚠ WARNING **OVERHEATING HAZARD**
Should overheating occur:

1. Shut off the manual oil valve to the appliance.
2. Do NOT shut off the control switch to the pump or blower.

⚠ DANGER **NEVER ATTEMPT TO USE GASOLINE AS A FUEL FOR THIS BURNER, AS IT IS MORE COMBUSTIBLE AND COULD RESULT IN A SERIOUS EXPLOSION.**

⚠ WARNING Incorrect installation, adjustment or use of the burner could result in severe personal injury death or substantial property damage from fire, carbon monoxide poisoning, soot or explosion.

⚠ CAUTION Do not store or use gasoline or other flammable vapors and liquids in the vicinity of this or any other appliance.

HAZARD DEFINITIONS

⚠ DANGER Indicates an imminently hazardous situation, which, if not avoided, will result in death, serious injury, or property damage.

⚠ WARNING Indicates a potentially hazardous situation, which, if not avoided, could result in death, severe personal injury, or substantial property damage.

⚠ CAUTION Indicates a potentially hazardous situation, which, if not avoided, may result in personal injury or property damage.

NOTICE Intended to bring special attention to information, but not related to personal injury or property damage.

GENERAL SPECIFICATIONS

Firing Rate:	0.50 – 3.00 GPH* 70,000 – 420,000 BTU/HR
Fuels:	No. 1 or No. 2 heating oil, diesel, B5, kerosene, or JP8 Jet Fuel ONLY - NEVER burn garbage or refuse in the unit - NEVER try to ignite oil by tossing burning material into the heating unit - NEVER burn waste or crankcase oil
Electrical:	<u>Power Supply</u> 115V / 60Hz / 1PH <u>Motor</u> 3450 RPM, N.E.M.A. Flange, Auto Overload Protection <u>Ignitor</u> 10,000V / 23mA secondary, Continuous Duty-Shielded Interrupted
Fuel Pump:	Suntec
Mounting:	Rigid Flange, Adjustable Flange, or Base Mount
Dimensions:	Height.....12 1/2" Width.....12 7/8" Depth.....7 3/4" Center Line of tube to Floor.....7"

* To fire over 2.50 GPH, additional hardware is required. See "Burner Replacement Parts" for details

APPROVALS

This burner complies with ANSI/UL Standard 296 and is for use with, No. 1 fuel oil, No. 2 fuel oil, or B5 blend. State and local approvals are shown on burner rating label. All burners should be installed in accordance with the National Fire Protection Association, and in complete accordance with all local codes and authorities having jurisdiction. Regulation of these authorities takes precedence over the general instructions provided in this manual.

PREPARE INSTALLATION SITE

GENERAL INFORMATION

When installing the appliance and/or burner, be sure to provide adequate space for easy service and maintenance.

Prior to installation of the oil burner, the heating system should be carefully inspected for defects and cleanliness. The flue passages and heat absorbing surfaces must be clean to ensure maximum heat transfer. Soot acts as an insulator, which retards the transfer of heat.

The combustion chamber, flue gas passages, and all doors and openings must be tightly sealed to eliminate air infiltration. Excess air decreases CO₂ levels and thus lowers efficiency. Inspect the flue and chimney for leaks and obstructions.

Be sure the chimney is of adequate size and height. Install a draft regulator the same size as the flue pipe (see page 3 under Chimneys and Draft Regulators).

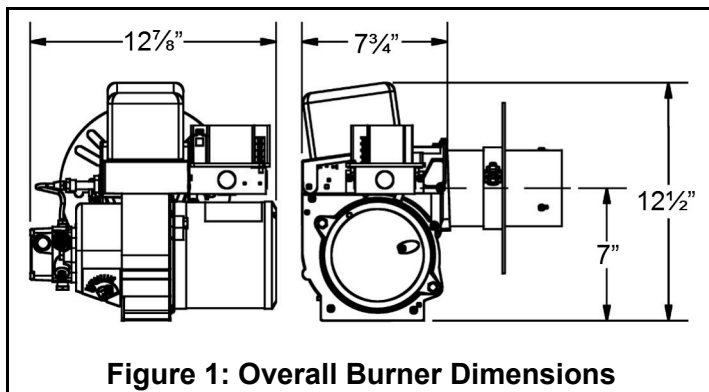

Figure 1: Overall Burner Dimensions

COMBUSTION CHAMBER

The purpose of a combustion chamber is to maintain a high flame temperature by reflecting the heat back into the flame. A high temperature ensures greater combustion efficiency and lower stack losses. An insulating refractory or a Fiber Fax type chamber can be used with this burner.

CAUTION Caution should be taken when installing Flamelock™ burners in stainless steel combustion chambers, because of the higher temperature levels produced by high performance flame retention burners. The temperature may exceed the temperature ratings of the stainless steel chamber and can result in chamber burnouts.

It is important to select and install, if necessary, the correct size chamber on a conversion job. (Suggested chamber dimensions are shown in Table 1.) On the Flamelock™ conversion burners, the atomized oil burns just off the Flamelock™ cone. On all oil burners, the atomized oil must not touch the sides or bottom of chamber, or smoke will result (see Figure 21, page 13). Install the burner so the face of the air cone of burner is set 1/4" behind the inside face of the chamber (See Figure 2).

To eliminate the smoke, excess air will be required, resulting in high stack temperature and lower combustion efficiency.

When you are replacing a standard burner with a flame retention burner, take the following precautions:

1. Use pliable ceramic liner to line the inside of chamber.
2. Adjust burner (see "Final Adjustments" on page 7).

Table 1: Suggested Combustion Chamber Dimensions

Conversion or Upgrading Chamber Dimensions (in inches)				
Firing Rate (GPH)	Square Chamber	Diameter Round Chamber	Height	Nozzle to Floor
0.50	7 x 7	8	11	5 – 6
0.75	8 x 8	9	12	5 – 6
0.85	8½ x 8½	9	12	5 – 6
1.00	9 x 9	10⅞	12½	5 – 6
1.25	10 x 10	11¼	12½	5 – 6
1.35	10½ x 10½	11¼	12¾	5 – 6
1.50	11 x 11	12⅜	13	5 – 6
1.65	11½ x 11½	13	13¾	5 – 6
2.00	12⅝ x 12⅝	14¼	13¾	6 – 7
2.50	14¼ x 14¼	16	14	7 – 8
3.00	15½ x 15½	17½	15	7 – 8

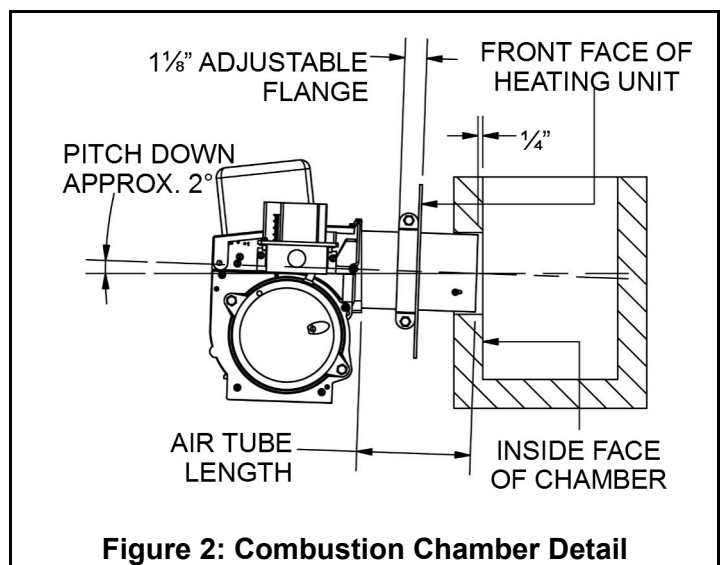

Figure 2: Combustion Chamber Detail

The "Air Tube Length" is the distance from the front of the aluminum fan housing to the face of the Air Cone.

NOTICE The maximum insertion depth of any given air tube is reduced by the thickness of the adjustable flange. Example: A 6" air tube can only be inserted about 5".

FUEL PUMPS

The Model HS oil burner is provided with single stage 3450 RPM fuel pump for a single pipe installation. This is satisfactory where the fuel supply is on the same level, or above burner, permitting gravity flow of oil.

CAUTION Never exceed 3 PSI to the suction side of the fuel pump. A pressure over 3 PSI may cause damage to the shaft seal and allow it to leak oil.

When it is necessary to lift the oil to the burner, a return line should be run between fuel pump and oil supply. (If lift exceeds a height of 10 feet, a two-stage fuel pump must be used with a return line.) When a two-line installation is made, a bypass plug must be installed on the Suntec pump. This is supplied with the burner, attached to the fuel pump, along with a pump information data sheet in a plastic bag.

FUEL LINES

When oil lines are continuous runs, heavy wall copper tubing is recommended. Avoid running oil lines overhead, against the appliance, or across ceiling or floor joists; if possible, install under the floor. Specific information on piping, connections, lift capabilities and tank installations is provided in the instruction sheet of the fuel pump manufacturer.

Be sure that all connections are completely airtight. Check all connections and joints. Flared fittings are recommended. Do not use compression fittings. Avoid using fittings in inaccessible locations.

Install shutoff valve in oil supply line in accessible locations, one close to the tank, another close to the oil burner but ahead of the filter.

Use an oil filter of adequate size on all installations. Install the filter inside the building between the tank shutoff valve and the burner.

NOTICE If the maximum burner firing rate exceeds the integral fuel pump strainer rating, an external U/L listed filter/strainer must be placed in the fuel line between the fuel tank and burner fuel pump.

FUEL TANKS

Local codes and regulations must be followed regarding tank and burner installation. Check existing tanks for water and sludge accumulation, clean if necessary. Also clean or replace existing piping.

AIR SUPPLY FOR COMBUSTION

A burner shall not be installed in an area where facilities for normal air circulation or infiltration are so limited as to interfere with ready obtainment of all air necessary for proper combustion and venting.

When the heating appliance is installed in a confined space, two permanent openings shall be provided: one near the top of the enclosure and one near the bottom. Each opening shall have a free area of not less than one square inch per 1000 BTU per hour (140 square inches per GPH) of the total input rating of all the appliances in the enclosure.

If the house is of unusually tight construction, has a kitchen ventilating system, exhaust fans, clothes dryer or vented fireplaces, it is recommended that combustion air be supplied through two permanent openings. The openings shall communicate directly, or by means of ducts, with the outdoors or to such spaces (attic or craw) that freely communicate with outdoors. For additional information, refer to ANSI standard NFPA 31.

CHIMNEY

Follow the recommendations of the appliance manufacturer. A chimney shall be capable of producing a draft as required by the appliance and as recommended by the appliance manufacturer. It must be properly designed, of adequate size, and should be above the surrounding objects, tile-lined, with no obstructions, and be in good state of repair. The smoke pipe should set flush with the inside of tile and be cemented in place. All cleanout doors should be sealed. A draft inducer may be used to overcome inadequate draft conditions. If a draft inducer is used, provisions must be made to insure the burner does not operate if the draft inducer fails.

DRAFT REGULATORS

A draft regulator shall be provided unless otherwise specified by the appliance manufacturer. The draft regulator shall be installed in accordance with local codes and regulations or in the absence of local codes, with the American National Standard NFPA31. Refer to appliance manufacturer's instructions for recommended over-fire and stack draft.

PREPARE BURNER

GUN ASSEMBLY REMOVAL

1. Remove the two cover plate screws holding the top cover in place and swing the transformer/cover open.
2. Disconnect the oil line fitting.
3. Remove the adjustment screw securing the gun assembly in the burner. DO NOT loosen or remove the screw securing the stop bracket in position.
4. Gently lift up and pull back on the gun; do not force it. It may be necessary to rotate the gun assembly 90° to help with it's removal.

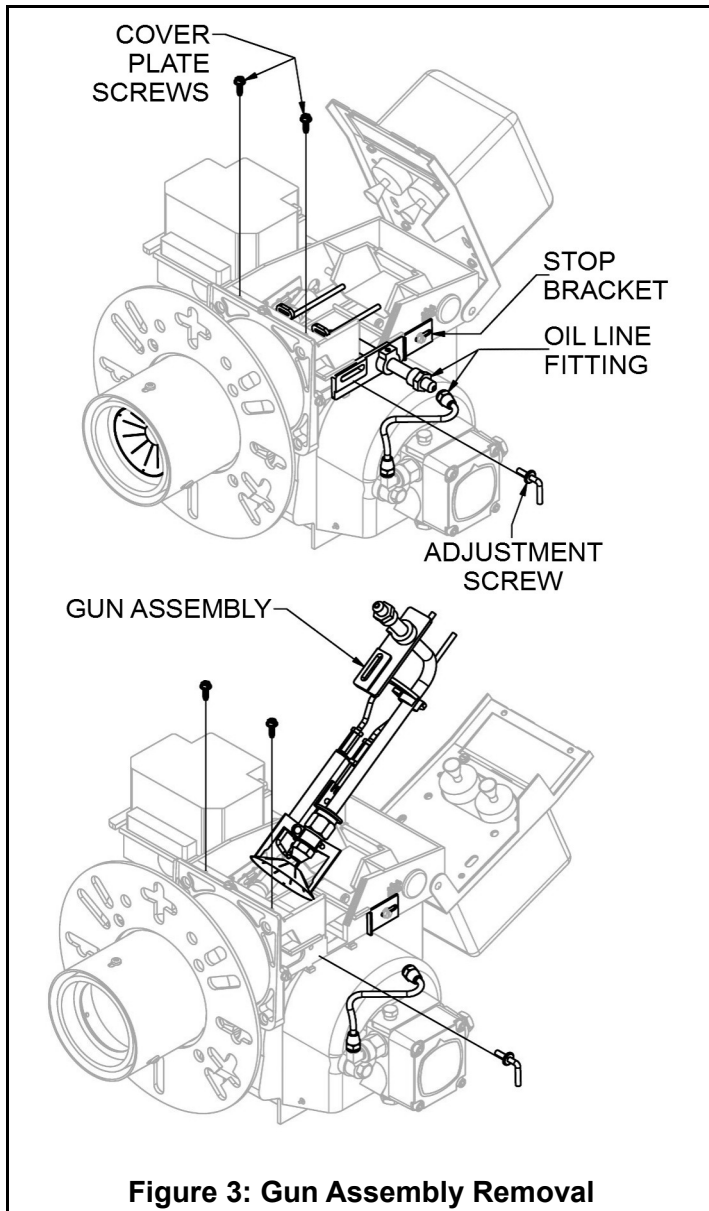

Figure 3: Gun Assembly Removal

NOZZLE INSTALLATION

To install a nozzle:

1. Remove the gun assembly and loosen the clamping screw (See Figure 4) on the flame retention assembly and slide the assembly off the adapter.
2. Inspect adapter face. Replace if nicked or scratched.
3. Install and tighten the nozzle in the adapter.

NOTICE

Do not touch the nozzle face or hold the nozzle by its integral filter as spray characteristics and flow may be affected. Be careful not to damage the electrode insulators or bend the electrodes.

4. Replace the flame retention assembly on the nozzle adapter. Make sure the clamp is tight against the shoulder on the adapter, and tighten the clamping screw.
5. Check the electrode setting.

NOTICE

For information on selecting the proper nozzle, see "Nozzle Selection" on page 12.

CHECK AND ADJUST ELECTRODE SETTINGS

The electrodes must be precisely spaced from the face of the nozzle as shown in the following figure:

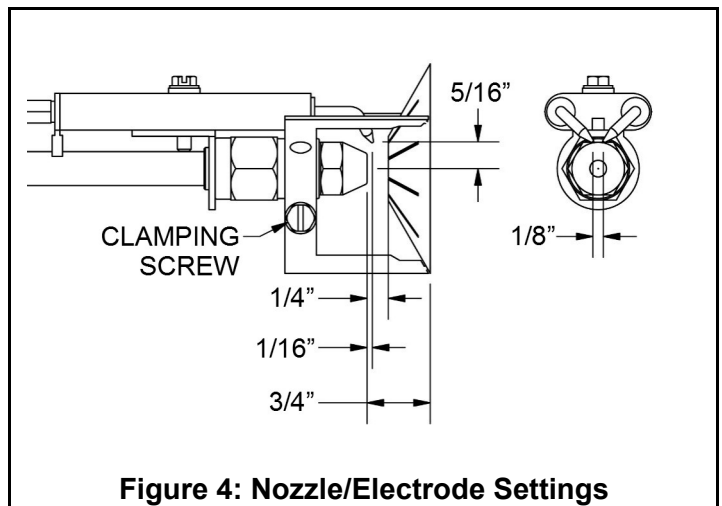

Figure 4: Nozzle/Electrode Settings

1. To check the height of the electrodes and the distance from the nozzle face the electrode tips, place the gauge in the end of the burner nozzle as shown in Figure 5.

NOTICE

In this orientation, the point at which the ruled scale on the side of the gauge (P/N: 14200-002) crosses the edge of the air cone corresponds to the Flamelock™ setting.

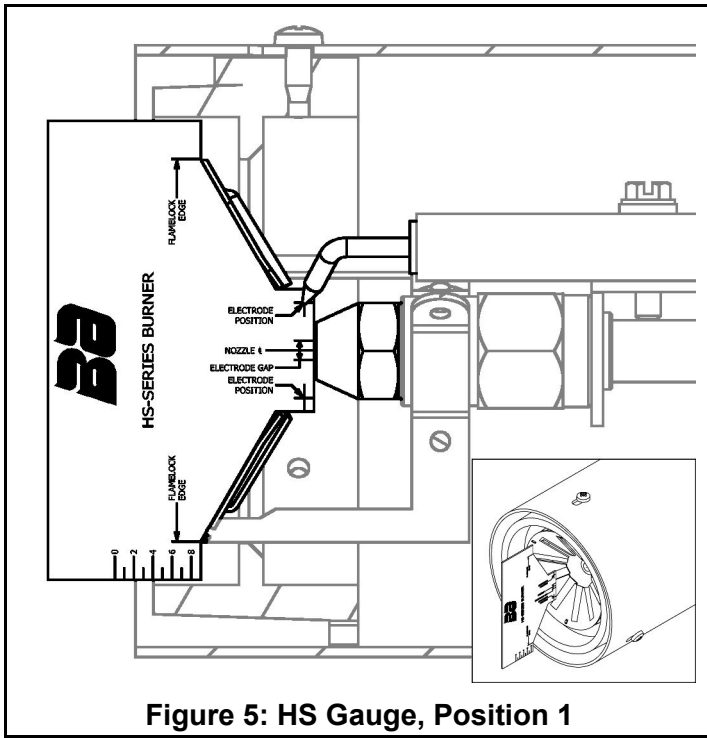

Figure 5: HS Gauge, Position 1

2. To check the spacing between the electrode tips, rotate the gauge 90° and place the gauge against the burner nozzle as shown in Figure 6.

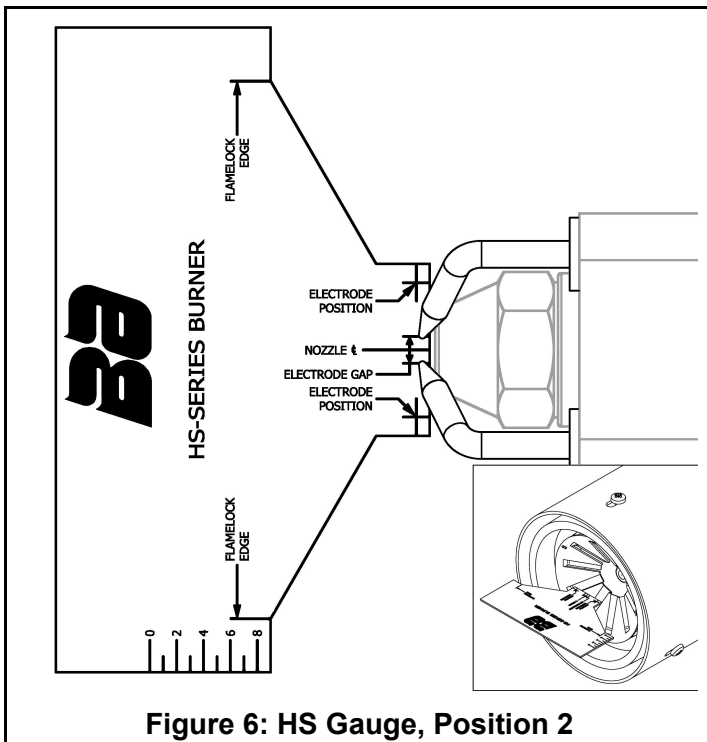

Figure 6: HS Gauge, Position 2

3. To adjust the spacing of the electrodes, slightly loosen the electrode clamping screw and move the electrodes to their correct position.

GUN ASSEMBLY INSTALLATION

1. Slide the assembly into the air tube; do not force it. The gun assembly must be lifted and guided through the air cone at the end of the tube. Start with the end of the oil pipe at the 12 o'clock position, slide the gun forward until the Flamelock™ is located in the air cone, then rotate it counterclockwise and position the side cover between the guide rails.
2. Pull the side bracket firmly back against the stop bracket.
3. Reinstall and tighten the adjustment screw.
4. Reconnect the oil line fitting.
5. Close the transformer/cover so that the springs contact the buss bars (Figure 7) and secure with the two mounting screws.

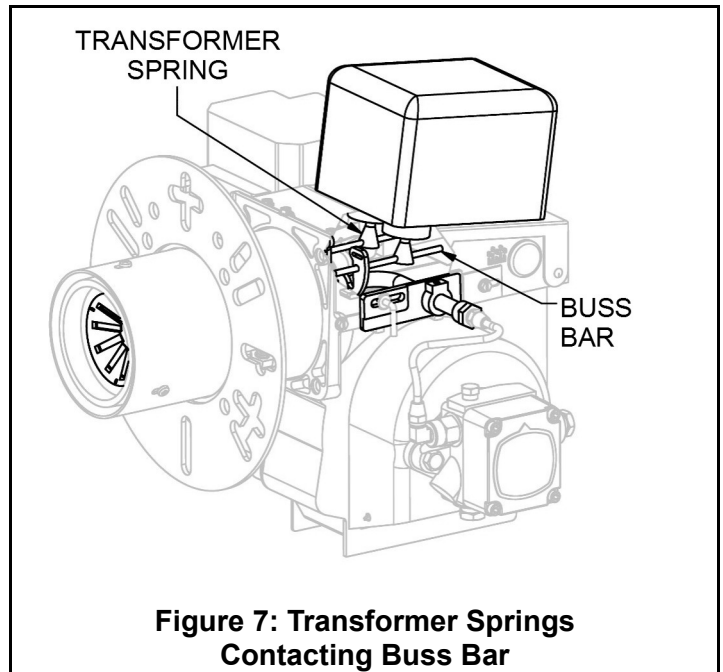

Figure 7: Transformer Springs Contacting Buss Bar

CAUTION Care should be taken when closing the transformer not to pinch the lead wires between the housing and cover plate.

CALIBRATE AIR CONE POSITION

If any components have been replaced on a given gun assembly, it may be necessary to calibrate the air cone position. As long as the stop bracket is not loosened or removed, this procedure is not necessary during normal maintenance.

1. Loosen the stop bracket, pull it back to the zero position, and re-tighten the bracket as indicated in Figure 8.

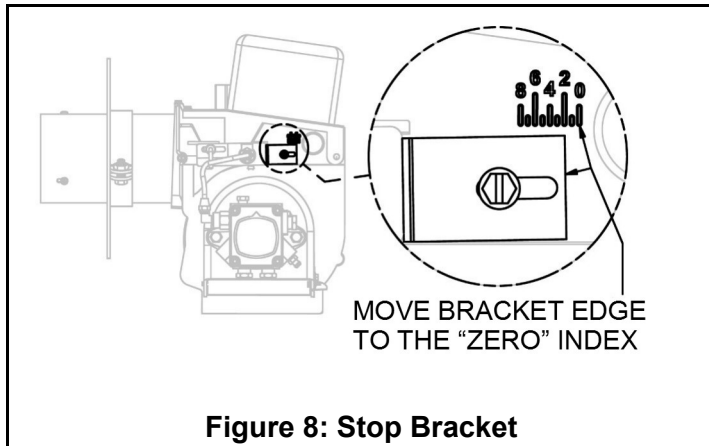

Figure 8: Stop Bracket

2. Loosen the gun adjustment screw, slide the gun assembly back until it is flat against the stop bracket, and re-tighten the adjustment screw.
3. At this point, the Flamelock™ cone should be flush with the stepped face of the air cone (See Figure 13, page 7). If it is not flush, loosen the 3 screws securing the air cone in place.

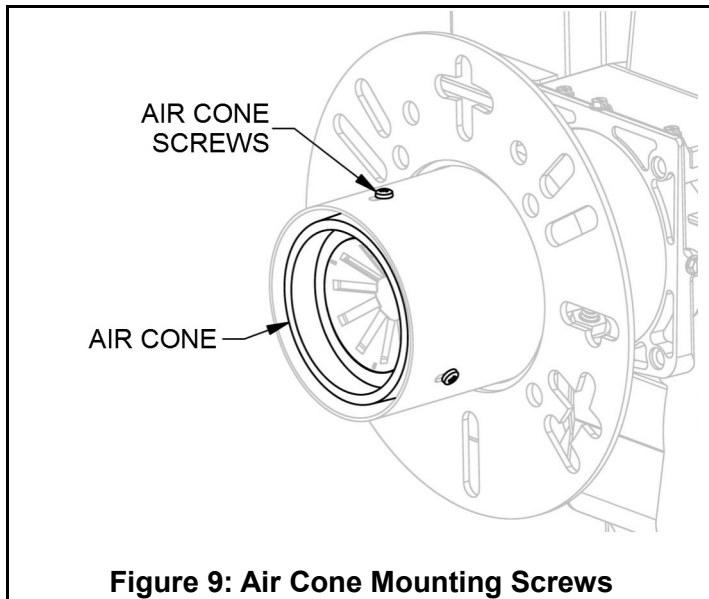

Figure 9: Air Cone Mounting Screws

4. Adjust the air cone to be flush with the Flamelock™ cone and tighten the 3 air cone screws.
5. After completing this calibration, it will be necessary to re-tune burner and check combustion.

WIRING

All wiring must comply with the National Electric Code and local ordinances. Refer to diagram supplied with burner or controls, making sure the burner and controls are wired correctly and that the line switch is properly connected to a 20 amp fused service.

NOTICE

To use with line voltage thermostat, jumper terminals T-T and add thermostat as shown at (1) in series with limit control.

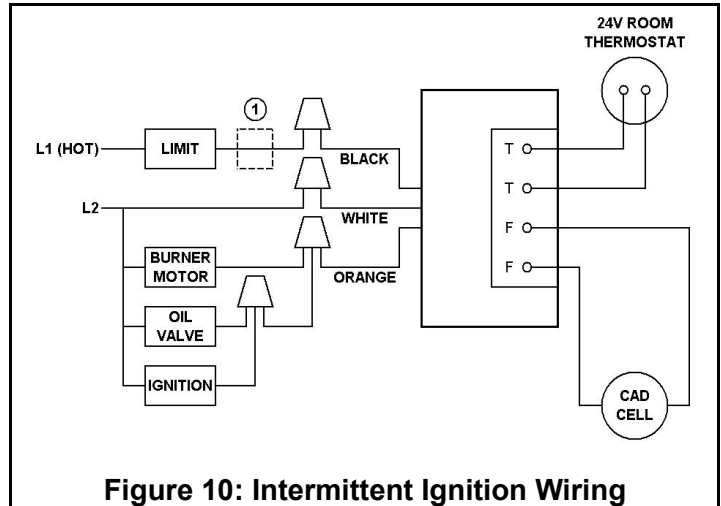

Figure 10: Intermittent Ignition Wiring

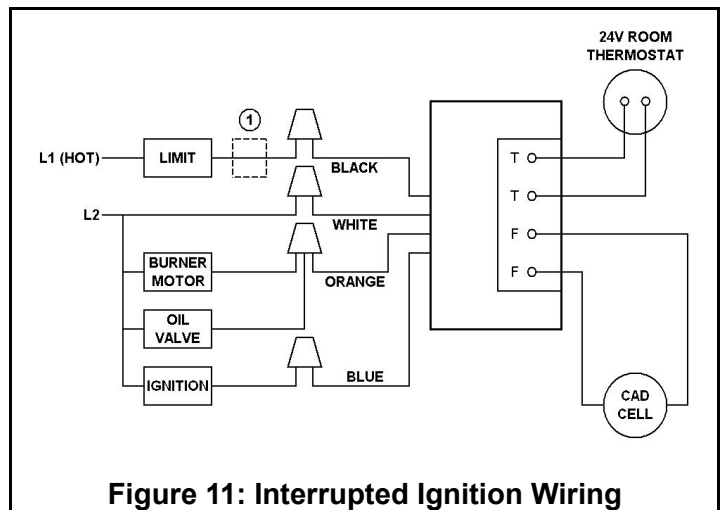

Figure 11: Interrupted Ignition Wiring

STARTING PROCEDURE

STARTING BURNER

1. Be sure main switch is in "OFF" position, thermostat is substantially above room temperature, the oil tank is filled, all valves are open, and controls set for operation.
2. Adjust air supply on burner by loosening the screw on the primary air damper, and open partially. (See Figure 12 and Table 2 for inputs and damper adjustments).

Table 2: Listed Burner Settings

GPH INPUT	FLAMELOCK SETTING "A"	STATIC BAFFLE ANGLE "B"	PRIMARY AIR DAMPER "C"
0.50 – 0.75	0 – (*0")	65°	Set to optimal
0.85 – 1.75	2 – (*1/8")	30°	CO ₂ and trace smoke.
2.00 – 3.00	8 – (*1/2")	30°	

Burner is equipped with Air Cone to fire 0.50 to 2.50 GPH, and baffle to fire 0.50 to 0.75 GPH. Use air cone 100531-001 for inputs over 2.50 GPH, and 30° baffle (packed w/manual) for inputs over 0.75 GPH.

Setting "A" - Flamelock™ settings are a direct reading in 1/16" steps. A number 2 setting indicates the Flamelock™ is 1/8 inch ahead of the Air Cone "Flush Setting". (See Figure 13)

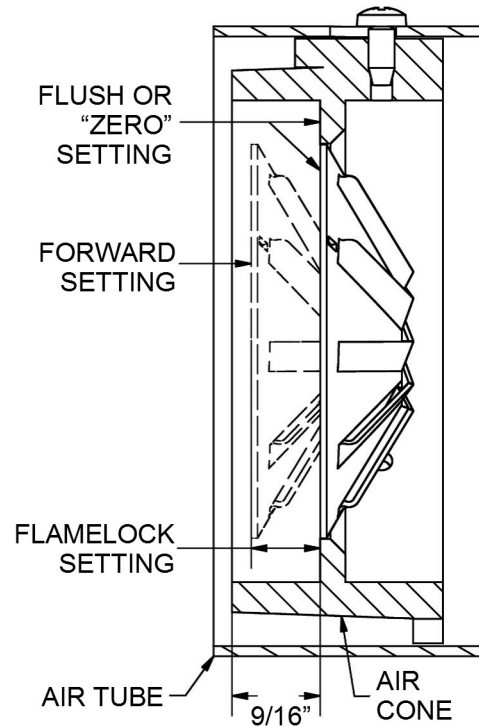

Figure 13: Flamelock Diagram

NOTICE

Note the direction of the air cone when installing it in the air tube. The beveled side of the inner diameter is installed toward the burner.

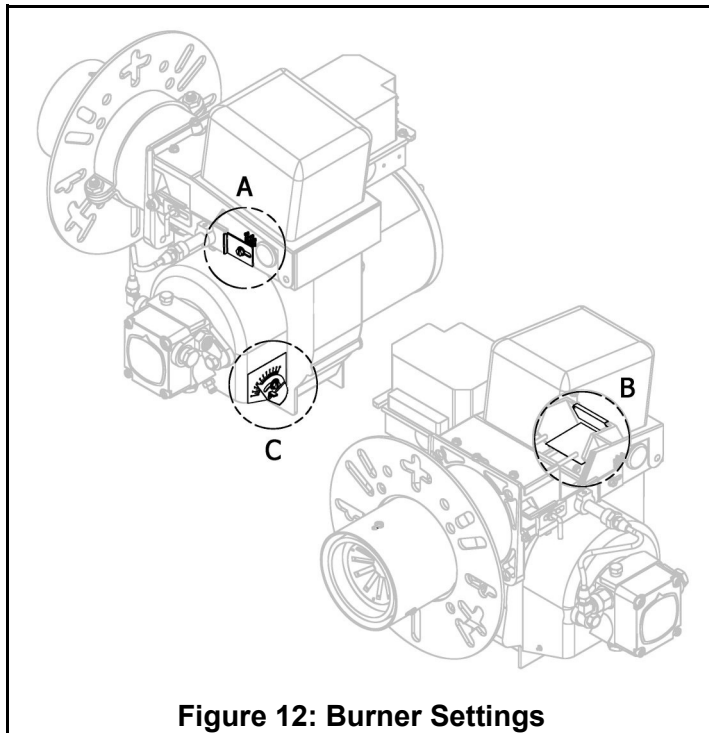

Figure 12: Burner Settings

3. Open the inspection door and turn on switch.
4. Prime pump according to the pump manufacturer's recommendations and check pressure. If safety lockout occurs, reset after one or two minutes. Do not run fuel pump dry for more than five minutes.
5. When fire is established make a temporary air adjustment for a clean combustion flame, reduce air supply until flame tips appear slightly smoky, then readjust so flame tips are clean looking.
6. Leave inspection door open until chamber is dry.
7. When normal temperatures are reached, close inspection door. (See page 3 under "Draft Regulators").

FINAL ADJUSTMENTS

1. At this point, a final adjustment should be made by the use of a COMBUSTION TEST KIT.
2. After operating ten minutes to warm up the unit, a smoke tester should be used to take a smoke reading. Smoke test should read no greater than #1 (Shell Bacarach scale), and less than a #1 smoke is desired. At times, a new heating unit requires more time than this to burn clean due to the oil film on the new heater unit surfaces.

3. Recheck draft and take a CO₂ reading over the fire and in the stack. If a large differential between CO₂ readings is noted, air leakage is the most common cause. CO₂ readings must be taken ahead of draft regulator, if used. The CO₂ measured in the stack should be at least 9% for oil rates of 1.00 GPH or below, and at least 10% for oil rates over 1.00 GPH.
4. Units should be started and stopped several times to ensure good operation.
5. Open the inspection door, turn off the valve, and check out the safety timing of the oil primary.
6. Check the operation of limit controls and thermostat.
7. Check for oil leaks.

SETTING COMBUSTION EFFICIENCY

1. Selecting firing rate desired.
2. Install proper nozzle for appliance (see page 9 under "Nozzle Selection").
3. Install proper baffle and make gun adjustments per firing rate (see Table 2 and Figure 12, page 7).
4. Fire burner, adjust combustion damper for yellow tips above combustion chamber.
5. Record CO₂ and smoke. If CO₂ is low, adjust gun setting back 1/32" and repeat CO₂ and smoke test. Continue this adjustment until optimal CO₂ and smoke is obtained. Record stack temperature.
6. Check lighting with cold and hot chamber.
7. Lock all adjustment screws, combustion damper indicator, and gun setting stop and adjusting plate.

NOTICE All new installations should be re-inspected after one or two weeks of normal operation.

FINAL CHECKS

Be sure all screws are locked, and the controls on the heating unit are adjusted in accordance with the manufacturer's instruction sheets.

Table 3: Efficiency Chart For No. 2 Fuel Oil

		NET STACK TEMPERATURE (°F)												
		300°	350°	400°	450°	500°	550°	600°	650°	700°	750°	800°	850°	900°
CO ₂	15 –	87½	86½	85¼	84¼	83¼	82	81	79¾	78¾	77½	76½	75½	74¼
	–	87½	86¼	85	84	83	81¾	80¾	79¼	78½	77¼	76	75	73¾
	14 –	87¼	86	84¾	82¾	82¾	81½	80¼	79	78	76¾	75½	74½	73
	–	87	85¾	84½	83½	82½	81¼	80	78¾	77½	76¼	75¼	74	72¼
	13 –	86¾	85½	84¼	83¼	82	80¾	79½	78¼	77	75¾	74½	73½	71¾
	–	86½	85¼	84	83¼	81½	80¼	79	77¾	76½	75¼	73¾	72¾	71
	12 –	86¼	85	83¾	82½	81¼	79¾	78½	77¼	75¾	74½	73	71½	70¼
	–	86	84¾	83½	82	80¾	79¼	78	76½	75¼	73¾	72¼	70¾	69½
	11 –	85¾	84½	83	81½	80¼	78¾	77¼	75¾	74½	73	71½	70	68½
	–	85½	84	82½	81	79½	78	76½	75	73¾	72	70½	69	67½
	10 –	85	83½	82	80½	78¾	77¼	75¾	74¼	72¾	71	69½	68	66¼
	–	84½	83	81½	79¾	78	76½	75	73¼	71¾	70	68¼	66¾	65
	9 –	84	82¼	80¾	79	77¼	75¾	74	72¼	70¾	68¾	67	65¼	63½
	–	83½	81¾	80	78¼	76½	74¾	73	71¼	69½	67½	65½	63¾	62
8 –	83	81	79¼	77½	75½	73¾	71¾	70	68	66	64	62	60	
–	82¼	80¼	78½	76½	74½	72½	70½	68½	66½	64¼	62¼	60	58	
7 –	81½	79½	77¼	75¼	73¼	71	69	67	64¾	62½	60¼	57¾	55½	
–	80¾	78½	76¼	74	71¾	69½	67¼	65	62¾	60¼	57¾	55½	53	
6 –	79¾	77¼	75	72½	70	67¾	65¼	62¾	60¼	57½	55½	52½	50	
–	78½	76	73½	71	68	65½	63	60¼	57½	54½	51¾	49	46½	
5 –	77¼	74½	71¾	69	65¾	63	60	57	54	51	48	45½	42½	
–	75½	72½	69	66¼	63	60	56¾	53½	50¼	47	43½	40¼	36¾	
4 –	73¼	69¾	66¼	62¾	59¼	55¾	52	48½	45	41¼	37½	33¾	30	

BURNER MAINTENANCE

SCHEDULED MAINTENANCE

OILING MOTOR

Proper lubrication of the motor will prolong its service life. Oil sleeve bearing motors with 6 drops of SAE 20 oil once a year. DO NOT OVER OIL. Ball-bearing motors do not require oiling under normal service conditions. The bearing type is printed on the motor nameplate.

FILTER

The oil filter cartridge should be replaced once a year so the fuel oil will not become contaminated and plug up fuel pump and nozzle of oil burner.

NOZZLE

The nozzle should be changed at least once a year before the start-up of the heating season. Replace with proper nozzle.

NOTICE

Do not touch filter or touch face of nozzle during handling. This could foil the filter or impact the spray pattern due to contamination.

FAN & BLOWER HOUSING

This must be kept clean, free of dirt and lint. Open the transformer and off cycle damper to check fan blades from above.

ELECTRODE SETTINGS

This is very important for reliable ignition of the oil; check these once a year in accordance with the instructions provided in this manual. Replace electrodes if worn excessively or if porcelain insulator is oil soaked or cracked.



CAUTION

Be sure the electric power is off burner when the transformer/cover is opened up for this inspection.

OTHER COMPONENTS

If for any reason any of the burner parts must be replaced, always use parts recommended by the manufacturer. Specify part number and item description when ordering.

NOTICE

In all communications, state burner model and serial numbers. Go to www.waynecombustion.com and enter the complete specification number in the "Product Search" box to generate a parts list for your specific burner.

BLOWER WHEEL REPLACEMENT

If the blower wheel or motor is ever replaced or removed, the spacing between the blower and the motor must be checked to ensure proper burner function.

The proper spacing is 9/64" (or 0.140") between the fan and the motor face. This is slightly more than 1/8".

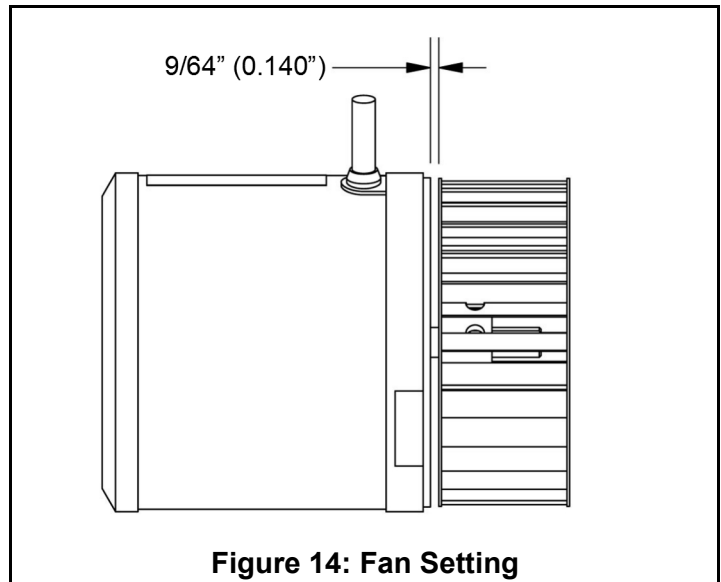

Figure 14: Fan Setting

SUNTEC PUMP INSTALLATION INFORMATION

GENERAL INFORMATION

Long or oversized inlet lines may require the pump to operate dry during initial bleeding period. In such cases, the priming may be assisted by injecting fuel oil into the pump gearset. Under lift conditions, lines and fittings must be air tight. To assure this, "Pipe Dope" may be applied to both the used and unused inlet, and both return fittings.



CAUTION

Do not use Teflon tape or compression fittings!

MOUNTING POSITION

Model "A" Single Stage Fuel Pump may be mounted in any position. Model "B" Two Stage Fuel Pump may be mounted in any position except upside down (1/8" ports pointed down).

VACUUM CHECK

In single pipe installations, a Vacuum Gage may be installed in either of the 1/4" inlet ports or in the 1/8" return port, whichever is most convenient. The Model "A" pump should be used where the vacuum does not exceed 6" Hg. single pipe and 12" Hg. two pipe. The Model "B" pump should be used where vacuum does not exceed 17" Hg.

Remember, running vacuum is the total of all pressure drops (ΔP) in the system from the tank to the inlet of the pump.

PRESSURE CHECK

NOTICE If a pressure check is made use gage port or nozzle port. do not use Easy Flow Bleed Valve Port for the for the 7000 series.

The Easy Flow Bleed Valve Port contains pressure higher than operating pressure. Setting pump pressure with gage in the Easy Flow Bleed Valve Port results in WRONG operating pressure. The 2000 series and 7400 series are exceptions (See Figure 17).

CUTOFF PRESSURE

Average cutoff pressure for model "A" and "B" fuel pumps is 80 psig. To check cutoff pressure, install pressure gage in nozzle port. Run burner for short period of time. Shut burner off. Gage shows cutoff pressure.

CAUTION Pressurized or gravity feed installations must not exceed 10 psi on inlet line or return line at the pump. A pressure greater than 10 psi may cause damage to the shaft seal.

SOLENOID WIRING

CAUTION Disconnect power supply before wiring to prevent electrical shock or equipment damage.

Lead wires on these devices are long enough to reach the junction box on most burner installations.

For all other applications, wire solenoid in parallel with burner motor (see Figure 15). All electrical work should be done according to local and national codes. (Solenoid 115V, 0.1 A, 60 HZ)

NOTICE See Figures 10 and 11, page 6 for complete wiring diagram.

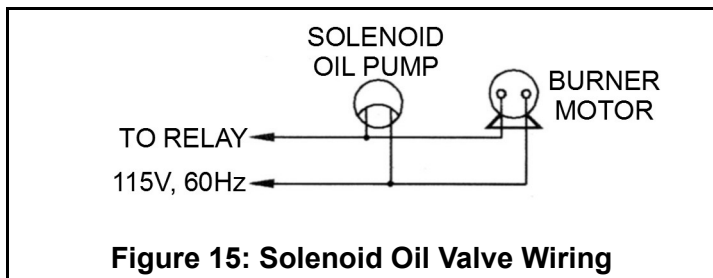

Figure 15: Solenoid Oil Valve Wiring

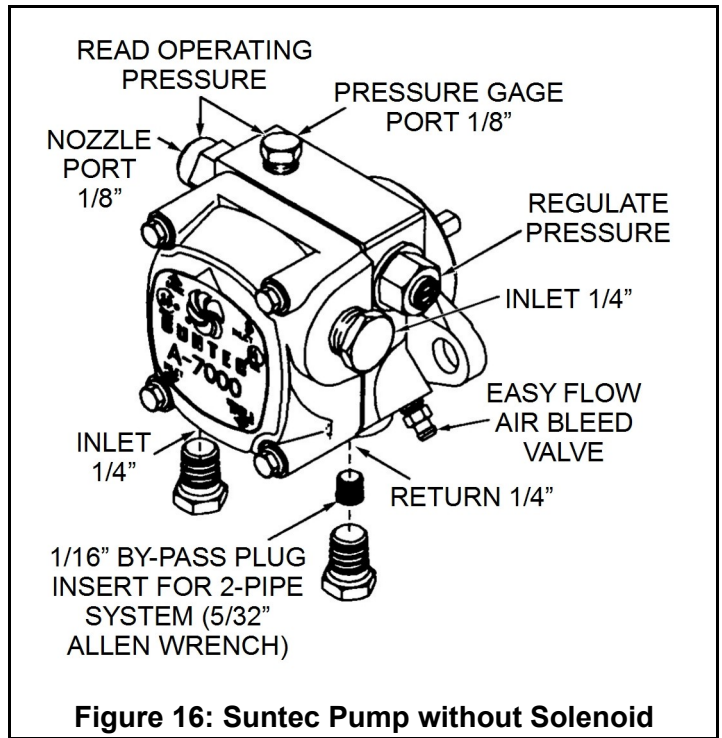

Figure 16: Suntec Pump without Solenoid

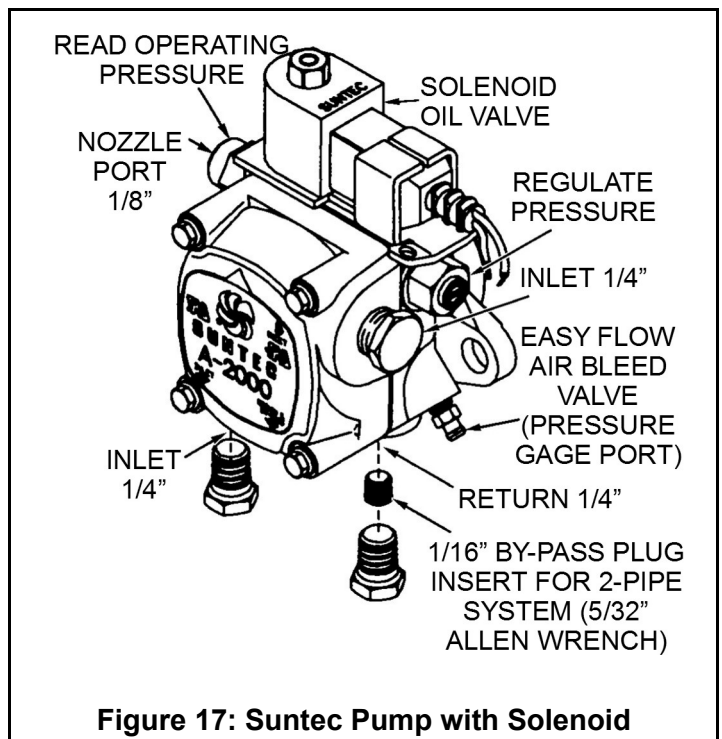
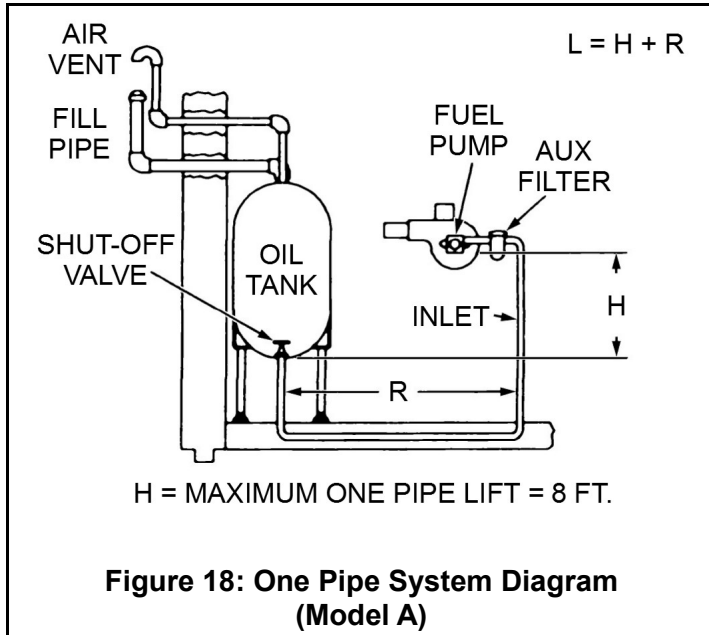

Figure 17: Suntec Pump with Solenoid

ONE-PIPE SYSTEM – MODEL A

Do not install bypass plug! Connect inlet line to pump inlet. Start burner. Arrange primary burner control for continuous operation during purging. Open easy flow bleed valve 1 turn CCW. Bleed pump until all air bubbles disappear. Tighten Easy Flow Bleed Valve securely.

NOTICE Hurried bleeding will impair efficient operation of pump.



The SUNTEC MODEL "A" FUEL PUMP may be installed ONE-PIPE with Gravity Feed or Lift. The maximum allowable lift is 8 ft. (See Figure 18).

NOTICE One-pipe installations must be absolutely air tight, otherwise, leaks or loss of prime may result. Bleed line and fuel pump completely. Bleed for 15 seconds after last air is seen from Easy Flow to be certain lines are air free.

$$\text{3/8" line } L = \frac{6 - 0.75H}{0.0086Q} \qquad \text{1/2" line } L = \frac{6 - 0.75H}{0.00218Q}$$

L = line length in feet
 H = head in feet
 Q = firing rate in GPH

If tank is above pump, change - to +. Fittings, valves, and filters will reduce total length allowed.

TWO-PIPE SYSTEM – MODEL A & B

Remove 1/16" bypass plug from plastic bag attached to pump. Remove 1/4" plug from return port. Insert bypass plug (See Figure 16 or Figure 17). Attach return and inlet lines. Start burner (air bleeding is automatic). Opening Easy Flow Air Bleed Valve will allow a faster bleed, if desired. Return line must terminate 3" to 4" above supply line inlet (see Figure 19). Failure to do this may introduce air into the system and could result in the loss of prime.

Always terminate return line as shown in Figure 19. Line lengths include both vertical and horizontal lengths.

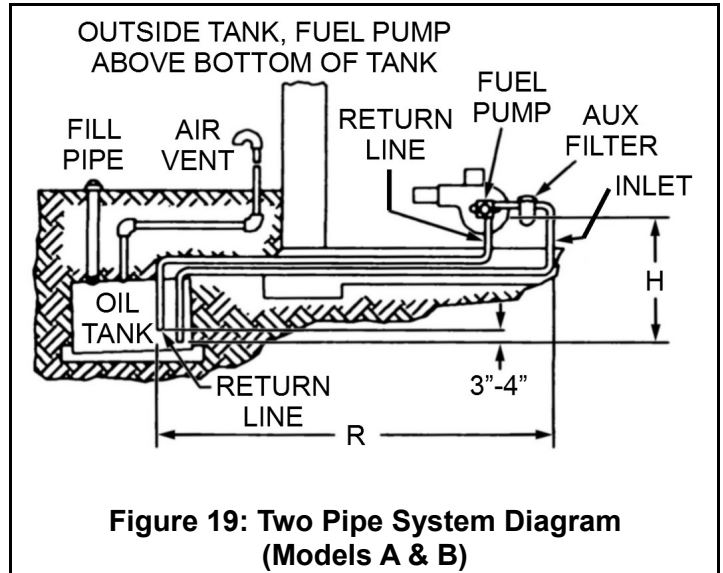

Table 4: Single Stage, Two-Pipe Maximum Line Length (H + R)

Lift "H" (Figure 19)	1725 RPM		3450 RPM			
	3/8" OD Tubing	1/2" OD Tubing	3/8" OD Tubing		1/2" OD Tubing	
	3GPH	3GPH	3GPH	7GPH	3GPH	7GPH
0'	86'	100'	84'	71'	100'	100'
1'	80'	100'	78'	66'	100'	100'
2'	75'	100'	73'	62'	100'	100'
3'	70'	100'	68'	57'	100'	100'
4'	64'	100'	63'	53'	100'	100'
5'	59'	100'	57'	48'	100'	100'
6'	54'	100'	52'	44'	100'	100'
7'	49'	100'	47'	39'	100'	100'
8'	43'	100'	42'	35'	100'	100'
9'	37'	100'	36'	31'	100'	100'
10'	32'	100'	31'	27'	100'	100'
11'	26'	100'	26'	22'	100'	87'
12'	21'	85'	21'	18'	83'	70'
13'	-	63'	-	-	62'	52'
14'	-	42'	-	-	41'	35'

**Table 5: Two-Stage, Two-Pipe
Maximum Line Length (H + R)**

Lift "H" (Figure 19)	1725 RPM				3450 RPM			
	3/8" OD Tubing		1/2" OD Tubing		3/8" OD Tubing		1/2" OD Tubing	
	3GPH	3GPH	3GPH	3GPH	3GPH	7GPH	3GPH	7GPH
0'	100'	91'	100'	100'	93'	80'	100'	100'
2'	100'	83'	100'	100'	85'	73'	100'	100'
4'	89'	75'	100'	100'	77'	66'	100'	100'
6'	80'	67'	100'	100'	69'	59'	100'	100'
8'	70'	59'	100'	100'	60'	52'	100'	100'
10'	61'	51'	100'	100'	52'	45'	100'	100'
12'	51'	43'	100'	100'	44'	38'	100'	100'
14'	41'	35'	100'	100'	36'	31'	100'	100'
16'	32'	27'	100'	100'	27'	24'	100'	100'
18'	22'	--	88'	74'	--	--	76'	65'

Table 7: Strainer and Nozzle Rotation

STRAINER TYPE	U.L. STRAINER RATING (GPH)*	DESIGNATOR	ROTATION/NOZZLE LOCATION
	#2 FUEL OIL		
V	3	A	RH/RH
Y	7	B	RH/LH
T	23	C	LH/LH
G	34	D	LH/RH

* Maximum firing rate not to exceed maximum nozzle capacity or strainer rating, whichever is LESS. A greater firing rate requires a suitable external strainer.

NOTICE

All installations should be made with local and national codes.

PUMP USAGE IDENTIFICATION

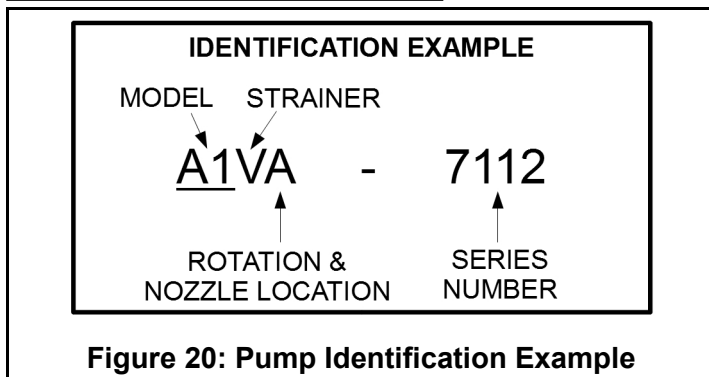

Figure 20: Pump Identification Example

Table 6: Max Nozzle Capacity for Various Pump Models

MODEL	MAX. NOZZLE CAPACITY (GPH) AT 100 PSI	RPM
A2V-2000	3	3450
A1V-7100	3	1725
A2V-7100	3	3450
A2V-7400	3	3450
A1Y-7900	7	1725
A2Y-7900	7	3450
B1V-8200	3	1725
B2V-8200	3	3450
B1Y-8900	7	1725
B1Y-8900	7	3450

NOZZLE SELECTION

Use the nozzle with the proper size, type and spray angle that the heater manufacturer recommends.

There are 3 different nozzle types: Hollow Cone (Type A), Solid Cone (Type B), or Partially Solid (Type W).

Hollow cone nozzles are generally used in burners with a hollow air pattern and also for use in burners firing at less than 1.00 GPH. Hollow cone nozzles generally have more stable spray angles and patterns under adverse conditions than solid cone nozzles of the same flow rate.

Solid cone nozzles produce a spray that distributes droplets uniformly throughout the complete pattern. These nozzles are generally used in larger burners firing above 2.00 or 3.00 GPH to provide smoother ignition. They can also be used where the air pattern of the burner is heavy in the center or where long fires are required.

Type W nozzles produce a spray that is neither completely hollow nor solid. These nozzles frequently can be used in place of either solid or hollow cone nozzles between 0.40 GPH and 8.00 GPH, regardless of the burner's air pattern. The lower flow rates tend to be hollow. Higher flow rates tend to be more solid. Type W nozzles can be used in place of A or B types to reduce specific problems.

The nozzle size is defined by the gallons of oil used per hour at a pump pressure of 100 psi. Table 8 shows the effects of pressure on nozzle flow rates.

Table 8: Effects of Pressure on Nozzle Flow Rate

Nozzle Rating at 100 PSI	Nozzle Flow Rates in Gallons Per Hour (Approx.)					
	120 PSI	145 PSI	160 PSI	175 PSI	200 PSI	300 PSI
0.4	0.44	0.48	0.51	0.53	0.57	0.69
0.5	0.55	0.60	0.63	0.66	0.71	0.87
0.6	0.66	0.72	0.76	0.79	0.85	1.04
0.7	0.71	0.78	0.82	0.86	0.92	1.13
0.8	0.82	0.90	0.95	0.99	1.06	1.30
0.9	0.93	1.02	1.08	1.12	1.20	1.47
0.9	0.99	1.08	1.14	1.19	1.27	1.56
1.0	1.10	1.20	1.26	1.32	1.41	1.73
1.1	1.20	1.32	1.39	1.46	1.56	1.91
1.2	1.31	1.44	1.52	1.59	1.70	2.08
1.3	1.37	1.51	1.58	1.65	1.77	2.17
1.4	1.48	1.63	1.71	1.79	1.91	2.34
1.5	1.64	1.81	1.90	1.98	2.12	2.60
1.7	1.81	1.99	2.09	2.18	2.33	2.86
1.8	1.92	2.11	2.21	2.32	2.47	3.03
2.0	2.19	2.41	2.53	2.65	2.83	3.46
2.3	2.46	2.71	2.85	2.98	3.18	3.90
2.5	2.74	3.01	3.16	3.31	3.54	4.33
2.8	3.01	3.31	3.48	3.64	3.89	4.76
3.0	3.29	3.61	3.79	3.97	4.24	5.20
3.3	3.56	3.91	4.11	4.30	4.60	5.63
3.5	3.83	4.21	4.43	4.63	4.95	6.06
4.0	4.38	4.82	5.06	5.29	5.66	6.93
4.5	4.93	5.42	5.69	5.95	6.36	7.79
5.0	5.48	6.02	6.32	6.61	7.07	8.66

Table 9: Suggested Spray Angles for Different Combustion Chambers

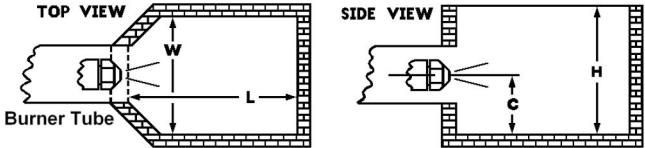

Nozzle Size or Rating (GPH)	Spray Angle	Square or Rectangular Combustion Chamber				Round Chamber (Diameter in Inches)
		L Length (in.)	W Width (in.)	H Height (in.)	C Nozzle Height (in.)	
0.50 – 0.65	80°	8	8	11	4	9
	60°	10	8	12	4	*
0.75 – 0.85	80°	9	9	13	5	10
	45°	14	7	12	4	*
1.00 – 1.10	60°	11	9	13	5	*
	80°	10	10	14	6	11
	45°	15	8	11	5	*
1.25 – 1.35	60°	12	10	14	6	*
	80°	11	11	15	7	12
	45°	16	10	12	6	*
1.50 – 1.65	60°	13	11	14	7	*
	80°	12	12	15	7	13
	45°	18	11	14	6	*
1.75 – 2.00	60°	15	12	15	7	*
	80°	14	13	16	8	15
	45°	18	12	14	7	*
2.25 – 2.50	60°	17	13	15	8	*
	80°	15	14	16	8	16
	45°	20	13	15	7	*
3.00	60°	19	14	17	8	*
	80°	18	16	18	9	17

* Recommend oblong chamber for narrow sprays.

The spray angle is determined by the size of the combustion chamber and the gallons per hour required of the appliance. The spray angle is important to keep the oil from touching the sides of the combustion chamber. Table 9 shows suggested spray angles for different combustion chambers.

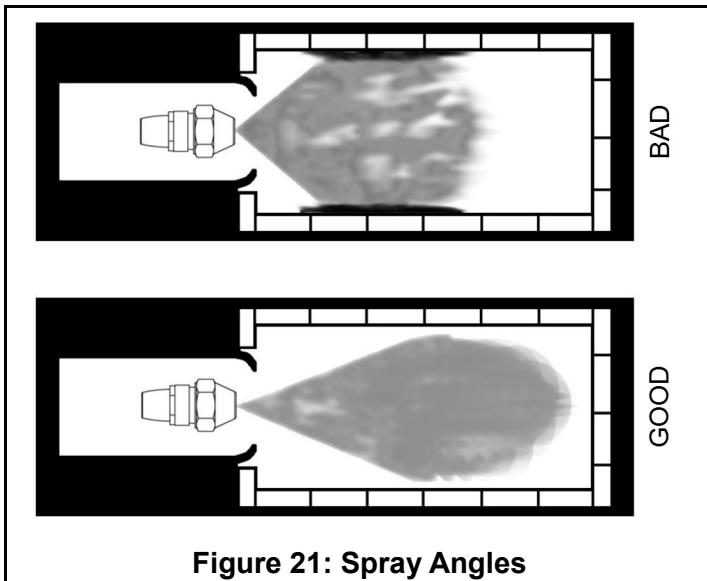

NOTICE Information presented on nozzle selection was taken from Delavan Service Technician Reference Guide.

OIL PRIMARY SPECIFICATIONS

The 101343-SER Electronic Oil Primary is a line voltage, safety rated, oil primary control for residential oil fired burners used in boilers, forced air furnaces and water heaters. The 101343-SER used with a cad cell flame sensor, operates an oil burner and optional oil valve. The primary controls fuel oil delivery, senses flame, controls ignition spark (either interrupted or intermittent) and notifies a remote alarm circuit when in lockout.

The 101343-SER can be used with both hydronic and forced air systems. When used with hydronic systems, line voltage switching Aquastat® Controllers normally provide for the starting and stopping of the combustion sequences. With forced air systems, both mechanical and electronic low voltage thermostats control the starting and stopping of the combustion process.

The 101343-SER is intended for use only on oil burning appliances, which do not require pre-purge and post-purge as a safety related function as defined in UL296. The valve-on delay and burner motor-off delay in this control are intended only to help establish draft and reduce oil after-drip related problems.

The 101343-SER can be used with EnviraLink® monitoring systems and hand-held diagnostics, such as, the QuickLook 72 by OnWatch. <http://www.onwatchinc.com/>

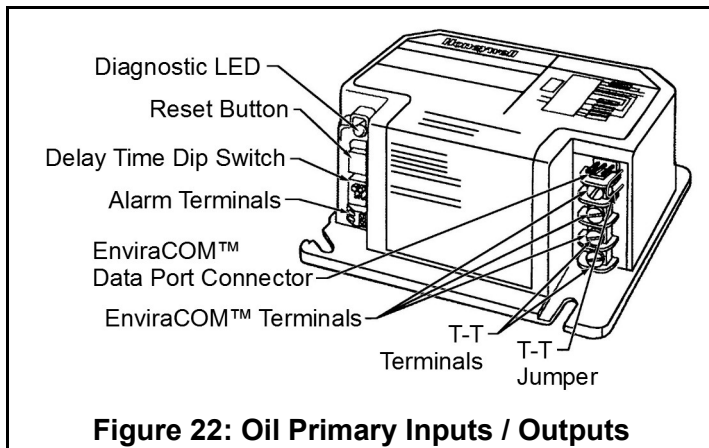

Figure 22: Oil Primary Inputs / Outputs

FEATURES

Thermostat(s)

The oil primaries are compatible with both standard thermostats and EnviraCOM™ communicating thermostats.

Limited Recycle

This feature limits the number of recycle trials (for each call for heat) to a maximum of three trials. If the flame is lost three times and does not successfully satisfy a call for heat, the 101343-SER locks out.

Pump Priming Cycle

To facilitate purging air from the oil lines and filters, the 101343-SER can be placed in a purge routine. The purge routine is started by pressing and releasing the reset button within 15 seconds after the burner motor starts. The lockout timing will be extended to four minutes and the ignition set

in the intermittent mode for this cycle only. The 101343-SER automatically reverts to its labeled interrupted and safety switch timing states (as applicable).

The pump priming cycle can only be entered if there have been no lockout occurrences since the last successful heat call. To reset the device so that the pump priming cycle can be entered, press and hold the reset button until the light emitting diode (LED) flashes (approximately 30 seconds).

Data Port

Controls are designed to allow networking and upgrade modules to be added in the field by simply plugging them into the data port/network

Disable Function

Pressing and holding the reset button will disable all functions until the button is released. The 101343-SER will restart at the beginning of the normal heat cycle on safety check.

Limited Reset (Restricted Mode)

In order to limit the accumulation of unburned oil in the combustion area, the control can only be reset three times. The reset count returns to zero each time a call for heat is successfully completed.

To reset from restricted mode: Press and hold the reset button for 30 seconds. When the LED flashes once for one second, the device has reset.

Lockout Mode

The 101343-SER will enter the lockout mode when:

- Flame is detected during valve-on delay.
- When flame is not established during Trial for Ignition.
- When flame is lost three times in one call for heat.
- When flame is detected during burner motor-off delay period.

Diagnostic LED

The diagnostic LED has four states:

1. On-Flame present.
2. Off-No flame.
3. Two seconds on, two seconds off-Recycle.
4. 1/2 second on, 1/2 second off-Lockout.

Cad Cell Resistance

Cad cell resistance can be checked without using an ohmmeter. During the run mode, press and release the reset button. The resulting flashes indicate the resistance.

Flashes	Cad Cell Resistance in Ohms
1	Less than 400
2	More than 400 and less than 800
3	More than 800 and less than 1600
4	More than 1600 and less than 5000

SPECIFICATIONS

Timing:

Safe Start Check: 5 seconds (approximately)
Lockout: 15, 30 or 45 seconds (factory-programmed)
Wayne Lockout Timing: 15 seconds
Recycle: 60 seconds (fixed)
Ignition Carryover: 10 seconds (fixed)

Electrical Ratings:

Inputs:

Voltage: 102 to 132 Vac, 120 Vac nominal
Current: 100 mA plus burner motor loads
Frequency: 60 Hz.

Outputs:

Burner Relay Contacts: 120 Vac, 10 full load amperes (FLA), 60 locked rotor amperes (LRA)
Thermostat Current Available: 100 mA
EnviraCOM™ Current Available: 150 mA

NOTICE

Reduce burner FLA rating by ignitor load. For example, if the ignitor draws 3A (120 Vac, 360 VA), reduce the burner motor FLA to 7A.

Typical Component Wire Color Code:

White: Neutral
Black: Line
Orange: Blower/Pump

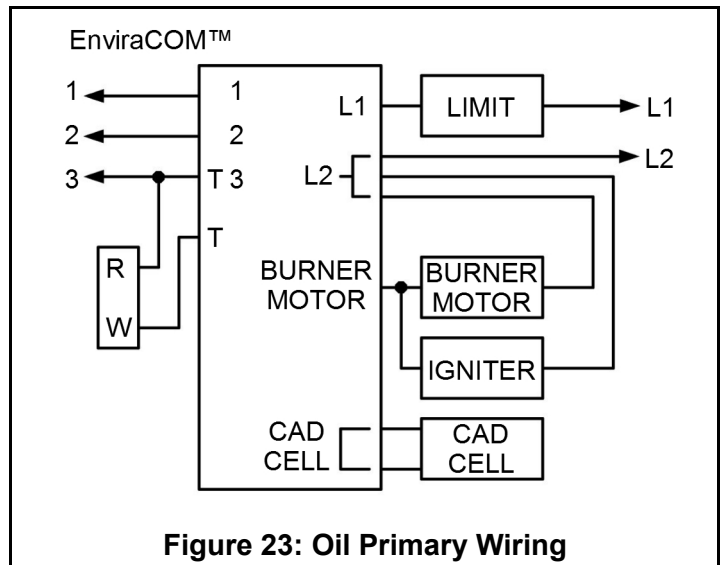

Figure 23: Oil Primary Wiring

Environmental Ratings:

Operating Ambient Temperature: -40°F to +150°F (-40°C to +66°C)
Shipping Temperature: -20°F to +150°F (-29°C to +66°C)
Humidity: 90% relative humidity at 95°F (35°C), non-condensing

Approvals:

Underwriters Laboratories Inc.: Recognized (File MP268).
Canadian Underwriters Laboratories Inc.

BURNER REPLACEMENT PARTS – MODEL HS

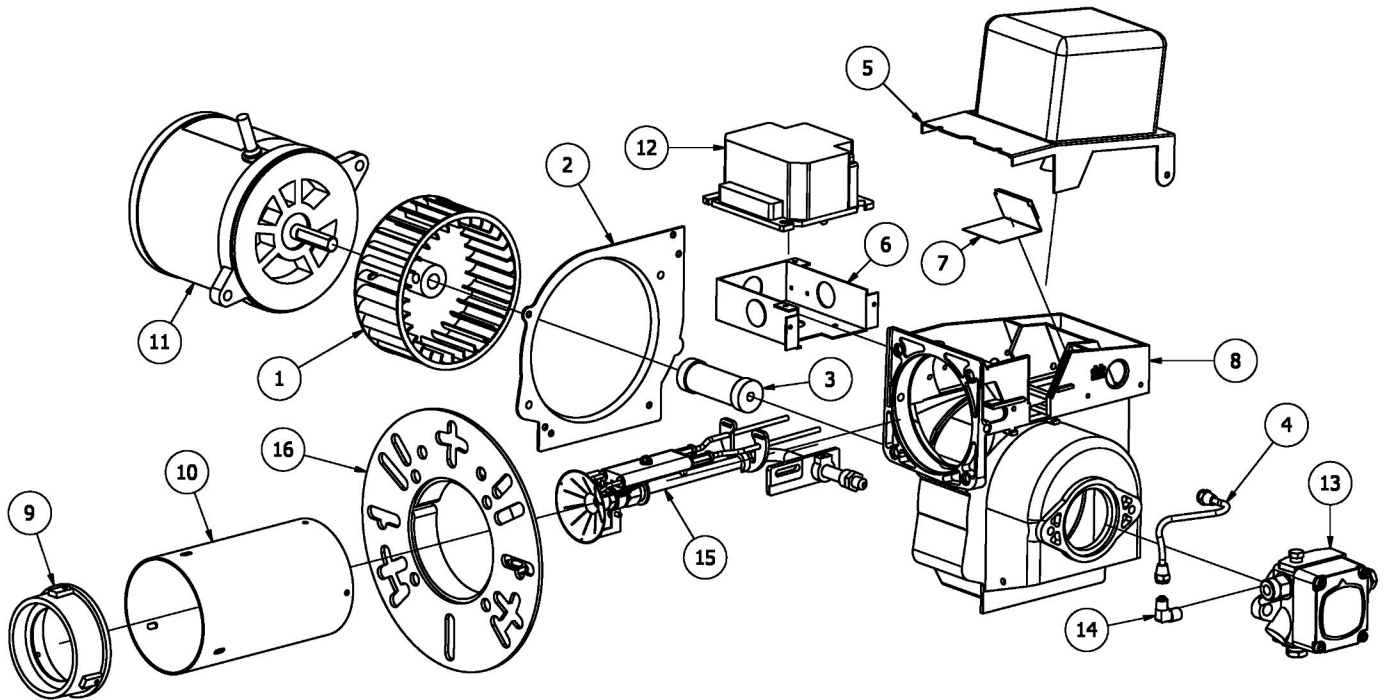

STATE SPECIFICATION NUMBER, BURNER MODEL, PART DESCRIPTION AND PART NUMBER WHEN ORDERING PARTS

No.	Description	Part No.	No.	Description	Part No.
1	Blower Wheel	21642		Air Tube 15"	21672-049
2	Motor Side Plate	21658		Air Tube 18"	21672-061
3	Coupling	100386	11	Motor, 1/7 HP, 120V/60Hz	20627
4	Oil Line Assembly 6"	14451	12	Oil Primary, 120V, 15 sec. lockout	101343-SER
5	Transformer Assembly	23101-HS	13	Fuel Pump Type A Suntec-1 Stage	13495
6	J-Box	21319		Fuel Pump Type B Suntec-2 Stage	13634
7	Baffle, Static-65°	63266-006	14	Elbow	13494
	Baffle, Static-30°	63266-013	15	Gun Assembly 6"	100926-013
8	Housing	100935-001		Gun Assembly 9"	100926-025
9	Air Cone 0.50 – 2.50 GPH	100420		Gun Assembly 12"	100931-037
	Air Cone 2.50 – 3.00 GPH	100531-001		Gun Assembly 15"	100931-049
10	Air Tube 6"	21672-013		Gun Assembly 18"	100931-061
	Air Tube 9"	21672-025	16	Adjustable Flange (Incl. Gasket)	21724-011
	Air Tube 12"	21672-037	17	Tune up Kit (Not Shown)	100950-001

GUN ASSEMBLY DETAILS – MODEL HS

No.	Description	Part No.
1	Flamlock Assembly 10 Vane	100393-SER
2	Nozzle Adapter	12362
3	Electrode Assembly – All Units*	100989-061
4	Buss Bar Support	13276-002

* Cut contact rods to length in field.

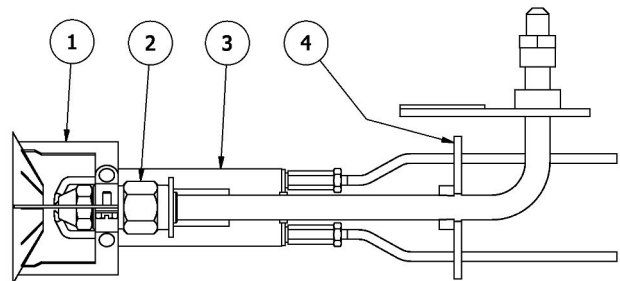

NOTICE Replacing any gun assembly components may necessitate re-calibrating of the Flamlock™ air cone (See page 6)

BLUE ANGEL™ REPLACEMENT AIR TUBE COMBINATIONS

Includes Air Tube, Air Cone and Gun Assembly

Air Tube Combination – 6".....30884-013C	Air Tube Combination – 15".....30884-049C
Air Tube Combination – 9".....30884-025C	Air Tube Combination – 18".....30884-061C
Air Tube Combination – 12".....30884-037C	

Phone: 260-425-9200 • Fax: 260-424-0904 or 1-800-345-0341

Wayne[®] Fuel Blend
CAUTION COMBUSTIBLE LIQUID
Contains Kerosene



Vapor harmful. May cause respiratory tract irritation, central nervous system depression, skin and eye irritation. Avoid breathing vapor or contact with skin or eyes. Keep container closed. Use only with adequate ventilation. Wash thoroughly after handling. Aspiration hazard if swallowed, can enter lungs and cause damage. Keep away from extreme heat, sparks, open flame, and strongly oxidizing conditions.

INHALATION: If adversely affected by vapors, get to fresh air. If not breathing, give artificial respiration. If breathing is difficult, administer oxygen. Get medical attention.

SKIN CONTACT: Wash exposed skin with soap and water. Remove contaminated clothes/shoes and wash before reuse. If persistent irritation occurs, get medical attention.

EYE CONTACT: Immediately flush with plenty of water for at least 15 minutes, lifting upper and lower eyelids frequently. If irritation or burning persists, seek medical attention.

INGESTION: Do NOT induce vomiting. Never give anything by mouth to an unconscious person. Get medical attention immediately. If spilled, contain spilled material and remove with inert absorbent. Dispose of contaminated absorbent, empty containers, and unused contents in accordance with state, local, and federal regulations.

See MATERIAL SAFETY DATA SHEET For More Information.

R-65: Harmful: may cause lung damage if swallowed.

S-23: Do not breathe vapor.

S-24: Avoid contact with skin.

S-62: If swallowed, do NOT induce vomiting. Seek immediate medical attention.

Wayne Combustion Systems
801 Glasgow Avenue • Fort Wayne, Indiana 46803



WAYNE COMBUSTION SYSTEMS

801 Glasgow Ave.
Fort Wayne, IN 48803

LIMITED WARRANTIES FOR OIL AND GAS BURNERS, MADE BY WAYNE AND USED IN RESIDENTIAL INSTALLATIONS

WAYNE COMBUSTION SYSTEMS (“WAYNE”) warrants to those who purchase its **Oil Burner Models** for resale or for incorporation into a product of resale, that its burner is free from defects in material and workmanship under normal use and service for thirty-six (36) months from the date of manufacture. **ALL GAS BURNERS** manufactured by “WAYNE” will be similarly warranted for eighteen(18) months from date of manufacture except where original manufacture offers a greater warranty. (Reference #6 below) **THESE LIMITED WARRANTIES DO NOT APPLY UNLESS THE BURNER COVERED BY IT IS PROPERLY INSTALLED BY A QUALIFIED, COMPETENT TECHNICIAN, WHO IS LICENSED WHERE STATE AND/OR LOCAL CODES PREVAIL, AND WHO IS EXPERIENCED IN MAKING SUCH INSTALLATIONS**, in accordance with NFPA #31 of the national fire protection association and in accordance with all local, state and national codes.

Any **IN-WARRANTY** burner component which is defective in material or workmanship will be either repaired or replaced as follows:

1. Fuel pumps, motors, transformers, gas valves, and controls should be returned to an authorized service station or distributor of WAYNE for determination of applicability of this LIMITED WARRANTY as to either repair or replacement, where said service station or distributor is reasonably available in the customer’s locality. The manufacturers of burner components regularly publish and distribute listings showing the locations of their network of service stations. Where such local service is NOT available for the burner components described above or other burner parts are involved, these items should be returned, freight prepaid, to WAYNE Service Department, 801 Glasgow Ave, Fort Wayne, Indiana 46803.
2. Burners and/or component(s) determined to be covered under this LIMITED WARRANTY by WAYNE shall be repaired or replaced at WAYNE’s sole option.
3. WAYNE is not responsible for any labor cost for the removal and replacement of said burner or burner components and equipment associated therewith.
4. A burner so repaired will then carry the LIMITED WARRANTY equal to the unexpired portion of the original burner LIMITED WARRANTY.
5. If inspection by WAYNE does NOT disclose any defect covered by this LIMITED WARRANTY, the burner or burner component(s) will be either repaired or replaced at the expense of the customer and WAYNE’s regular charges will apply.
6. If the original manufacturer of a burner component offers a warranty greater than either of our LIMITED WARRANTIES described above, then this portion will be added to our LIMITED WARRANTY. This LIMITED WARRANTY does NOT cover products that have been damaged as the result of accident, abuse, misuse, neglect, improper installations, improper maintenance or failure to operate in accordance with WAYNE’s written instructions.

These LIMITED WARRANTIES do not extend to anyone except the first purchaser at retail and only when the burner is in the original installation site.

IMPLIED WARRANTIES OF MERCHANTABILITY AND FITNESS FOR A PARTICULAR PURPOSE SHALL BE LIMITED TO THE DURATION OF THE LIMITED EXPRESS WARRANTIES CONTAINED HEREIN. WAYNE EXPRESSLY DISCLAIMS AND EXCLUDES ANY LIABILITY FOR CONSEQUENTIAL OR INCIDENTAL DAMAGES OF ANY NATURE FOR BREACH OF ANY EXPRESS OR IMPLIED WARRANTY.

Some states do not allow limitation on how long an implied warranty lasts, so the above limitation may not apply to you. Also, some states do not allow the exclusion or limitation of incidental or consequential damages, so the above limitation or exclusion may not apply to you. WAYNE neither assumes nor authorizes any person to assume for WAYNE any other liability or obligation in connection with the sale of these products. This warranty gives you specific legal rights, and you may also have other rights, which vary from state to state.

