

Job Name:

Job No:

JWC Representative:

Tag No.:

Submitted By:

Date:

Engineer:

Approved By:

Date:

Contractor:

Order No.:

Date:

JWEP Series

Glycol Make-up System With Top Mounted Components For Closed Loop Heating & Cooling Systems



APPLICATION

- JWEP Series glycol make-up systems are designed to maintain minimum system pressure levels. The systems are completely automatic and operate as needed to add water or water-glycol solution to a closed loop heating, chilled water, snowmelt, or radiant heat system.
- The water-glycol solution is contained in the holding tank. A pressure switch controls the flow of the glycol solution to the system.
- A low level safety switch shuts down the pump when the solution drops to the minimum fill level.
- Make-up system is designed for indoor applications.

DESIGN PRESSURE AND TEMPERATURE

- Maximum design pressure: 100 PSI (689 kPa)
- Maximum design temperature: 180° F (82° C)

TYPICAL DESIGN SPECIFICATION

Furnish and install as shown on plans John Wood Model No. JWEP-53-_____ (_____ gallon) automatic glycol make-up unit with top mounted components. The package shall consist of a polyethylene tank with removable cover and visible level scale, suction strainer with foot valve, close coupled turbine pump, check valve, relief valve with return line, instrument valve, pressure gauge, expansion tank, and necessary piping. Discharge piping shall be Schedule 40 Carbon Steel with BMI fittings and ½" FNPT system connection. Suction piping and the return line from the relief valve shall be PVC. System requires a 115/1/60 HZ power connection. Unit shall provide up to 4.3 GPM.

SPECIFICATIONS

- Cylindrical self-supporting polyethylene tank with removable cover
- Tank is calibrated in gallons for convenient visual check of contents
- Regenerative type turbine pump, 1/3 HP
 - Bronze construction with Monel impeller blades, 316 SS shaft, carbon/ceramic shaft seal
 - 3.2 GPM capacity @ 54.1 PSI (125 ft. total head)
- Includes tank fill cap with vent filter, 2.1 gallon expansion tank, pressure relief valve with return line, float switch, pressure gauge, check valve, suction strainer with foot valve
- NEMA 1 pressure switch factory setting: cut-in 40 PSIG, cut-out 60 PSIG (other switches available upon request)
 - Standard pressure range: cut-in 10 to 40 PSIG, cut-out 20 to 65 PSIG; 15 to 30 PSIG differential
- 120 VAC electrical connection (terminals included in the pressure switch enclosure; customer is responsible for electrical connection)
- ½" FNPT system connection

JWEP Series / Glycol Make-up

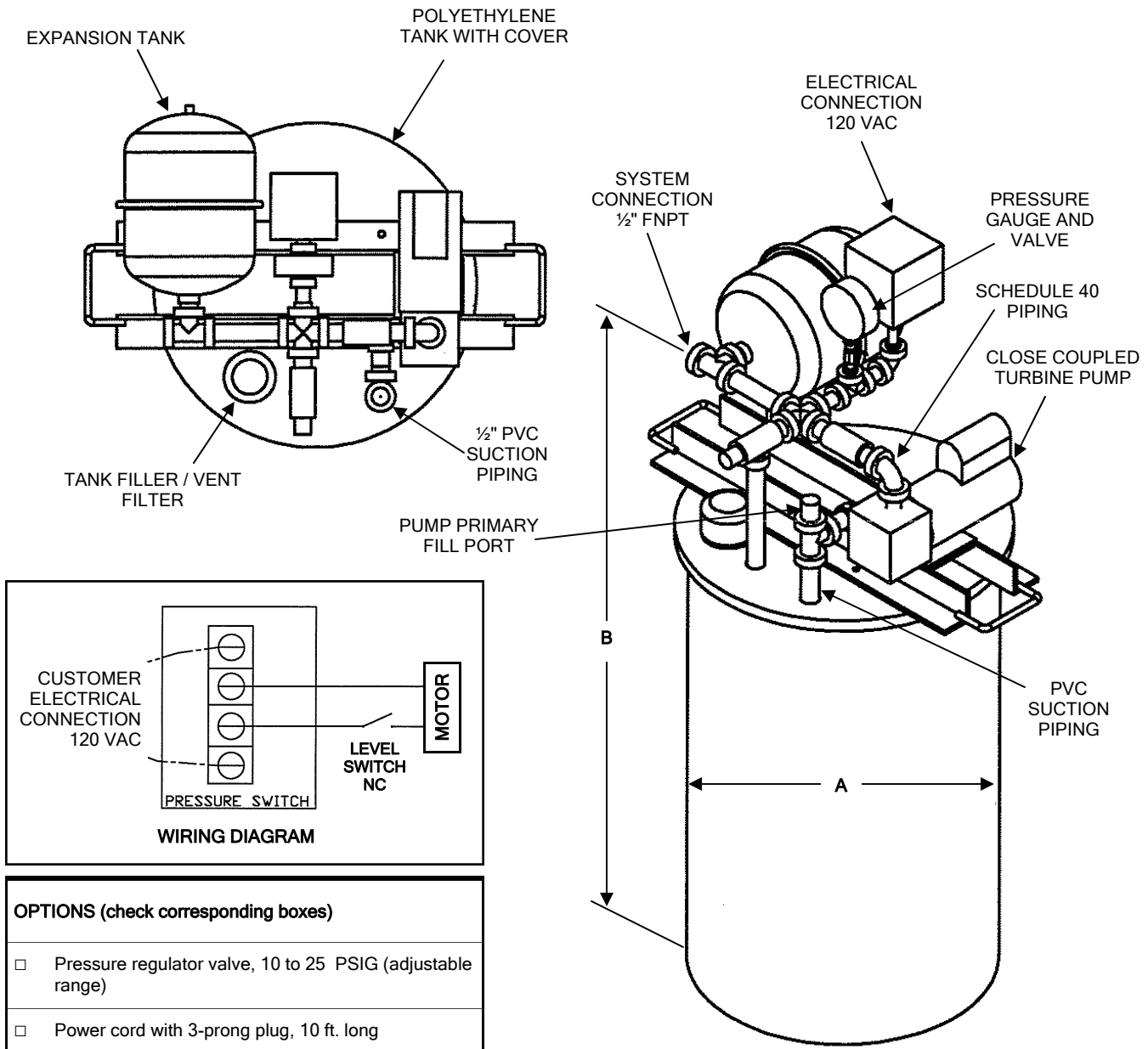

MODEL NUMBER	TURBINE PUMP	TANK VOLUME	A DIAMETER	B HEIGHT	SYSTEM CONNECTION	EST. WEIGHT
JWEP-53-030	1/3 HP	30 GAL	18"	39"	1/2" FNPT	75 LBS
JWEP-53-055	1/3 HP	55 GAL	22"	43"	1/2" FNPT	85 LBS
JWEP-53-100	1/3 HP	100 GAL	37"	58"	1/2" FNPT	95 LBS

Dimensions are subject to change.
Shipping weights are approximate.



THE JOHN WOOD COMPANY
AN ALCO INDUSTRIES COMPANY
98 Highland Avenue, Oaks, PA 19456-1052
T 610-666-1220 | 800-537-5581
F 610-666-0193