

ICM6100 Board Layout

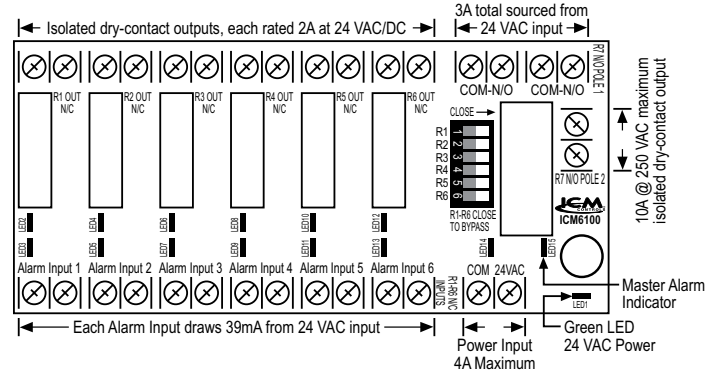

Specifications

Input

- 24 VAC; 50/60Hz (4A max)

Output

- **Relay outputs (6):** 2A @ 24 VAC/DC per output
- **Master relay 24 VAC (2):** 1.5A @ 24 VAC per output
- **Master relay dry contacts:** 10A @ 250 VAC
- **Alarm status:** – **Green LED ON** = Activated
– **Red LED ON** = Not Activated

Mechanical

- **Dimensions:** 6.000" x 2.750" x 1.250"
- 2.750" Mounting track provided

Mode of Operation

The ICM6100 combines a common relay-logic function into a less expensive, easy to use, small package.

When any input is closed, the corresponding output will open, and its green LED will turn on. A dip switch is provided to bypass inputs not being used.

The master relay will open if any of the six inputs are open, and the master relay's red LED will turn on. With the master relay closed, two sets of 24 VAC general purpose terminals as well as one set of dry-contacts (rated for 10A @ 250 VAC) are available, and the master relay's green LED will turn on.

This device is most commonly used as an Air Handling Unit safety-shutdown, whereas the master relay shuts down the fan in the event of a fault. Outputs provided ensure that a DDC controller can determine the root cause of a shutdown.

ICM6100 Wiring Diagram

