



ICM600/ICM601

Lead Lag Controller

Microprocessor controlled regulation for one or two heating/cooling systems to provide a constant temperature.



APPLICATION GUIDE

For information on our complete range of American-made products — plus wiring diagrams, troubleshooting tips and more, visit us at www.icmcontrols.com



Specifications

ELECTRICAL

Input

- **Nominal Voltage:** 18 to 30 VAC
- **Frequency:** 50 to 60 Hz

Output

- **Type:** Triac
- **Number:** Four (4)
- **Rating:** 2 amps per output @ nom. 24 VAC

OPERATIONAL

Heat/Cool Staging

- **First Stage Heat (H1):** Deadband setting above thermostat setpoint (C1)
- **Second Stage Heat (H2):** 2°F above H1
- **First Stage Cool (C1):** Equal to the thermostat setpoint
- **Second Stage Cool (C2):** 2°F below C1

Deadband

- **Adjustable:** 2°F to 20°F

Anti-short Cycle Protection

- **Stage 1:** Three (3) minutes
- **Stage 2:** Four (4) minutes

Setpoint

- **Adjustable:** 55°F to 90°F

Advance Sequencer

- **Pin selectable:** Alternates every 1, 3, 7, 14, or 28 days, or fixed
- Manual **ADVANCE** pushbutton initializes sequence period

Mode Memory

- On power loss, system “remembers” which mode it was in

Test Modes

- Thermistor bypass calibration mode jumper
- Accelerated test mode jumper

Call Lights (LEDs)

- **Green LEDs:** Call for COOL (C1 & C2)
- **Red LEDs:** Call for HEAT (H1 & H2)

Operation

Main steps for programming the Lead-Lag Controller:

1. Temperature Selection Pot
2. Deadband Pot
3. Advance Sequencer
4. Advance (Override) Switch
5. Test Mode Jumper

1. Temperature Selection Pot:

This selection pot is the temperature above which the cooling cycle begins. In cooling mode, the green “call for cool” indicator light - C1 (and C2 if second stage cooling is required) stays on. Each light corresponds to one stage of cooling. The temperature spacing between these lights is approximately 2°F. In heating mode, the red “call for heat” indicator lights, H1 and H2, operate similarly. The temperature spacing between cooling and heating modes is the deadband setting.

2. Deadband Pot:

The deadband is the range where neither heating nor cooling is necessary. The deadband adjustment moves the heating setpoints in relation to the cooling setpoints. At its minimum position (counterclockwise) the deadband is 2°F. At its maximum position the deadband is 20°F.

3. Advance Sequencer:

For 2-stage alternating installations, the advance sequencer demands equal operating time from groups A and B. Select the time interval by placing a jumper over one of the jumper pair posts. The jumper labeled “0” disables the advance timing; use it when the controller is connected to a single heating/cooling group, or when alternating operation between two heater/cooler groups is not desired. In test mode (when the test mode jumper is installed), the advance times are accelerated (see the values shown in the Test Mode Advance Time Table). In normal mode (test mode jumper removed), advance times are in days as printed on the printed circuit board (i.e. 1, 3, 7, 14, 28). Setting the controller for 7 days is appropriate for most installations.

4. Advance (Override) Switch:

The advance switch is a pushbutton switch provided to override the timing and instantaneously switch the lead group. The two red LEDs indicate which group will start first. The LED on the left is group A and the LED on the right is group B. Pressing the switch not only changes the lead group, but also restarts the anti-short cycle delay on make, and sets the main timer to zero. This feature can be used to reset the timer so the next advance time will be known.

5. Test Mode Jumper:

The test mode provides for accelerated testing of the advance (override) function of the controller and the output delay on make times. When the test mode jumper is installed, the advance time conversion is from days to seconds. Accelerated anti-short cycle delay on make times are 1 second for stage one heating/cooling, and 4 seconds for stage two heating/cooling. Test mode advance times are as specified in the table below.

TEST MODE ADVANCE TIME TABLE

Jumper Number	Advance Time (seconds)
0	• no advance •
1	1
3	3
7	7
14	14
28	28

Caution

Installation of the ICM600/ICM601 shall be performed by trained technicians only. Adhere to all local and national electric codes. Disconnect all power to the system before making any connections.

BOARD LAYOUT

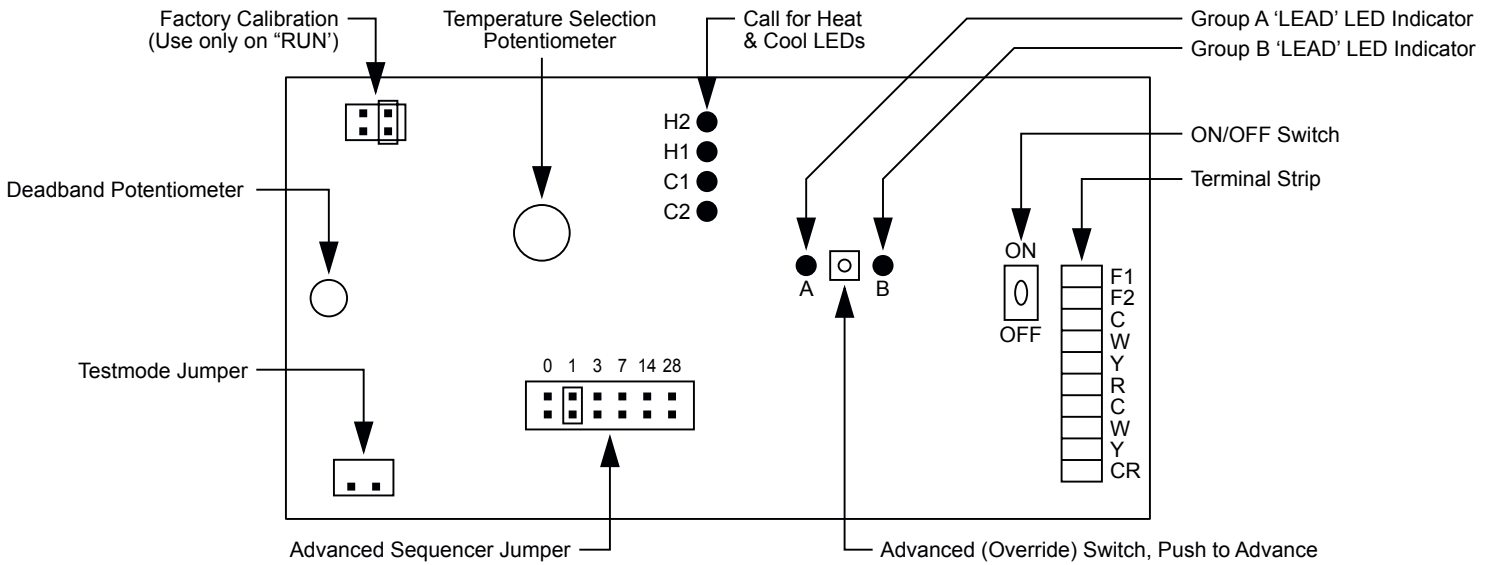

APPROXIMATE TEMPERATURE REFERENCE

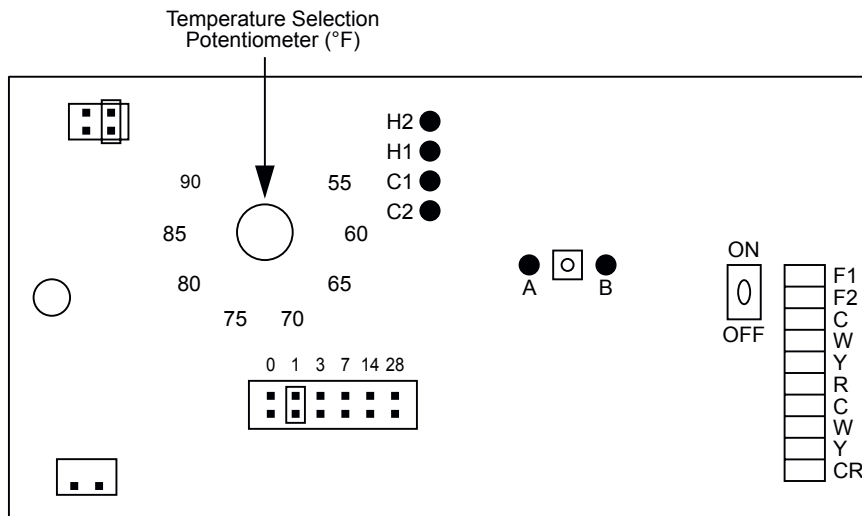

WIRING DIGRAM

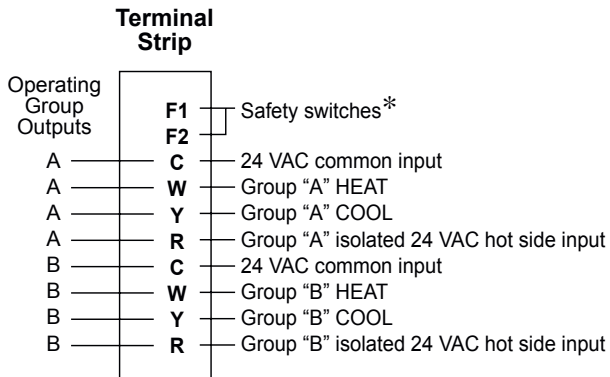

* Short F1 and F2 if you do not have safety switches

SAMPLE CONNECTION

Group "A" Heat and Group "B" Cool

