

Replaces: Reznor 195573

Features

- Direct Spark Ignition (DSI) control board
- Cooling and heating fan outputs
- Microprocessor-based
- Controls inducer motor, electronic air cleaner (if equipped), spark ignitor and the gas valves
- Monitors timing, trial for ignition, system switches, flame sensing and lockout
- Compatible with LP or natural gas
- LED indication for status and fault codes to aid in troubleshooting

Specifications

Input Voltage: 18-30 VAC Frequency: 60 Hz	Outputs Inducer blower Type: Relay Rating: 1/6 HP @125 VAC Gas Valves Type: Relay Rating: 1A @ 24 VAC	Heat blower Type: Relay Rating: 1/4 HP @125 VAC Cool blower Type: Relay Rating: 1 HP @125 VAC	Environmental Operating Temperature: -40°F to 165°F (-40°C to 74°C) Mechanical Dimensions: 14.5" x 5"
----------------------------------------------------------------------	--------------------------------------------------------------------------------------------------------------------------------------------------	--------------------------------------------------------------------------------------------------------------------------------	------------------------------------------------------------------------------------------------------------------------------------------------

Safety Considerations

Only trained personnel should install or service heating equipment. When working with heating equipment, be sure to read and understand all precautions in the documentation, on labels, and on tags that accompany the equipment. Failure to follow all safety guidelines may result in damage to equipment, severe personal injury or death.

Electrostatic Discharge (ESD) Precautions

CAUTION!

Use caution when installing and servicing the furnace to avoid and control electrostatic discharge; ESD can impact electronic components. These precautions must be followed to prevent electrostatic discharge from hand tools and personnel. Following the precautions will protect the control from ESD by discharging static electricity buildup to ground.

1. Disconnect all power to the furnace. Do not touch the control or the wiring prior to discharging your body's electrostatic charge to ground.
2. To ground yourself, touch your hand and tools to a clean, metal (unpainted) furnace surface near the control board.
3. Service the furnace after touching the chassis. Your body will recharge with static electricity as you shuffle your feet or move around, and you must reground yourself.
4. Reground yourself if you touch ungrounded items.
5. Before handling a new control, reground yourself; this will protect the control. Store used and new controls in separate containers before touching ungrounded objects.
6. ESD damage can also be prevented by using an ESD service kit.

Remove Existing Control

CAUTION!

To service control, and prior to disconnection, label all wires. Failure to do so may result in wiring errors that can cause dangerous operation.

1. Turn thermostat to OFF position or set it to the lowest possible setting.
2. Turn OFF electrical supply to furnace.
3. Turn OFF gas supply to furnace.
- * **CAUTION:** Failure to turn off gas and electric supplies can result in explosion, fire, death, or personal injury.
4. Remove furnace blower and control access doors.
5. Disconnect thermostat wires and humidifier wires (if equipped with a humidifier).
6. Disconnect line voltage, blower, electronic air cleaner wires (if equipped), and transformer wires.
7. Remove screws and any other fasteners, and the old circuit board.
8. Examine control and control box to check for water stains.
9. Make repairs if any sources of water leakage are found. Be sure to check humidifiers, evaporator coils, and vent systems in the area of the control.

Install New Control

1. Ground yourself. When handling circuit board, hold it by the edges.
2. Fasten circuit board with retaining screws.
3. Connect all line voltage, low voltage, and accessory wires.
4. Verify the sequence of operation.

Summary of Operation

Call for Heat:

Upon a call for heat from the thermostat, the control board checks to see if the limit switch is closed and the pressure switch is open. If the limit switch is closed and the pressure switch is open, the circuit board energizes the draft inducer motor and waits for the pressure switch to close. When the pressure switch is proven closed, the control board energizes the draft inducer motor for a 20 second pre-purge time. Following the pre-purge, the board energizes the spark ignitor and main gas valves and the draft inducer motor remains energized. Once the flame has been proven, the heat blower turns on after a 30 second delay. If the call for heat is removed after successful ignition, the circuit board will de-energize the gas valves and run the draft inducer motor for 45 seconds. The heat blower turns off after the user settable blower purge time delay.

Call for Fan:

If the thermostat is calling for fan, the heat blower turns on after a 1 second delay. If the call for fan is removed, the control board turns off the heat blower after 1 second.

Call for Cool:

If the thermostat is calling for Cooling, the cool blower turns on after a 7 second delay. If the call for cooling is removed, the control board turns the cool blower off after a 90 second post purge delay.

P1 Pin Connections Out Pins

- Pin 1 n/a
- Pin 2 Gas valve ground
- Pin 3 Limit switch (W)
- Pin 4 Gas valve outputs
- Pin 5 Pressure switch output
- Pin 6 Pressure switch input
- Pin 7 Flame sense input
- Pin 8 Limit switch output
- Pin 9 Flame ground

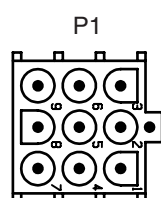

DIP Switch Settings

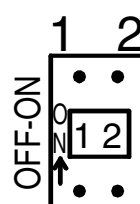

BLOWER PURGE TIMING		
Time	SWITCH 1	SWITCH 2
90	OFF	ON
120	OFF	OFF
160	ON	OFF
45	ON	ON

Wiring Diagram

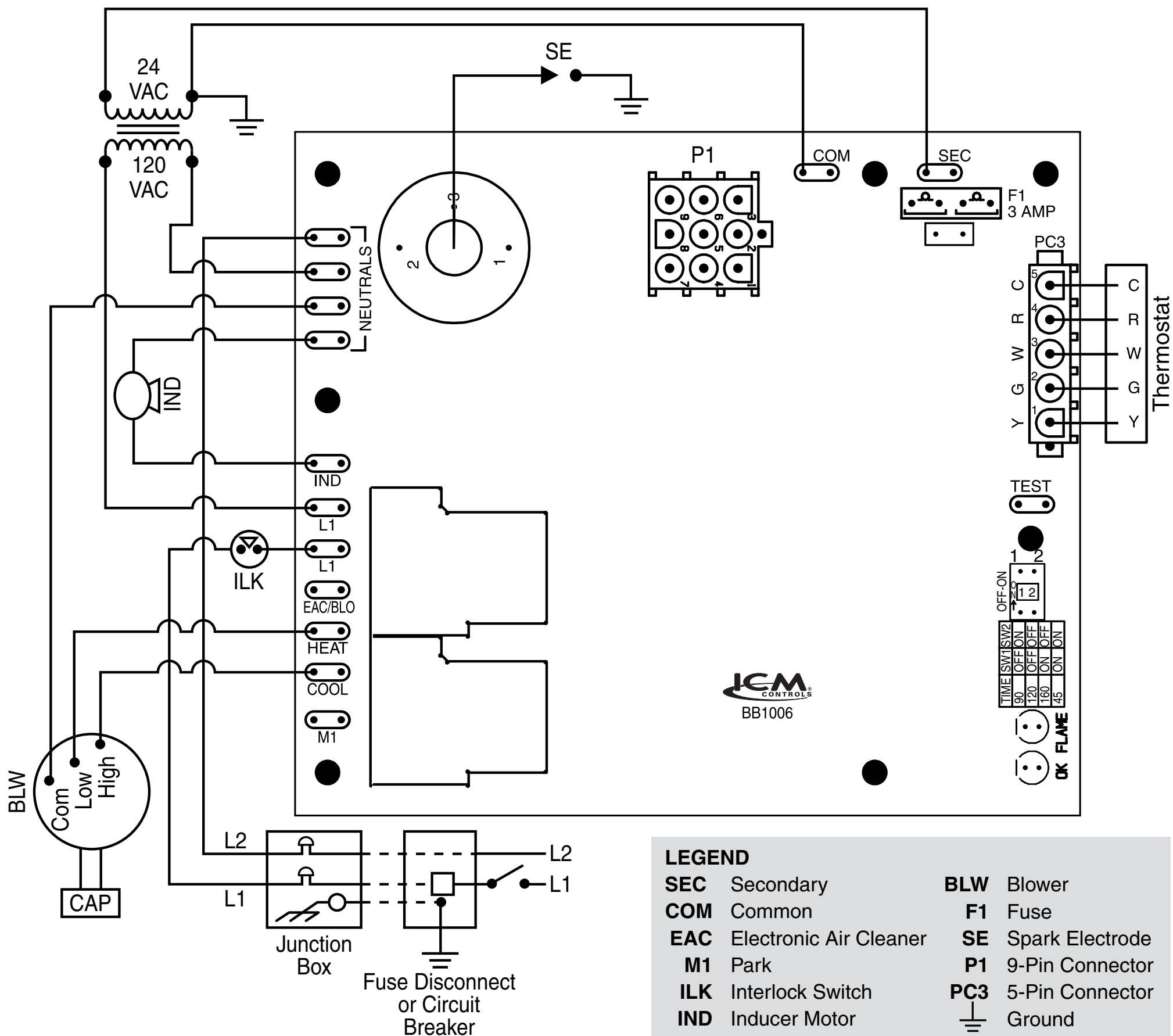

LEGEND

SEC Secondary	BLW Blower
COM Common	F1 Fuse
EAC Electronic Air Cleaner	SE Spark Electrode
M1 Park	P1 9-Pin Connector
ILK Interlock Switch	PC3 5-Pin Connector
IND Inducer Motor	⏏ Ground

Fault Code Table -- Green LED Displays the Operational Status of the Control Board

	Fault	Trouble shooting tips
LED ON	Normal operation, no call for heat	Normal
Fast Flash	Call for heat	Normal operation with a heat call
OFF	No power	Install power, check fuse box or circuit breaker
1	Ignition Failure (after 3 tries and start of soft lockout)	Check all safeties, check all grounds, check flame sensor, and insure gas valve is turned on.
2	Pressure switch failed to close within 30 seconds of inducer	Check for obstructions in the Pressure switch tube or a faulty pressure switch
3	Limit switch failed open	Check for faulty limit switch or limit switch wires. Also, check any safety in series with the limit switch.
4	Pressure switch stuck closed before inducer blower is energized	Check for faulty pressure switch.
5	Gas Valve fault detected	Check for proper gas pressure, check wiring to the gas valve, check gas valve operation.
6	Brownout Voltage	Check the primary supply line voltage with respect to ground. Check to see if anything is loading down the line voltage to the control.
Rapid	Wrong polarity of 120 VAC and Neutral.	Check the line voltage with respect to ground and neutral with respect to ground for proper polarity.

Fault Code Table -- Yellow LED displays the operational status of Flame.

	Fault	Trouble shooting tips
LED ON	Flame is sensed	Normal operation
Slow Flash	Weak Flame	Clean or replace flame sensor and check flame sense ground
Fast Flash	Flame fault	Check or replace flame sensor and check flame sense ground