

# INSTALLATION INSTRUCTIONS

## Uncased N Coil, Upflow–Downflow ENA4X

**NOTE:** Read the entire instruction manual before starting the installation.

### TABLE OF CONTENTS

	PAGE
SAFETY CONSIDERATIONS .....	1
INTRODUCTION .....	2
INSTALLATION .....	2
Procedure 1 — Inspect Equipment .....	3
Procedure 2 — Select Installation .....	4
Procedure 3 — Installation of Evaporator Coil .....	5
Procedure 4 — Connect Refrigerant Piping .....	7
Procedure 5 — Connect Refrigerant Liquid and Suction Lines .....	7
Procedure 6 — Condensate Drain Line Connection ..	7
Procedure 7 — Humidifier Application .....	8
Model Number Identification .....	9

### SAFETY CONSIDERATIONS

Improper installation, adjustment, alteration, service, maintenance, or use can cause explosion, fire, electrical shock, or other conditions which may cause death, personal injury or property damage. Consult a qualified installer, service agency, or your distributor or branch for information or assistance. The qualified installer or agency must use factory–authorized kits or accessories when modifying this product. Refer to the individual instructions packaged with the kits or accessories when installing.

Follow all safety codes. Wear safety glasses, protective clothing, and work gloves. Use quenching cloth for brazing operations. Have fire extinguisher available. Read these instructions thoroughly and follow all warning or cautions included in literature and attached to the unit. Consult local building codes and the current editions of the National Electrical Code (NEC) NFPA 70.

In Canada, refer to the current editions of the Canadian Electrical Code CSA C22.1.

Recognize safety information. When you see this symbol  on the unit and in instructions or manuals, be alert to the potential for personal injury. Understand the signal words **DANGER**, **WARNING**, **CAUTION**, and **NOTE**. These words are used with the safety–alert symbol. **DANGER** identifies the most serious hazards which **will** result in severe personal injury or death. **WARNING** signifies hazards which **could** result in personal injury or death. **CAUTION** is used to identify unsafe practices which **may** result in minor personal injury or product and property damage. **NOTE** is used to highlight suggestions which **will** result in enhanced installation, reliability, or operation.

### **WARNING**

#### ELECTRICAL SHOCK HAZARD

Failure to follow this warning could result in personal injury or death.

Before installing or servicing system, always turn off main power to system. There may be more than one disconnect switch. Tag disconnect switch with a suitable warning label. Turn off accessory heater power if applicable.

### **CAUTION**

#### UNIT OR PROPERTY DAMAGE HAZARD

Failure to follow this caution may result in product or property damage.

This coil contains Nitrogen precharge of 15 PSI. Release of this pressure through the center of the rubber plugs is required before removing the plugs.

### **CAUTION**

#### CUT HAZARD

Failure to follow this caution may result in personal injury.

Sheet metal parts may have sharp edges or burrs. Use care and wear appropriate protective clothing and gloves when handling parts.

**IMPORTANT:** Nitrogen can leak out through the hole that the needle pierced in the plugs. This does not indicate a leaking coil nor warrant return of the coil.

## INTRODUCTION

---

Use this instruction manual to install indoor coils on upflow or downflow furnaces. (See Figure 1) Do not install coil in horizontal position. ENA4X coils have factory-installed

thermostatic expansion valves (TXVs) and are used with R-410A refrigerant systems.

## INSTALLATION

---

These units can be installed in either upflow or downflow configurations. Before installation, there are several performance requirements that must be considered because poor installation can negatively alter performance. This section will briefly discuss those factors.

### TXV

A thermal expansion valve is utilized in this coil design to optimize performance and comfort throughout the entire operating range of the system. Special attention needs to be taken to the TXV when installing the coil

- Do not overheat valve. Temperatures that exceed 212°F (100°C) can harm valve performance. Use a wet cloth or heat sink when brazing.
- Place filter dryer near ID unit to reduce the risk of debris clogging the valve.
- Make sure TXV bulb is securely fastened and wrapped in the indentation on heater tube.

ENA4X coils have a factory-installed hard-shutoff TXV designed only for use with R-410A refrigerant. Use only with outdoor units designed for R-410A.

**NOTE:** All TXVs have preset superheat settings and are not field-adjustable.

### Airflow

Airflow amount and distribution are vital to adequate system performance. Problems that can be experienced with incorrect airflow include:

- low system performance
- restricted TXV
- frosted coil
- poor humidity control
- water blow-off

When attaching the coil and building the plenum, pay special attention to the effect these details will have on airflow. After system start-up, check the cfm to insure that it is correct. (Generally, the cfm should be 350 to 400 cfm/ton during normal cooling operation.)

### Condensate Management

With proper installation, these coils will manage the condensate without blow-off into the duct work. See detailed instructions for more info.

## Procedure 1 — Inspect Equipment

File claim with shipper if equipment is damaged.

The following parts are included with this coil (See Figure 1), depending on your application different components will be required.

COMPONENT	QUANTITY
Support Rails	2
Collar	1
Header Plate	1
Grommets	2
Extension Air Baffles	2

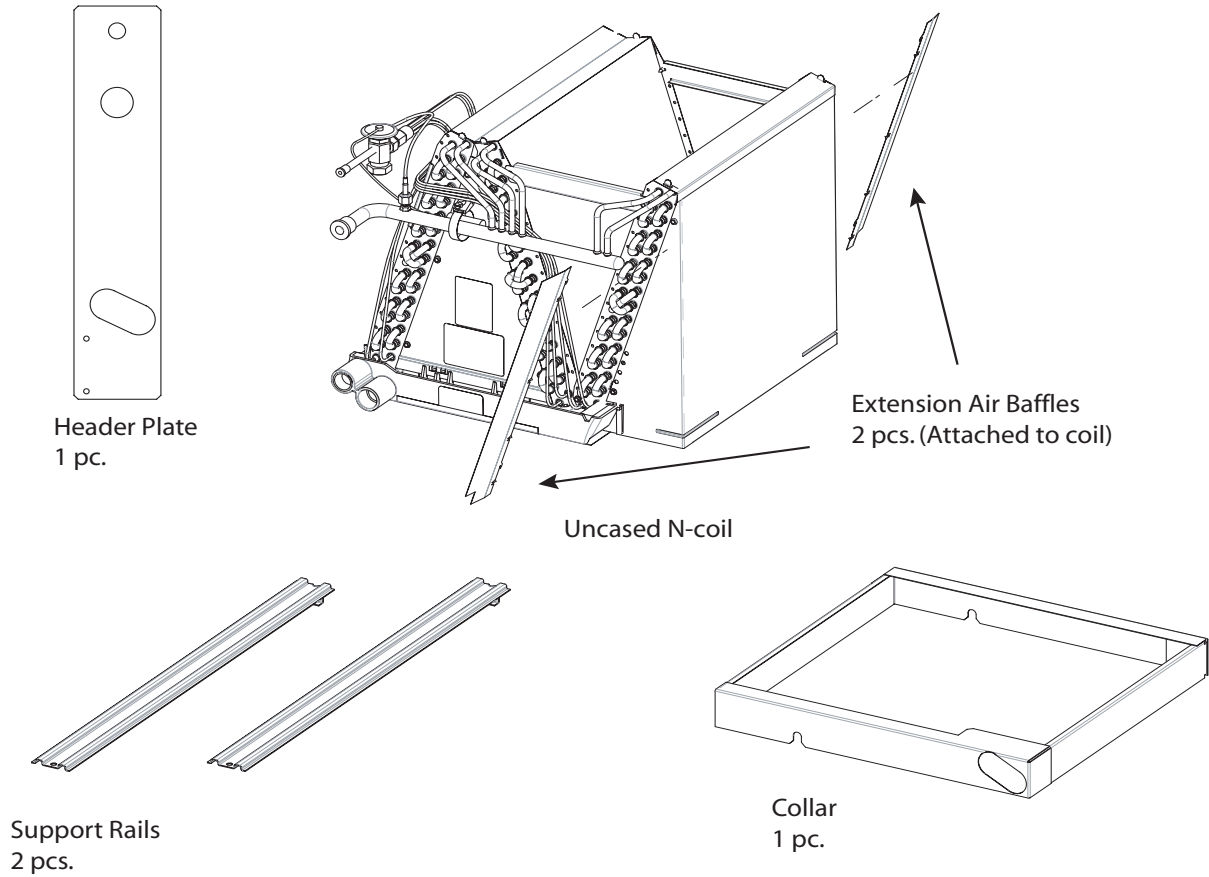
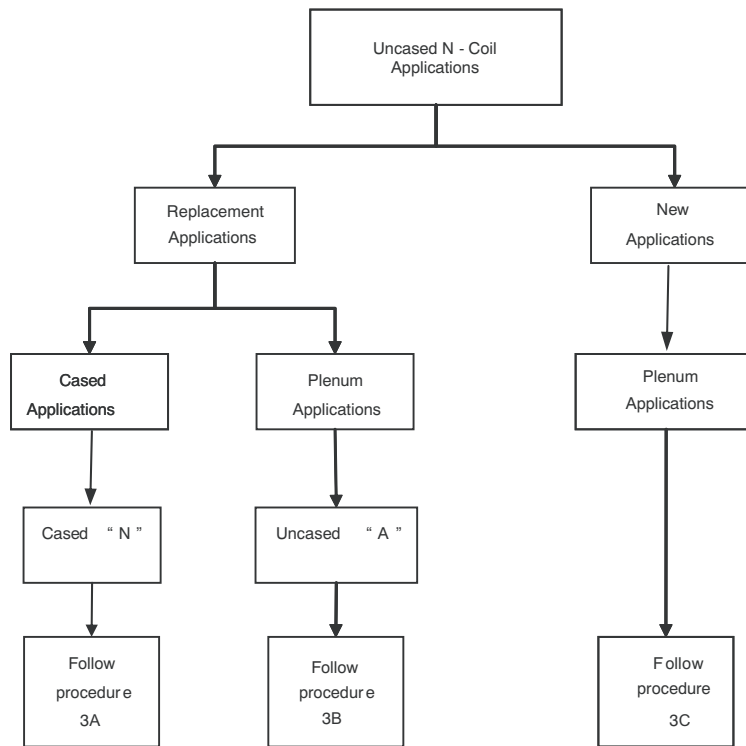

**Figure 1 – Uncased N-Coil Components**

A06362

## Procedure 2 — Select Installation

Select and follow the installation instruction that best suits your needs:



**Figure 2 – Uncased N-Coil Applications**

A06363

Table 1	ENA4X Uncased Coil Information				
	TONNAGE	COLLAR SIZE inches (mm)		COIL CONNECTION TUBE SIZE inches (mm)	
		Depth	Width	Liquid	Suction
ENA4X18(C,T)14A	1–1/2	19–3/8 (492)	12–7/8 (327)	3/8 (10)	5/8 (16)
ENA4X19(C,T)17A	1–1/2	19–3/8 (492)	16–1/4 (413)	3/8 (10)	3/4 (19)
ENA4X24(C,T)14A	2	19–3/8 (492)	12–7/8 (327)	3/8 (10)	5/8 (16)
ENA4X24(C,T)17A	2	19–3/8 (492)	16–1/4 (413)	3/8 (10)	5/8 (16)
ENA4X30(C,T)14A	2–1/2	19–3/8 (492)	12–7/8 (327)	3/8 (10)	3/4 (19)
ENA4X30(C,T)17A	2–1/2	19–3/8 (492)	16–1/4 (413)	3/8 (10)	3/4 (19)
ENA4X31(C,T)17A	2–1/2	19–3/8 (492)	16–1/4 (413)	3/8 (10)	3/4 (19)
ENA4X36(C,T)17A	3	19–3/8 (492)	16–1/4 (413)	3/8 (10)	3/4 (19)
ENA4X36(C,T)21A	3	19–3/8 (492)	19–5/8 (498)	3/8 (10)	3/4 (19)
ENA4X37(C,T)17A	3	19–3/8 (492)	16–1/4 (413)	3/8 (10)	7/8 (22)
ENA4X42(C,T)21A	3–1/2	19–3/8 (492)	19–5/8 (498)	3/8 (10)	7/8 (22)
ENA4X43(C,T)24A	3–1/2	19–3/8 (492)	23–1/8 (587)	3/8 (10)	7/8 (22)
ENA4X48(C,T)21A	4	19–3/8 (492)	19–5/8 (498)	3/8 (10)	7/8 (22)
ENA4X48(C,T)24A	4	19–3/8 (492)	23–1/8 (587)	3/8 (10)	7/8 (22)
ENA4X60(C,T)24A	5	19–3/8 (492)	23–1/8 (587)	3/8 (10)	7/8 (22)
ENA4X61(C,T)24A	5	19–3/8 (492)	23–1/8 (587)	3/8 (10)	7/8 (22)

See Table 1 for dimensions and overhang options. Note instructions for placement of coil casing on furnace.

For **replacement** applications using an existing cased N-coil assembly follow Procedure 3A.

For **replacement** applications using an existing uncased A-coil plenum installation follow Procedure 3B.

For **new** applications using a field-fabricated plenum installation follow Procedure 3C.

### Procedure 3 — Installation of Evaporator Coil

## ⚠ CAUTION

### CUT HAZARD

Failure to follow this caution may result in personal injury.

Sheet metal parts may have sharp edges or burrs. Use care and wear appropriate protective clothing and gloves when handling parts.

### NOTE: Upflow and downflow applications using an existing A-coil casing is not approved:

N-coils will not properly fit into A-Coil casings and retrofitting is not approved. Only replace an uncased N-coil in a N-coil casing.

### 3A. Upflow and downflow applications using an existing N-coil casing.

1. Remove and keep front access and tubing header panel.
2. Remove old N-coil from casing and discard coil.
3. Slide new N-coil into casing.
4. Cut holes for liquid, suction and drain connections in the existing header panel. Use **new header plate** supplied with coil as template to locate holes. Align header plate to the header panel using the upper hole as indicated in Figure 3.

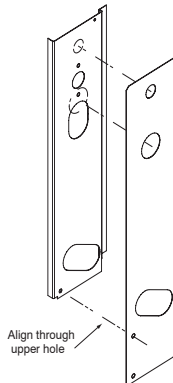

A06292

### Figure 3 – Use Header Plate as Template

5. Slide header panel over tubing and condensate pan connections and secure fitting panel to casing.
6. Cut bottom portion of **header plate**, just below the drain connections, see Figure 4.

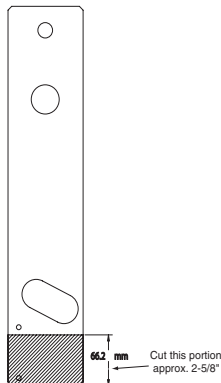

A06293

### Figure 4 – Header Plate Cut-Off

7. Slide **header plate** and **grommets** over tubing and condensate pan connections and secure it to the header panel to cover up oversized and additional holes. This will provide an airtight seal and better installation presentation (See Figure 5).
8. Reinstall and secure front access panel to casing.

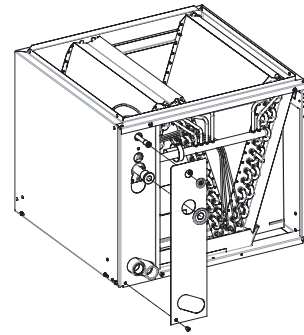

A06364

### Figure 5 – Uncased N-Coil & Cased N-coil Casing

**3B. Upflow and downflow replacement applications using an existing plenum with an uncased A-coil.**

1. Cut front access of plenum so that old A-coil can be removed.
2. Remove old A-coil from plenum and discard coil.
3. Place **collar** over furnace flanges inside of plenum (See Figure 1).

**IMPORTANT:** Insure that **collar** is level for proper drainage.

4. Remove front and rear **extension air baffles** from new N-coil.
5. Slide new N-coil into plenum.
6. Cut holes for liquid, suction and drain connections in the existing field-fabricated front access panel of plenum on fabricated new panel. Use **header plate** supplied with coil as template to locate holes.
7. Slide **header plate** and **grommets** over tubing and condensate pan connections and secure it to the plenum front access to cover up oversized and additional holes. This will provide an airtight seal and better installation presentation.
8. Seal all joints to create air tight seal using locally approved materials.

**3C. Upflow and downflow applications using a new field fabricated plenum installation.**

For uncased N-coil ENA4X width and depth dimensions See Table 1. Fabricate plenum accordingly.

1. Mount **collar** directly on furnace flanges to support the coil.
2. Remove front and rear extension **air baffles** from new N-coil.
3. Slide new N-coil into plenum opening.
4. Cut holes for liquid, suction connections in field-fabricated front plenum panel. Use **header plate** supplied as template to locate holes.
5. Cover plenum opening with field-fabricated front plenum panel.
6. Slide **header plate** and **grommets** over tubing and condensate pan connections and secure it to the field fabricated front plenum panel to cover up oversized holes. This will provide an airtight seal and better installation presentation.
7. Seal all joints to create air tight seal using locally approved materials.

**IMPORTANT:** Locate caution label stapled to installation instructions. Attach to right side of plenum or accessory casing (See Figure 6).



A06285

**Figure 6 – Plenum Caution Label**

**NOTE:** The uncased N-coil features an enclosure to direct airflow through the third coil slab.

**NOTE:** If coil is not being installed in the standard orientation (front of coil matching front of furnace) then coil must be raised 2-1/4 inches (57mm) above furnace.

**NOTE:** Installing coils rotated 90° from the front of the furnace, in upflow or downflow applications, can cause water blow-off or coil freeze-up due to the concentration of air on one slab of the coil or lack of air to a slab in the coil. It is recommended that on this type of application, a field-supplied adapter be placed between the coil and furnace to allow air to distribute properly between all slabs of the coil.

## Procedure 4 — Connect Refrigerant Piping

Use accessory tubing package or field-supplied tubing of refrigerant grade. Suction tube must be insulated. Do not use damaged, dirty, or contaminated tubing because it may plug refrigerant flow-control device. ALWAYS evacuate the coil and field-supplied tubing before opening outdoor unit service valves.

## Procedure 5 — Connect Refrigerant Liquid and Suction Lines

For matched and mismatched systems, use line sizes recommended in outdoor unit Installation Instructions.

The coil can be connected to outdoor units using accessory tubing packages or field-supplied tubing of refrigerant grade. Always evacuate tubing and reclaim refrigerant when making connections or flaring tubing. Leak check connections before insulating entire suction line.

### SUCTION LINE

Suction line is designed for field sweat connection. Line is plugged to keep out moisture and dirt. Remove these plugs only when ready to make connection.

See Figure 1 for coil connection tube size.

## ⚠ CAUTION

### PRODUCT DAMAGE HAZARD

Failure to follow this caution may result in product or property damage.

To avoid damage to the refrigerant control device while brazing, wrap tubing or fittings with a heat-sinking material such as a wet cloth.

1. Remove header plate.
2. Remove rubber plugs from coil stubs using a pulling and twisting motion. Hold coil stubs steady to avoid bending or distorting.
3. Wrap TXV and nearby tubing with a heat sinking material such as a wet cloth.
4. Fit refrigerant lines into coil stubs. Wrap a heat sinking material such as a wet cloth behind braze joints.
5. Braze using a Sil-Fos or Phos-copper alloy.
6. After brazing, allow joints to cool. Slide tubing plate with rubber grommets over joints. Position tubing at center of each grommet to ensure an air seal around the tube.

### REFRIGERANT METERING DEVICE

ENA4X coils have a factory-installed hard-shutoff TXV designed only for use with R-410A refrigerant. Use only with outdoor units designed for R-410A.

**NOTE:** ALL TXVs HAVE PRESET SUPERHEAT SETTINGS AND ARE FIELD **NON-ADJUSTABLE**.

## Procedure 6 — Condensate Drain Line Connection

## ⚠ CAUTION

### PROPERTY DAMAGE HAZARD

Failure to follow this caution may result in property damage.

When installing over a finished ceiling and/or living area, install a field-fabricated secondary condensate pan under the entire unit.

The coil is designed to dispose of accumulated water through built-in condensate drain fittings. It is recommended that PVC fittings be used on the condensate pan. Do not over-tighten. Finger tighten plus 1-1/2 turns. Be sure to install plastic plug in unused condensate drain fitting. Two 3/4 (19mm) inch female threaded pipe connections are provided in each coil condensate pan.

A trap is not necessary on the condensate line. Consult local codes for additional restrictions or precautions. If local codes require a trap then the following guidelines are suggested to assure proper drainage. Install a trap in condensate line of coil as close to the coil as possible. Make trap at least 3 inches (76 mm) deep and no higher than the bottom of unit condensate drain opening (See Figure 7). Pitch condensate line 1 inch (25.4 mm) for every 10 feet (3m) of length to an open drain or sump. Make sure that the outlet of each trap is below its connection to condensate pan to prevent condensate from overflowing the drain pan. Prime all traps, test for leaks, and insulate traps and lines if located above a living area.

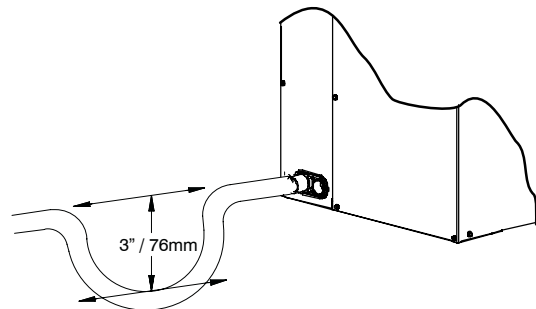

Figure 7 – Condensate Trap

A08067X

**NOTE:** If unit is located in or above a living space, where damage may result from condensate overflow, a field-supplied, external condensate pan should be installed underneath the entire unit, and a secondary condensate line (with appropriate trap) should be run from the unit into the pan. Any condensate in this external condensate pan should be drained to a noticeable place. As an alternative to using an external condensate pan, some localities may allow the running of a separate 3/4 inch (19 mm) condensate line (with appropriate trap) per local code to a place where the condensate will be noticeable. The owner of the structure must be informed that when condensate flows from secondary drain or external condensate pan, the unit requires servicing or water damage will occur. To further protect against water damage, install a float switch to shut the unit off if the water in the secondary pan gets too high.

**NOTE:** To avoid drainage problems, test the primary drain line by slowly pouring water into the pan. Check piping for leaks and proper condensate drainage. Using the secondary drain as explained in the previous note provides further protection against overflow due to a clogged primary drain.

**NOTE:** In applications where return air humidity levels stay at 70% or above for a prolonged period of time, condensation can form on the bottom of pan and drip.

**WASTE LINE CONNECTION**

If the condensate line is to be connected to a waste (sewer) line, an open trap must be installed ahead of the waste line to prevent escape of sewer gases (See Figure 8).

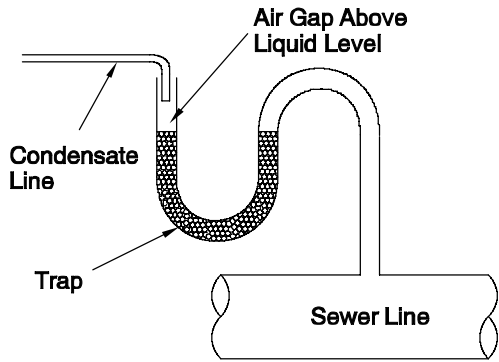

A10216

**Figure 8 – Condensate Drain to Waste Line**

 <b>WARNING</b>
<p><b>EXPLOSION HAZARD</b></p> <p>Failure to follow this warning could result in personal injury or death.</p> <p>Provide trap with air gap in drain line when connecting to waste (sewer) line.</p>

**Procedure 7 — Humidifier Application**

When installing a humidifier in a system which contains an N-coil, consideration must be given to location of coil slabs. (See Figure 9)

1. Care must be taken to prevent damage of N-coil when attaching humidifier to coil casing or plenum.
2. These models are shipped with a Caution Label (see Figure 6) to be applied to plenum to indicate slab location. When these coils are removed from their casing and applied directly into the plenum, affix this Caution Label to the right side of the plenum enclosure. This is needed only in cases where the humidifier is not installed with original equipment. Label will alert future service and installation technicians about coil slab location.
3. Ensure that humidifier has adequate airflow.

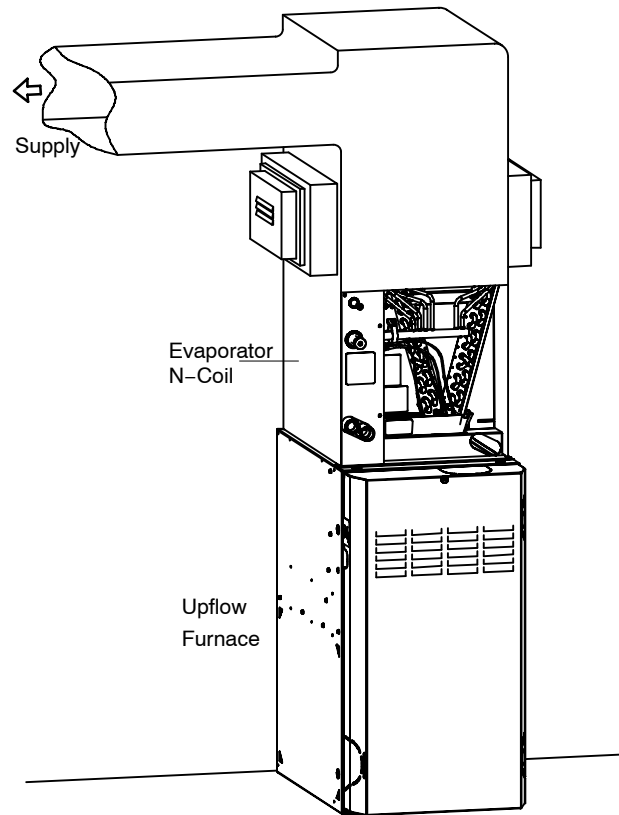

A06016

**Figure 9 – Installation of Humidifier in System with N-Coil**



## COIL MODEL NUMBER IDENTIFICATION GUIDE

Digit Position	1	2	3	4	5	6,7	8	9,10	11	12
	<b>E</b>	<b>N</b>	<b>A</b>	<b>4</b>	<b>X</b>	<b>18</b>	<b>C</b>	<b>14</b>	<b>A</b>	<b>1</b>
E = Evaporator										
B = Builder										
D = Standard										
N = N Coil		<b>TYPE</b>								
A = Uncased										
D = Cased Upflow/Downflow										
M = Cased Multiposition (Upflow/Downflow/Horizontal)										
W = Cased Upflow/Downflow for narrower furnaces										
H = Cased Horizontal		<b>INSTALLATION</b>								
4 = Environmentally Sound R-410A				<b>REFRIGERANT</b>						
P = Piston										
X = TXV				<b>METERING DEVICE</b>						
18 = 18,000 BTUH = 1½ tons										
19 = 18,000 BTUH = 1½ tons										
24 = 24,000 BTUH = 2 tons										
30 = 30,000 BTUH = 2½ tons										
31 = 30,000 BTUH = 2½ tons										
36 = 36,000 BTUH = 3 tons										
37 = 36,000 BTUH = 3 tons										
42 = 42,000 BTUH = 3½ tons										
43 = 42,000 BTUH = 3½ tons										
48 = 48,000 BTUH = 4 tons										
60 = 60,000 BTUH = 5 tons										
61 = 60,000 BTUH = 5 tons				<b>NOMINAL CAPACITY</b>						
C = Plain Copper										
L = Aluminum										
T = Tin Coated Copper				<b>HAIRPIN MATERIAL</b>						
14 = 14.5"										
17 = 17.5"										
21 = 21"										
24 = 24.5"										
BB = 15.5"										
FF = 19.1"										
JJ = 22.8"										
LL = 24.5"				<b>WIDTH</b>						
Sales Digit (Major Revision)										
Engineering Digit (Minor Revision)										