

H705A Solid State Enthalpy Controller

PRODUCT DATA

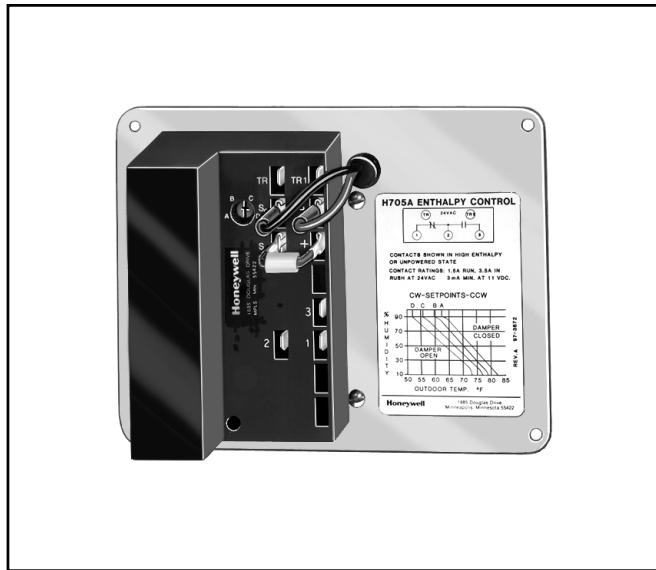

APPLICATION

The H705A Solid State Enthalpy Controller maximizes the use of free outdoor air in place of the first stage of cooling in heating, ventilating and air conditioning (HVAC) economizer systems.

FEATURES

- Provides accurate solid state enthalpy changeover control in a corrosion-resistant, plate-mounted package.
- Mounting plate matches plate-mounted H205A Enthalpy Controller for easy replacement. Also matches electromechanical Barber Colman THC-2 Enthalpy Controller.
- Controls operation of the economizer outdoor air damper to provide free cooling on a signal from the cooling thermostat.
- Can be mounted in any position inside an economizer unit.
- One model can be used for both electronic and electromechanical systems.
- Provides greater economizer savings when optional differential changeover control is used with a C7400A Sensor mounted in the return air duct.
- Enthalpy setpoint (A,B,C,D) located on H705A Solid State Enthalpy Controller is used to select combination of air temperature and humidity that is suitable for free cooling.
- Compact size and lightweight construction provide easy mounting in HVAC rooftop unit.
- Quick-connect terminals reduce installation time.

Contents

Application	1
Features	1
Specifications	2
Ordering Information	2
Installation	3
Operation	8
Checkout and Troubleshooting	9



SPECIFICATIONS

Model:

H705A Solid State Enthalpy Controller with mounting plate and 1/4 in. (6 mm) quick-connect terminals. For use with both electronic and electromechanical controls.

Humidity Sensing Element:

Capacitive film.

Temperature Sensing Element:

Thermistor.

Switching Action:

Single pole double throw (spdt) 1/4 in. (6 mm) quick-connect terminals. Terminals 2 and 1 make with enthalpy increase above setpoint. Terminals 2 and 3 make with enthalpy decrease below setpoint.

Electrical Ratings:

Input Voltage: 24 Vac, 50/60 Hz.

Power Consumption: 5.5 VA.

Relay Contact Ratings at 24 Vac: 1.5A run, 3.5A inrush.

Dimensions:

See Fig. 1.

Temperature Ratings:

Operating Ambient: -25°F to +125°F (-32°C to +52°C).

Approvals:

Underwriters Laboratories Inc.: Flammability Rating: UL94V-0.

Accessories:

4074EJM Accessory Kit (620 ohm resistor, jumper, 1.2K ohm checkout resistor).

C7400A Solid State Enthalpy Sensor.

S963B1128 Minimum Position Potentiometer.

ORDERING INFORMATION

When purchasing replacement and modernization products from your TRADELINE® wholesaler or distributor, refer to the TRADELINE® Catalog or price sheets for complete ordering number.

If you have additional questions, need further information, or would like to comment on our products or services, please write or phone:

1. Your local Home and Building Control Sales Office (check white pages of your phone directory).
2. Home and Building Control Customer Relations
Honeywell, 1885 Douglas Drive North
Minneapolis, Minnesota 55422-4386

In Canada—Honeywell Limited/Honeywell Limitée, 35 Dynamic Drive, Scarborough, Ontario M1V 4Z9.

International Sales and Service Offices in all principal cities of the world. Manufacturing in Australia, Canada, Finland, France, Germany, Japan, Mexico, Netherlands, Spain, Taiwan, United Kingdom, U.S.A.

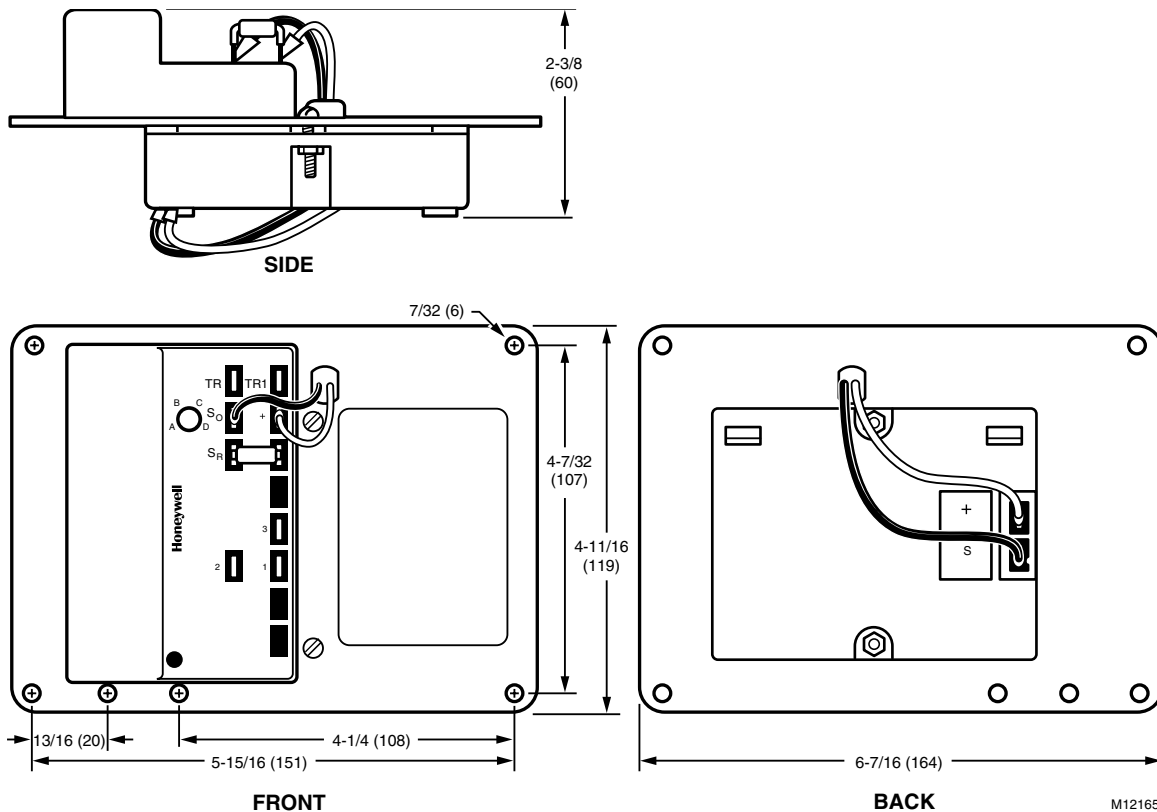

Fig. 1. Approximate dimensions of H705A Solid State Enthalpy Controller with mounting plate in in. (mm).

INSTALLATION

When Installing this Product...

1. Read these instructions carefully. Failure to follow them could damage the product or cause a hazardous condition.
2. Check the ratings given in these instructions and on the product to make sure the product is suitable for your application.
3. Installer must be a trained, experienced service technician.
4. After installation is complete, check out product operation as provided in these instructions.

CAUTION

CAN CAUSE ELECTRICAL SHOCK OR EQUIPMENT DAMAGE.

Disconnect power supply before installation.

IMPORTANT

Make sure the enthalpy sensor is not exposed to rain, snow, or direct sunlight when selecting the location.

Location

The H705A Solid State Enthalpy Controller can be mounted in any position inside the outdoor air intake hood where it is exposed to freely circulating outside air and is protected from rain or direct sunlight. The sensors perform best with an air flow of at least 500 feet per minute.

For differential enthalpy control, install a C7400A Sensor in the return air duct up to 200 feet from the controller. Use 18, 20 or 22 AWG wire for connecting the sensor to the controller.

Mounting

To replace H205A (less mounting plate):

- ❶ Turn off power to H205A.
- ❷ Disconnect H205A wires.
- ❸ Remove H205A.
- ❹ Install H705A using L-shaped bracket (if required). See Fig. 2.

Mount the H705A in an area with adequate outdoor airflow and protected from rain or direct sunlight.

To replace H205A (with mounting plate):

- ❶ Turn off power to H205A.
- ❷ Disconnect H205A wires.

- ❸ Remove screws from mounting plate and slide H205A clear of sheet metal.
- ❹ If wiring, housing and knob are in a position not exposed to weather, replace with H705A using existing cutout and screw holes.
- ❺ If unit is exposed to weather, relocate the H705A inside the outdoor air housing. Use the existing H205A wiring compartment for connection of additional wiring, if necessary.

The L-shaped bracket can be used in a variety of ways to aid installation of the H705A. See Fig. 2 for L-shaped bracket dimensions and suggested mounting orientation.

Wiring



CAUTION

CAN CAUSE ELECTRICAL SHOCK OR EQUIPMENT DAMAGE.

Disconnect power supply before wiring.

All wiring must comply with applicable local codes and ordinances. Follow wiring information furnished by the HVAC equipment manufacturer or refer to Fig. 3 through 6 for typical wiring hookups.

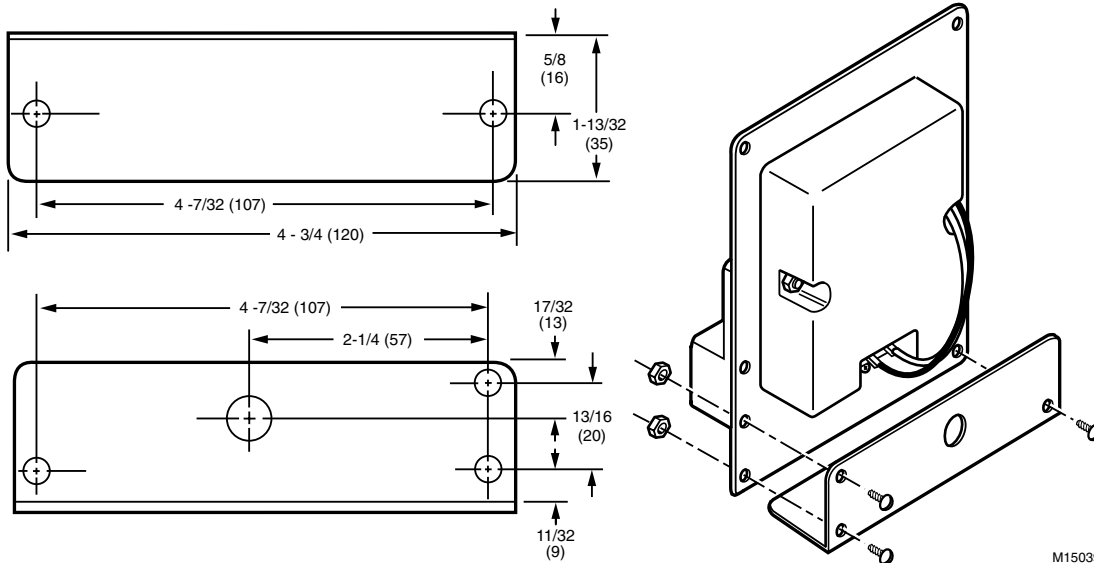
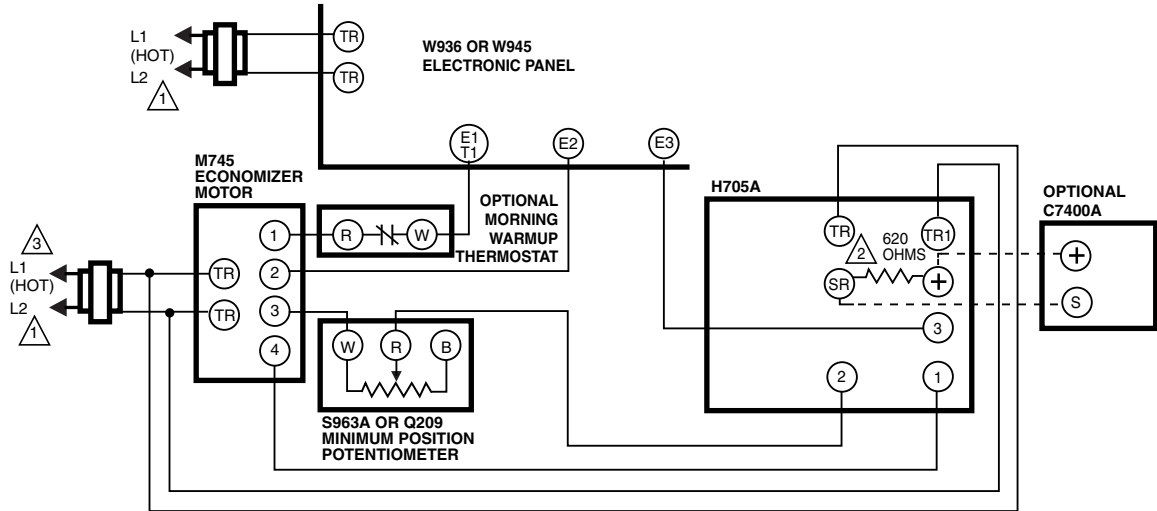

Fig. 2. Approximate dimensions of L-shaped bracket in in. (mm).



- 1 PROVIDE DISCONNECT MEANS AND OVERLOAD PROTECTION AS REQUIRED.
- 2 FACTORY INSTALLED 620 OHM, 1 WATT, 5% RESISTOR SHOULD BE REMOVED ONLY IF A C7400A SENSOR IS ADDED TO SR AND + FOR DIFFERENTIAL ENTHALPHY.
- 3 ENSURE THAT EQUIPMENT TRANSFORMER IS SIZED TO HANDLE THE EXTRA LOAD OF THE ECONOMIZER AND ACTUATOR.

M15037

Fig. 3. H705A used in electronic system.

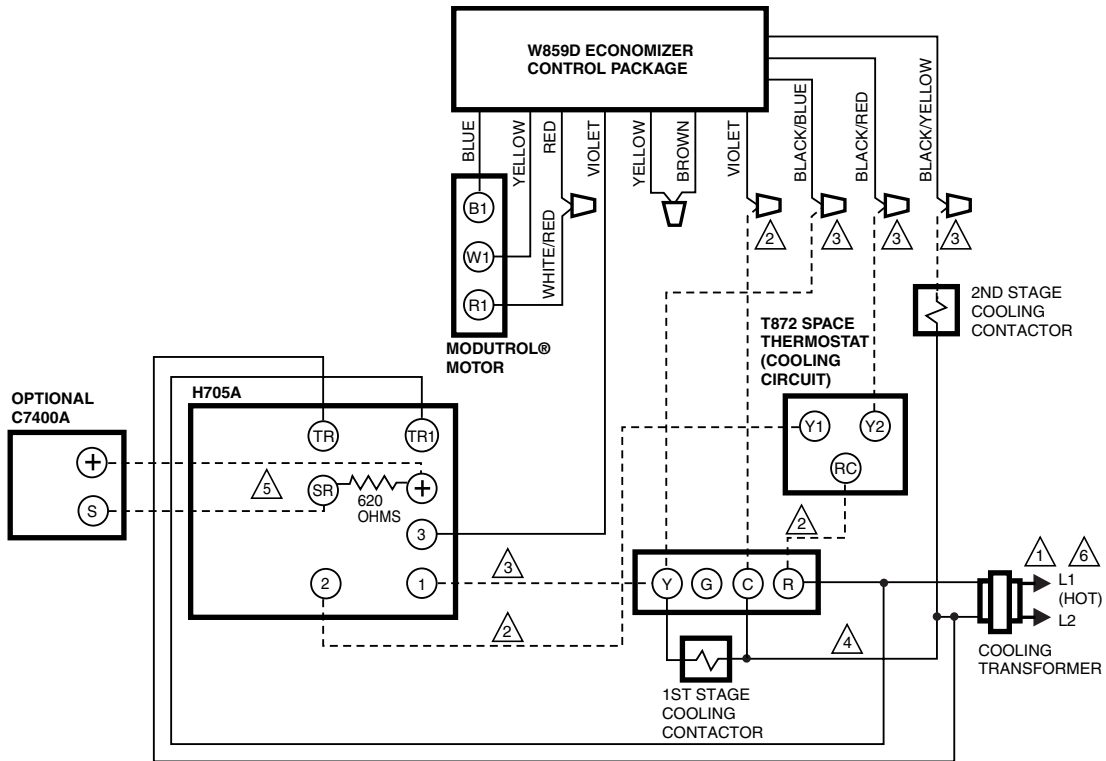

- 1 PROVIDE DISCONNECT MEANS AND OVERLOAD PROTECTION AS REQUIRED.
- 2 FIELD CONTROL WIRING REQUIRED TO INTEGRATE ECONOMIZER INTO UNIT.
- 3 FIELD WIRING REQUIRED TO PROVIDE ECONOMIZER AND MECHANICAL COOLING OPERATION IN EXISTING INSTALLATION.
- 4 ROOFTOP TERMINAL STRIP IS PART OF AIR CONDITIONING UNIT.
- 5 FACTORY-INSTALLED 620 OHM, 1 WATT, 5% RESISTOR SHOULD BE REMOVED ONLY IF A C7400A SENSOR IS ADDED TO SR AND + FOR DIFFERENTIAL ENTHALPHY.
- 6 ENSURE THAT EQUIPMENT TRANSFORMER IS SIZED TO HANDLE THE EXTRA LOAD OF THE ECONOMIZER AND ACTUATOR.

M12162

Fig. 4. H705A used in electromechanical system.

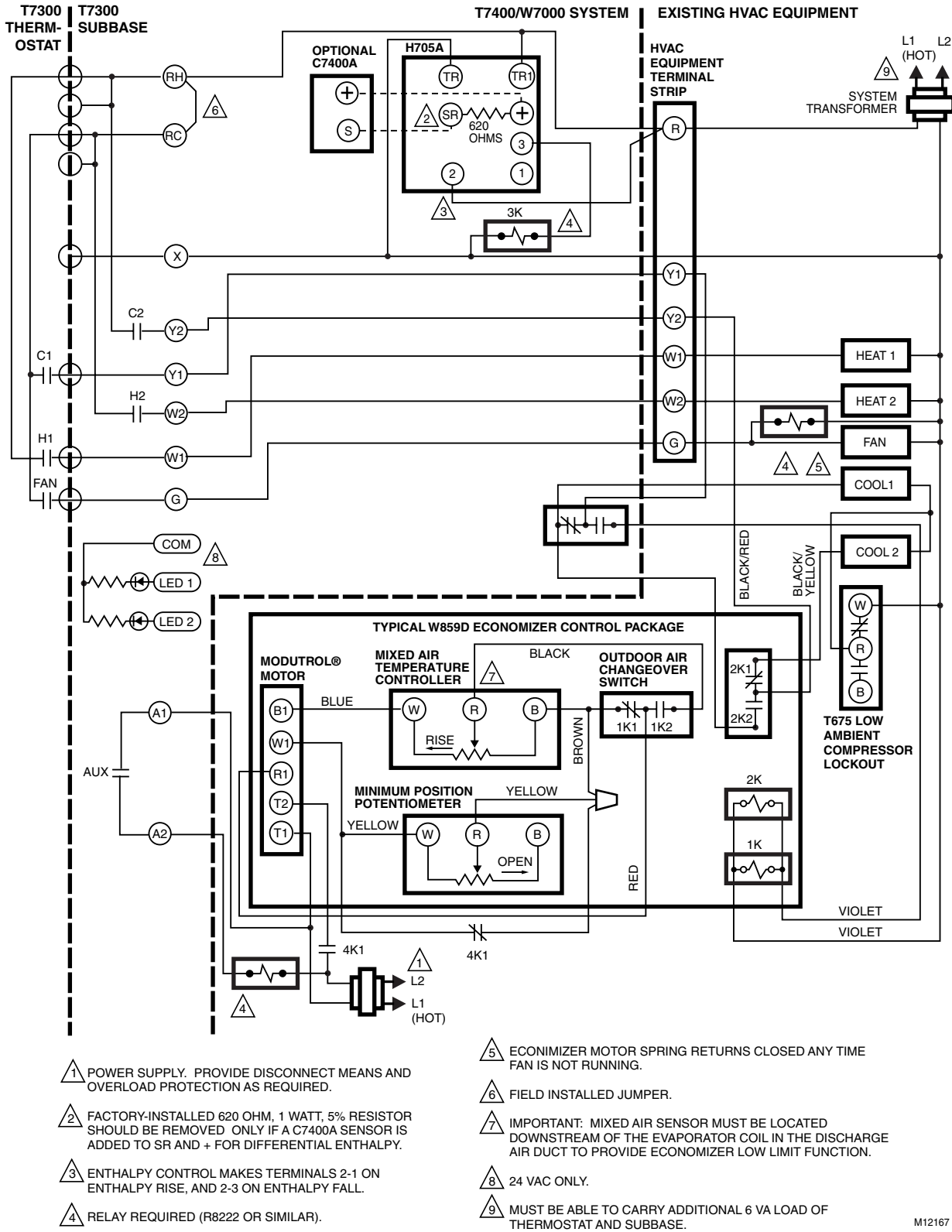

M12167

Fig. 5. T7300/Q7300 using W859D Economizer Package with H705A in two-stage heating/two-stage cooling system, defeating economizer minimum position during unoccupied periods.

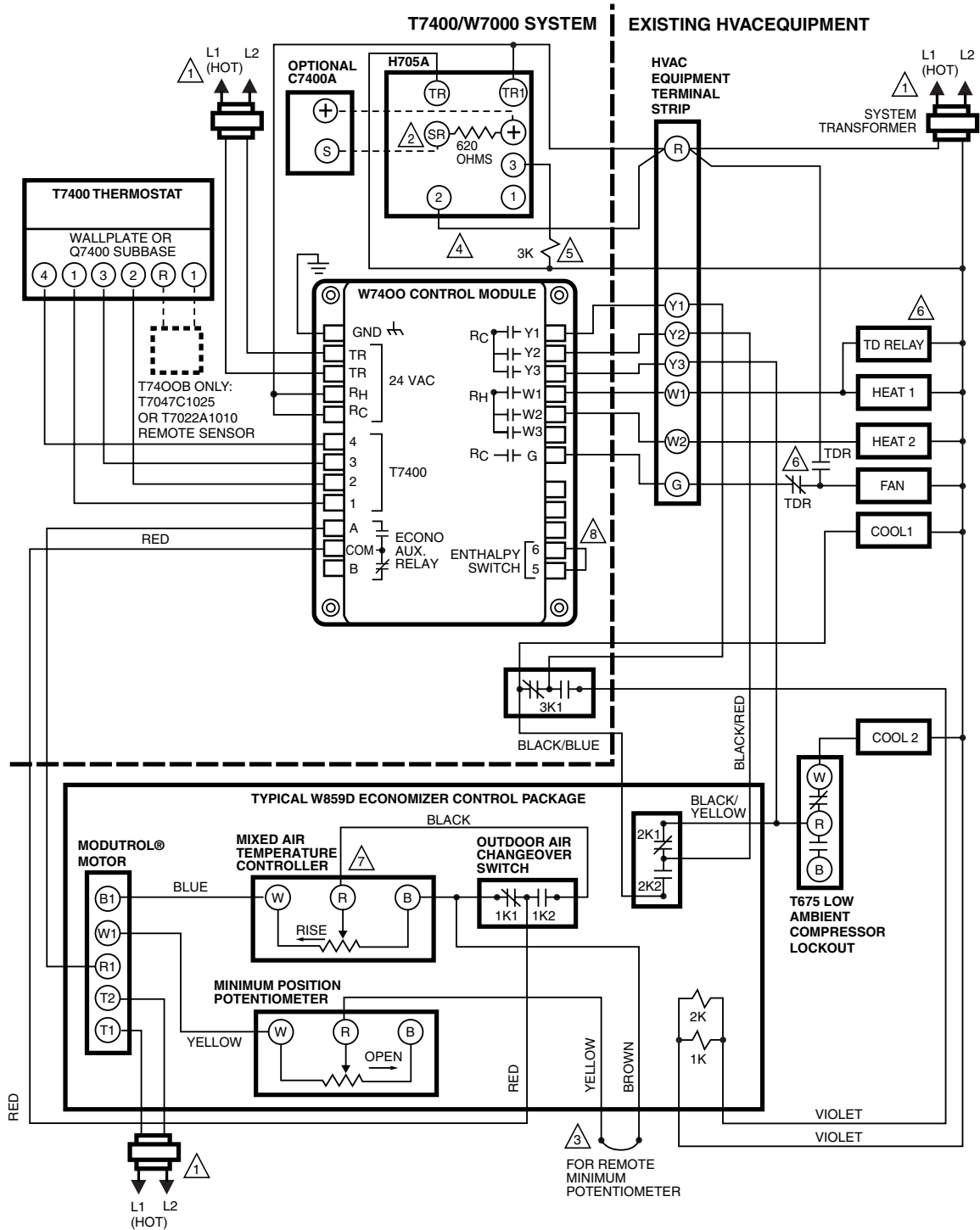

- 1 POWER SUPPLY. PROVIDE DISCONNECT MEANS AND OVERLOAD PROTECTION AS REQUIRED.
- 2 FACTORY-INSTALLED 620 OHM, 1 WATT, 5% RESISTOR SHOULD BE REMOVED ONLY IF A C7400A SENSOR IS ADDED TO SR AND + FOR DIFFERENTIAL ENTHALPY.
- 3 YELLOW AND BROWN LEADS ARE SHORTED TOGETHER WHEN SHIPPED. LEAVE SHORTED IF OPTIONAL FUNCTIONS ARE NOT USED.
- 4 ENTHALPY CONTROL MAKES TERMINALS 2-1 ON ENTHALPY RISE, AND 2-3 ON ENTHALPY FALL.
- 5 PILOT DUTY RELAY REQUIRED (R8222N OR SIMILAR).
- 6 THIS CONTROL IS AN EXISTING DEVICE, WHICH MAY BE A TIME DELAY RELAY (TDR) OR L4604 (OR SIMILAR FAN CONTROL) IN SOME SYSTEMS.
- 7 IMPORTANT: MIXED AIR SENSOR MUST BE LOCATED DOWNSTREAM OF THE EVAPORATOR COIL IN THE DISCHARGE AIR DUCT TO PROVIDE ECONOMIZER LOW LIMIT FUNCTION.
- 8 JUMPER TERMINALS 5 AND 6.

M12166

Fig. 6. H705A used with T7400C and W7400C with separate transformer in two-stage heating/three-stage cooling system with first stage dedicated to economizer setpoint, and either electromechanical economizer or mechanical cooling first stage.

Connect H705A terminals TR and TR1 to a 24 Vac power source with 5.5 VA excess capacity. The factory-installed 620 ohm resistor between terminals SR and + must remain in place unless a return air duct mounted C7400A Sensor is installed for differential enthalpy control.

For differential enthalpy control:

- ❶ Mount a C7400A Sensor, in any position, in the return air duct where it will not interfere with damper blade movement or be exposed to mixed air.
- ❷ Disconnect power from H705A terminals TR and TR1.
- ❸ Remove 620 ohm resistor from between terminals SR and +.
- ❹ Connect S and + terminals of C7400A Sensor to terminals SR and + of H705A.

When replacing an H705, the wires previously connected to the H205A should be reconnected to the H705A as follows:

- ❶ Connect red wire to H705A terminal 2.
- ❷ Connect yellow wire to H705A terminal 1.
- ❸ Connect blue wire to H705A terminal 3.

OPERATION

Enthalpy Changeover Setpoint

With single enthalpy control, the A,B,C,D enthalpy setpoint is used to adjust the enthalpy changeover characteristic as shown in Fig. 7. The A setting provides the greatest energy savings. The factory-installed 620 ohm resistor must be in place across terminals SR and +.

Differential Enthalpy Changeover Setting

To operate in the differential mode:

- ❶ Remove the 620 ohm resistor from H705A terminals SR and +.
- ❷ Connect a C7400A Sensor to H705A terminals SR and +.
- ❸ Turn the enthalpy setpoint potentiometer fully clockwise  to the D setting.

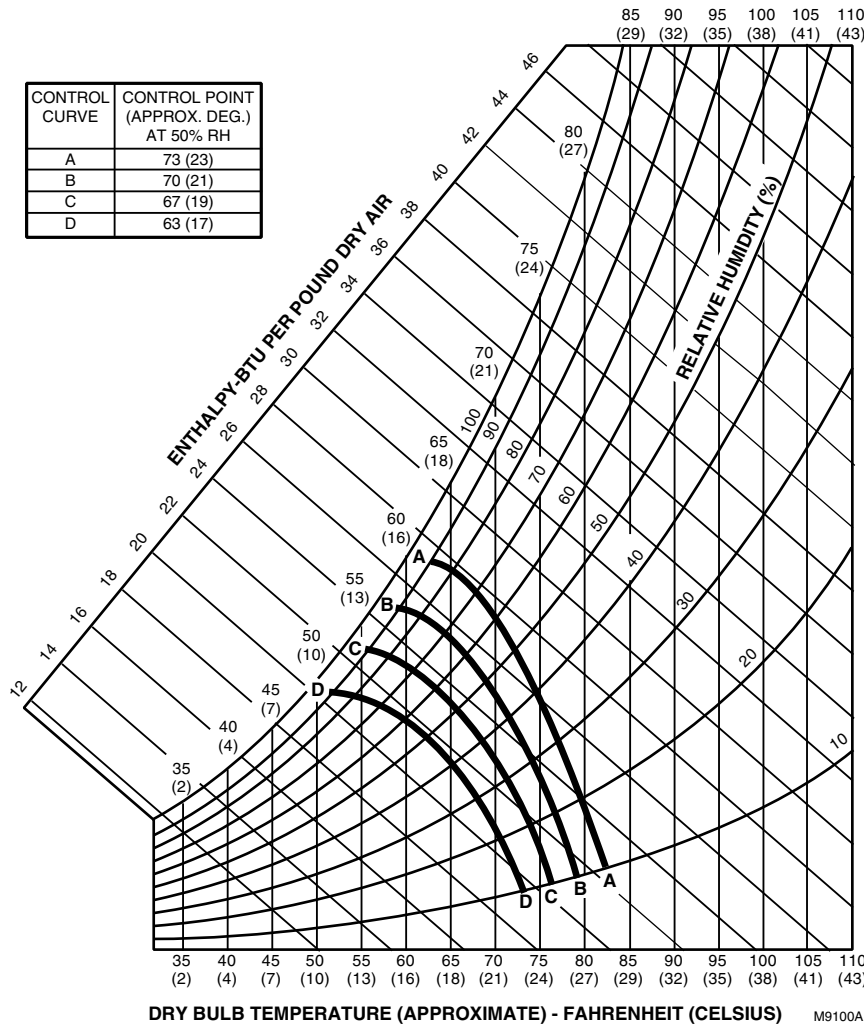

Fig. 7. H705A performance characteristics for enthalpy changeover settings A,B,C, and D.

The economizer makes sure that the lowest enthalpy air is used when cooling. If the outdoor air has lower enthalpy than return air, the outdoor air damper opens to bring in outdoor air for free cooling.

Integrated Economizer System

Operation: Single Enthalpy

The purpose of an economizer is to use outdoor air for cooling, whenever possible, to reduce compressor operation. The H705A economizer system, when wired as shown in Fig. 3 through 6, responds to a signal from the cooling thermostat. This H705A system utilizes a solid state enthalpy changeover sensor. It responds to both dry bulb temperature and humidity, allowing the use of outdoor air at higher temperature for free cooling when the humidity is low.

The economizer functions as a true first stage of cooling and provides maximum fuel economy during the cooling cycle. The economizer is automatically locked out during heating and holds the outdoor air damper at the minimum position setting.

On a call for cooling by the space thermostat, the system operates as follows:

When the enthalpy of the outdoor air is below the setpoint, the outdoor air damper is proportioned open (and return air damper is proportioned closed) to maintain between 50°F and 56°F (10°C and 13°C) at the mixed/discharge air sensor. During economizer operation, the mechanical cooling is operated by stage 2 cooling on the space thermostat.

When the enthalpy of the outdoor air is above the setpoint, the outdoor air damper closes to its minimum position. A call for cooling from the space thermostat brings on mechanical cooling.

During the unoccupied period, the damper actuator returns the outdoor air damper to the fully closed position.

CHECKOUT AND TROUBLESHOOTING

To perform checkout and troubleshooting, follow the procedures in Table 1.

Table 1. H705A Checkout and Troubleshooting.

Checkout Procedure	Response
A. With factory-installed 620 ohm resistor connected across terminals SR and + and outdoor air sensor disconnected (terminals So and + open), apply power (24 Vac) to terminals TR and TR1.	Light emitting diode (LED) should be off. Control terminals 2,3 open; terminals 1,2 closed.
B. Disconnect factory-installed 620 ohm resistor from terminals SR and +.	LED should turn on. Control terminals 2,3 closed; terminals 1, 2 open.
C. Re-connect factory-installed 620 ohm resistor across terminals SR and +. Connect 1.2K ohm checkout resistor (Accessory part number 4074EJM) across terminals SO and +. Turn enthalpy setpoint potentiometer to A.	LED should turn on, indicating low enthalpy.
D. With resistors installed as in procedure C above; turn enthalpy setpoint potentiometer to D.	LED should turn off, indicating high enthalpy.
E. Connect a dc milliammeter between terminal SO of H705A and terminal S of the outdoor air sensor. (See Fig. 8.) If using differential enthalpy, the return air sensor may be checked by connecting a dc milliammeter between terminal SR of the H705A and terminal S of the return air sensor.	Milliammeter should indicate between 3 and 25 mA if sensor is operating properly. If milliammeter indicates zero, the sensor may be wired backward.
Checkout Using Environmentally Safe Coolant Spray	Response
A. Verify that the enthalpy sensor is connected to SO and + and factory-installed 620 ohm resistor is connected across terminals SR and +. Turn enthalpy setpoint to A. With power connected, spray environmentally safe coolant, such as Envi-Ro-Tech 1672-10S, into upper left vent of sensor to simulate low enthalpy conditions. See Fig. 9.	LED turns on in approximately one minute. Control terminals 2, 3 closed; terminals 1,2 open.
B. Disconnect power at TR and TR1.	Control terminals 2,3 open; terminals 1,2 closed.
C. If using differential enthalpy, verify that the outdoor sensor is connected to terminals SO and + and the return air sensor is connected to terminals SR and +. Turn enthalpy setpoint to D (fully clockwise ). With power connected, spray environmentally safe coolant into upper left vent of H705A Enthalpy Sensor connected to SO and + to simulate low outdoor air enthalpy. See Fig. 9.	LED turns on. Control terminals 2,3 closed; terminals 1,2 open.
D. Spray small amount of environmentally safe coolant into upper left vent of prereturn air C7400A Enthalpy Sensor connected to SR and + to simulate low return air enthalpy. See Fig. 9.	LED turns off. Control terminals 2,3 open; terminals 1,2 closed.

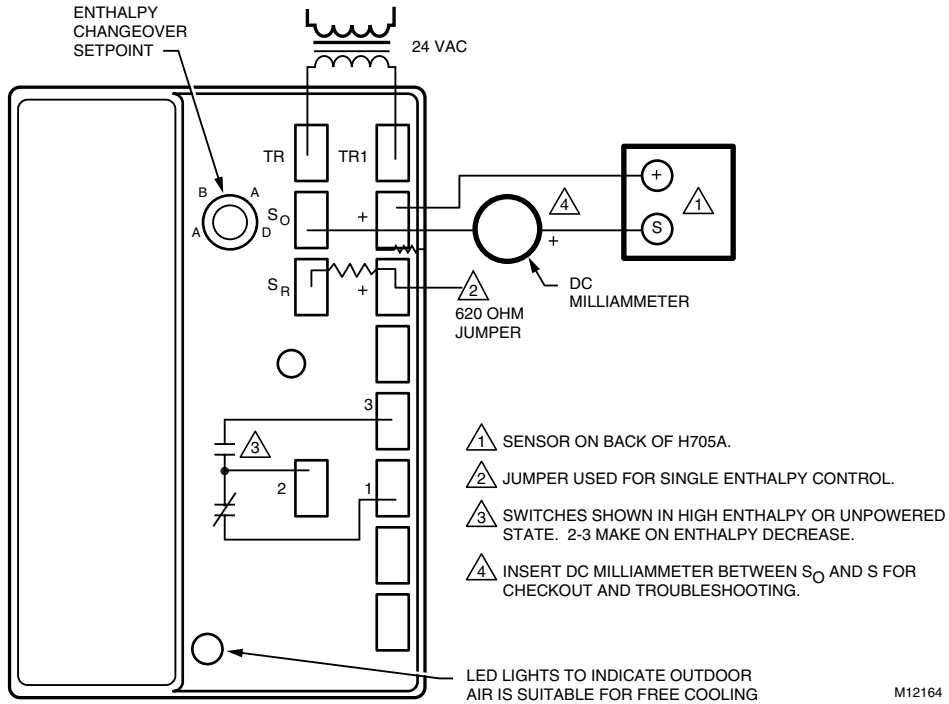

M12164

Fig. 8. Simplified schematic of H705A control circuit and meter location for checkout and troubleshooting.

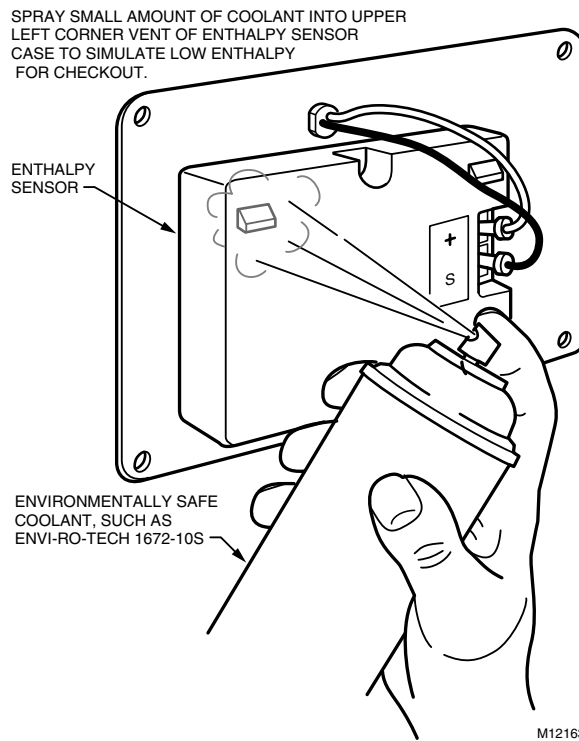

M12163

Fig. 9. Use of environmentally safe coolant spray on sensor to simulate low enthalpy during system checkout.

By using this Honeywell literature, you agree that Honeywell will have no liability for any damages arising out of your use or modification to, the literature. You will defend and indemnify Honeywell, its affiliates and subsidiaries, from and against any liability, cost, or damages, including attorneys' fees, arising out of, or resulting from, any modification to the literature by you.

Home and Building Control

Honeywell Inc.
Honeywell Plaza
P.O. Box 524
Minneapolis MN 55408-0524

Honeywell Latin American Division

Miami Lakes Headquarters
14505 Commerce Way Suite 500
Miami Lakes FL 33016

Home and Building Control

Honeywell Limited-Honeywell Limitée
155 Gordon Baker Road
North York, Ontario
M2H 2C9

Honeywell Europe S.A.

3 Avenue du Bourget
B-1140 Brussels Belgium

Honeywell Asia Pacific Inc.

Room 3213-3225
Sun Hung Kai Centre
No. 30 Harbour Road
Wanchai
Hong Kong

Honeywell

Helping You Control Your World®