



BERMUDA

Gas-Fired Steam Boiler

Designed for reliability, efficiency and performance. For residential and small commercial applications with approved chimney.



BSI Near Boiler Piping Kits are designed to save time and money. The near boiler piping kit will assist in delivering “dry” steam to the heating system, reduce short cycling, eliminate water hammering and protect against system flooding. Kit includes all components required to complete the near boiler piping as recommended in the installation manual.



- Cast iron heat exchanger
- Stainless steel burners
- Built-in draft diverter to fit low spaces
- Automatic vent damper included
Models BSI069 through BSI276
- Attractive, rugged jacket
- Fully assembled or available as knock-down package
- Ten sizes from 69 to 379 MBH
- Designed for installation on combustible floors

Quality
Value &
Service

BSI SERIES - BERMUDA TECHNICAL SPECIFICATIONS

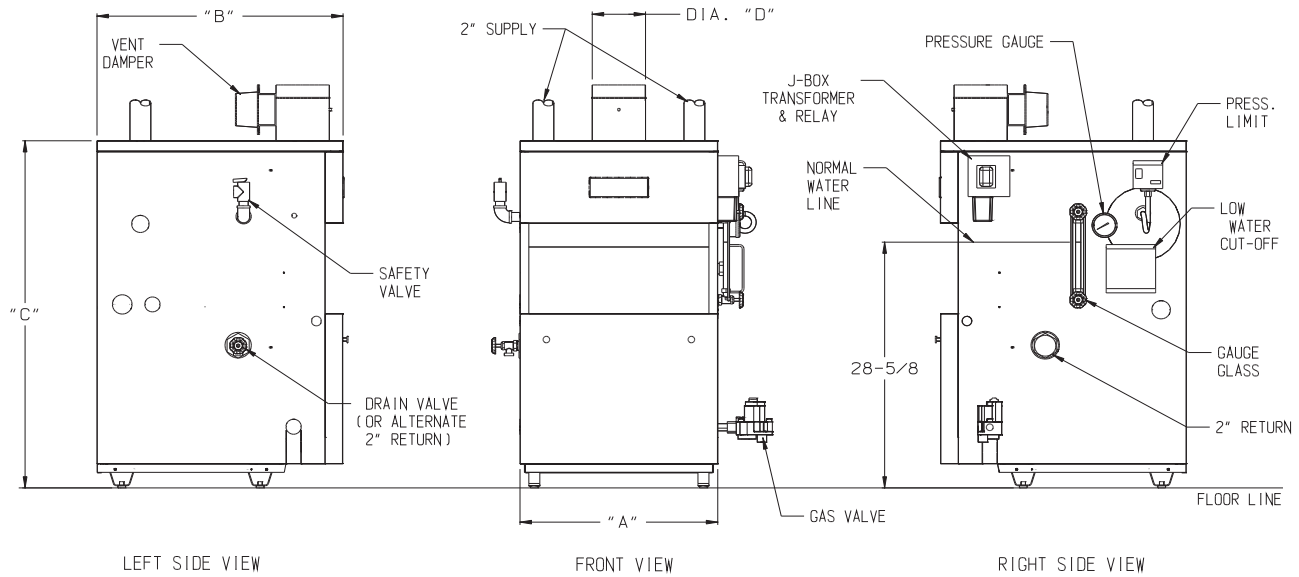

BSI SPACE HEATING RATINGS NATURAL AND LP GAS			AHRI CERTIFIED www.ahrirectory.org			NO. OF SEC.	DIMENSIONS (IN.)				SHIPPING WEIGHT (LBS)
CROWN MODEL NUMBER	INPUT (MBH)	HEATING CAPACITY (MBH)	AHRI NET RATING STEAM (MBH)		AFUE (%)		"A" (in)	"B" (in)	"C" (in)	"D" (in)	
			SQ. FT.	MBH							
BSI069	69	57	179	43	82.0	3	12-3/4	28	40-7/16	4	365
BSI103	103	85	267	64	82.0	4	16	28	40-7/16	5	432
BSI138	138	113	354	85	82.0	5	19-1/4	28	40-7/16	6	504
BSI172	172	142	446	107	82.1	6	22-1/2	28	40-7/16	6	589
BSI207	207	171	533	128	82.1	7	25-3/4	30	40-7/16	7	669
BSI241 [†]	241	199	621	149	82.2	8	29	30	40-7/16	7	745
BSI276 [†]	276	229	717	172	82.2	9	32-1/4	30	40-7/16	8	826
BSI311 [†]	310	240	790	180	77.5**	10	35-1/2	30	45-7/16	8	957
BSI346 [†]	345	267	879	200	77.5**	11	38-3/4	30	45-7/16	9	1044
BSI380 [†]	379	294	966	221	77.5**	12	42	30	45-7/16	9	1125

1. For altitudes above 2,000 ft. - ratings should be reduced at a rate of 4% for each 1,000 ft. above sea level (US only)

[†]Available as semi-packaged boiler.

*Not available for elevations above 2,000 ft. or for use with LP gas

**Thermal efficiency.

All residential cast iron steam boilers include a full one-year warranty. A 12-year limited warranty is provided for the heat exchanger. A 5-year and a 10-year extended warranty covering parts and labor are also available. Visit VelocityBoilerWorks.com or see your warranty for complete details.

ADDITIONAL FEATURES/BENEFITS

- Available with natural or LP gas
- Probe low water cut-off standard; option of float low water cut-off
- Isolation relay simplifies thermostat wiring
- Redundant gas valve
- Roll-out switch; blocked vent switch
- Glass water level gauge set



The Mega-Stor II[®] indirect water heater utilizes the energy created by your boiler to produce abundant hot water for your home. Mega-Stor II water heaters come in a variety of sizes from 30 to 119 gallons to meet a multitude of residential and commercial needs.

Specifications are subject to change without notice.

