

SR Trace Heater Cable for Roof & Gutter Deicing

SR51J & SR52J Heater Cable Installation & Operation



DESCRIPTION

Easy Heat's SR51J and SR52J heater cables prevent ice dam build-up which can damage buildings and gutters. The cables' self-regulating heat output provides additional benefits:

- Lower energy consumption. The cable reduces its power output as the ice and snow disappear.
- High temperature limited. The cable reduces its temperature as it warms, so this minimizes the effect of heat on the temperature sensitive roof materials.

Use only Easy Heat connection and accessory kits to ensure your installation is safe and conforms with electrical code requirements. SR Trace cables are generally suitable for use on asphalt or wood shingles, metal roofing or "membrane" type roofing. Consult roofing supplier for details.

ACCESSORIES

- **ZH-C Roof Clips** are used for all types of installations.
- **DSH Downspout Hangers** support the heater cable descending a downspout drain. One hanger is required for each downspout. Cable must be looped to the bottom of downspout and back up, utilizing a downspout hanger to prevent cable from being pulled tight against the drain/gutter edge.
- **SRP Power Connection Kit** connects power to heater cable and terminates tail end of cable.
- **SRSRG Splice Kit** splices two pieces of cable together. This may be required when a longer circuit is needed or to repair a damaged segment of cable. (Plan splice location to avoid long-term submersion.)

Additional accessories are available.

Principle of Operation

As snow accumulates on a roof in winter, inadequate ceiling insulation and/or roof venting can allow the roof surface above heated areas of the building to get warm enough to melt some of the snow on the roof surface, even on cold winter days.

This water will then flow down the roof and may accumulate and freeze in gutters, possibly even overflowing them and forming long icicles. (Icicles are usually a symptom of this "warm roof" problem. It can be expected that roofs with icicles will eventually form ice dams which may result in water leaking into the building.)

Left unchecked, this ice build-up (icing) can result in significant stress on the gutter, often leading to mechanical failure of the gutter.

It is also probable that the roof area above the overhang will be cold, since it is not above a heated area of the building. This can result in the re-freezing of the melt-water as it approaches the roof edge, forming a layer of ice.

Continued freezing of this water causes the layer of ice to build up in thickness and eventually can become several inches thick. This results in water "ponding" at the warm/cold transition point of the roof, and migrating under the shingles.

Once water gets under the shingles, it can leak through the roof sheathing, at nail holes or other roof penetrations, and down inside the building walls, ceiling, etc. It is also possible for such water to track along ceiling beams and eventually leak into the building interior at light fixtures or through the ceiling finish at a point some distance away from the location of the ice dam.

By applying heating cable from the roof edge to a level just above the overhang, and in the gutter and downspouts, melt-water on the roof will have a clear drainage path.

WARNINGS!

- Installation of SR Heater Cable for roof and gutter deicing must be in accordance with the requirements of all applicable electrical and building codes and regulations. Ground-fault protection must be provided. The braid shield must be effectively grounded by a properly-sized equipment grounding conductor or other approved means.
- Do not twist bus wires together – this will result in a short circuit and damage the cable.
- Moisture must be kept away from the live electrical parts of the cable or electrical faults will develop.
- Damaged heater cables must be repaired or replaced.
- Do not place ladders against the heater cable.
- Minimum Installation Temp: -40°C (-40° F).

Specification/Application Information

Performance and Rating Data

Catalog Number	SR51J	SR52J
Voltage (VAC)	120	208/240/277
Nominal Power Output in Ice (W/ft)	8.0	7.0/8.0/10.0
Maximum Single Cable Length (ft)	190	381

Current Load (Amp/ft)

at 0°F (-20°C) start-up	.132	.066
at -20°F (-30°C) start-up	.147	.074

Minimum Installation Temp: -40° F (-40°C)

Cable Sizing

The total heater cable length for deicing is determined by including all elements of the roof system that need protection. Use the following charts to determine the total length of cable.

Table 1: Determination of Total Cable Requirements

Items	Cable Required
Roof Edge	From Table 2 based on eave overhang
Gutter	1 ft of cable per foot of gutter (if gutter is wider than 6", use 2 traces)
Downspout	2 ft of cable per foot of downspout—cable is looped down and back
Roof Valley	6 ft of cable per valley—loop 3' up valley and back
Dormer Perimeter	1 ft of cable per foot of dormer perimeter

Perform Maximum total Heater Length (ft)/Circuit Breaker Rating 20°F(-7°C)/0°F(-20°C)/-20°F(-30°C) Start-up once and Rating Data

Catalog Number	SR51J	SR52J
15 Amp Breaker	125/115/100	250/225/205
20 Amp Breaker	170/150/135	335/300/270
30 Amp Breaker	250/225/205	500/455/405

The use of ground fault equipment protection for heating cable applications is required by NEC.

Table 2: Cable Length Factors vs. Roof Overhang

Eave Overhang "E"	Loop Height "H"	Length Factor Shingle Roof	Length Factor Metal Roof
12"	18"	1.9	2.5
24"	30"	2.7	3.5
36"	42"	3.6	4.5
48"	54"	4.6	5.5 (Note 3)

Cable length required = Length Factor x Roof Length

1. Standard shingle roof (see diagram pg. 4).
2. Metal roof (see diagram pg. 4).
3. Cable length calculated above does not include cable for gutter or downspout.

For other designs, contact representative.

Cable Control

The Easy Heat SR cable can be controlled in several different ways. The simplest method is to use a standard wall switch, turning the switch on only when snow/ice melting is required. It is recommended that a pilot light also be installed to remind the user when the cable is energized.

It is also possible to install controls which automatically sense when snow/ice melting is required, energizing cables accordingly. Contact Easy Heat for details.

Cable Installation Procedures

1. Before installing heater cable in cold weather, allow cable to warm up to room temperature. Grommets and shrink tube included in connection kits should be warm until used (keep inside jacket pocket).
2. Clear all gutters and downspouts of debris (protect hands with gloves).
3. Remove any sharp edges that could damage the heater cable.
4. Mount weatherproof outlet box (not including the kit) in an unobstructed location permitting the heater cable direct access to the roof with minimal unsupported length.
5. Secure heater cable in outlet box, leaving 12" in junction box for connection to power cables. Form a drip loop where the cable exits the junction box; this will prevent water from tracking along the cable and into the junction box.
6. Secure cable to roofing using ZH-C or equivalent clips in appropriate pattern (shingle or metal; see diagrams page 4) with loop height associated with overhang in TABLE 2. Ensure that waterproof integrity of roofing system is maintained. If in doubt, consult with a professional roofer for appropriate advice.
7. Position heater cable tail end at the top of cable pattern to minimize possibility of long term submersion of tail seal.
8. Terminate heater cable in outlet box per connection kit procedures. Connect bus wires to power supply using standard wiring connection methods according to cable control method selected above. Connect ground braid to equipment grounding conductor.
9. Apply end seal to heater cable tail per end seal procedure below.



DO NOT CONNECT TAIL BUS WIRES TOGETHER; THIS WILL CAUSE DIRECT SHORT CIRCUIT OF CABLE.

10. It is recommended that the heater cable be megger tested between bus wires and ground braid after installation to verify cable is not damaged. Heater cable should have a minimum insulation resistance of 20 megohms when tested with at least a 500VDC megger; a 2500VDC megger is preferred.
11. Post Warning Label at the branch circuit panel. An additional Warning Label must be affixed to either the weatherproof outlet box or next to the on/off device controlling the heater cable (if used).



ALL WARNING LABELS MUST BE CLEARLY VISIBLE.

LIMITED WARRANTY AND LIABILITY

Easy Heat warrants that if there are any defects in material or workmanship in any heating cable or accessory during the first year after the date of purchase. We will provide new products to replace any defective items, or we will refund the purchase price paid for the accessory or cable, not including any labor or other installation costs. As an alternate, we may elect to repair the cable or accessory at our factory with all shipping and other removal costs borne by the purchaser.

We further warrant that any services performed for the Buyer hereunder will be performed in a good and skillful manner, based on our understanding of pertinent technical data as of the date of performance of such services. Easy Heat's sole responsibility and liability in the event of any defect, error, omission, or failure in the services rendered hereunder shall be to provide corrected services of the type provided for herein, designed to correct such defect, error, omissions, or failure, and in no event shall the Easy Heat's liability with respect to such warranty exceed the amount received by it from the Buyer on account of such services.

Our obligation to provide corrected services, new products, refund the purchase price, or perform the repair described above is conditioned upon (a) the installation of the accessory or cable conforming to the specifications set forth in our installation instructions and (b) the accessory or cable not having been damaged by mechanical or electrical activities unrelated to the operation of the accessory or cable.

A refund of your purchase price, provision of replacement products, repair of the accessory or cable or provision of corrected services as described above, shall be your sole and exclusive remedy for a breach of this warranty. THESE ARE THE SOLE AND EXCLUSIVE WARRANTIES GIVEN BY EASY HEAT WITH RESPECT TO THE GOODS AND SERVICES AND ARE IN LIEU OF AND EXCLUDE ALL OTHER WARRANTIES, EXPRESS OR IMPLIED, ARISING BY OPERATION OF LAW OR OTHERWISE, INCLUDING WITHOUT LIMITATION, MERCHANTABILITY AND FITNESS FOR A PARTICULAR PURPOSE WHETHER OR NOT THE PURPOSE OR USE HAS BEEN DISCLOSED TO EASY HEAT IN SPECIFICATIONS, DRAWINGS OR OTHERWISE, AND WHETHER OR NOT EASY HEAT'S PRODUCTS ARE SPECIFICALLY DESIGNED AND/OR MANUFACTURED BY EASY HEAT FOR YOUR USE OR PURPOSE.

This warranty does not extend to any losses or damages due to misuse, accident, abuse, neglect, normal wear and tear, negligence, unauthorized modification or alteration, use beyond rate capacity, or improper installation, maintenance or application. To the extent that you or your agents have supplied specifications, information, representation of operating conditions or other data to Easy Heat in the selection or design of the Goods and the preparation of Easy Heat's quotation, and in the event that actual operating conditions or other conditions differ from those represented by you, any warranties or other provisions contained herein which are affected by such conditions shall be null and void.

If within thirty (30) days after your discovery of any warranty defects within the warranty period, you notify Easy Heat thereof in writing, Easy Heat shall, at its option, repair, correct or replace F.O.B. point of manufacture, or refund the purchase price for, that portion of the Goods found by Easy Heat to be defective. Failure by you to give such written notice within the applicable time period shall be deemed an absolute and unconditional waiver of your claim for such defects. Goods repaired or replaced during the warranty period shall be covered by the foregoing warranty for the remainder of the original warranty period or ninety (90) days from the date of shipment of the repaired or replaced goods, whichever is longer.

This limited warranty does not cover any costs relating to the repair or replacement of any accessory or cable at the installation site. Our accessories and cables are not easily accessible. A failed accessory or cable usually cannot be easily repaired. Replacement of a failed accessory or cable will require that the materials under which it is installed be removed to permit replacement of the accessory or cable. We will not reimburse any costs relating to the repair or replacement of any accessory or cable at the installation site.

IN NO EVENT, REGARDLESS OF THE FORM OF THE CLAIM OR CAUSE OF ACTION (WHETHER BASED IN CONTRACT, INFRINGEMENT, NEGLIGENCE, STRICT LIABILITY, OTHER TORT OR OTHERWISE), SHALL EASY HEAT'S LIABILITY TO YOU AND/OR YOUR CUSTOMERS EXCEED THE PRICE PAID BY YOU FOR THE SPECIFIC GOODS PROVIDED BY EASY HEAT GIVING RISE TO THE CLAIM OR CAUSE OF ACTION. YOU AGREE THAT WE SHALL NOT BE LIABLE TO YOU OR YOUR CUSTOMERS FOR ANY INCIDENTAL, SPECIAL OR CONSEQUENTIAL OR PUNITIVE DAMAGES. No agent, employee or representative of ours has authority to bind us to any affirmation, representation or warranty concerning the goods sold unless such affirmation, representation or warranty is specifically incorporated by written agreement.

To obtain new products, arrange repair of existing product, or a refund under this warranty, please contact Easy Heat with a description of the defect and proof of purchase at the address noted herein.

TYPICAL METAL ROOF

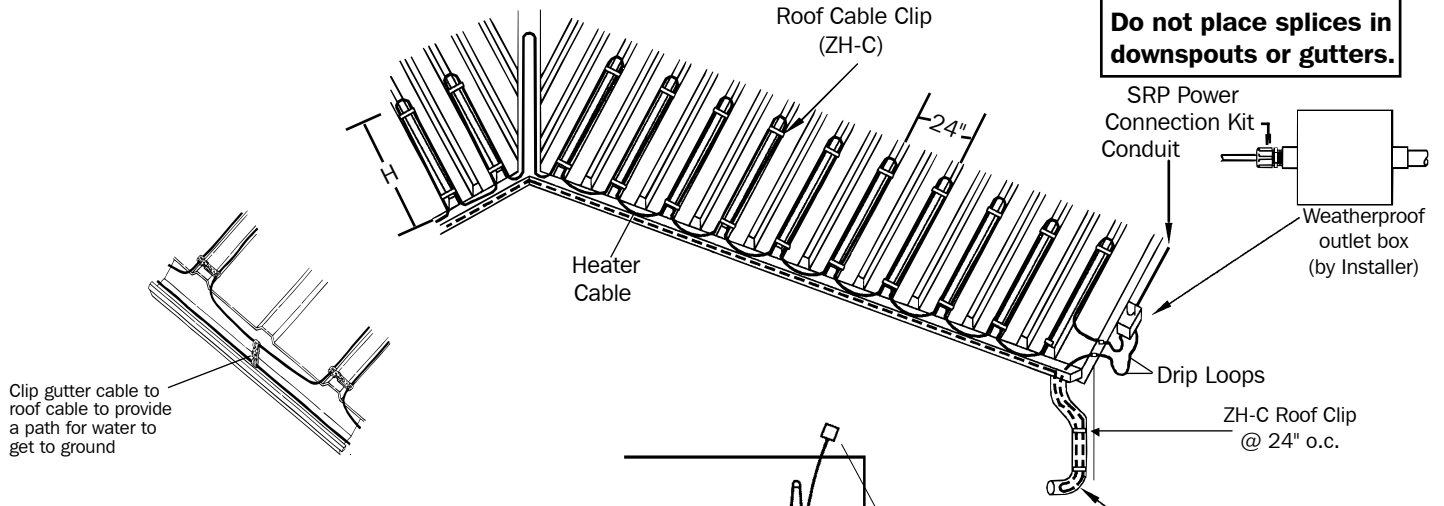

WARNING!
Do not place splices in downspouts or gutters.

TYPICAL SHINGLE ROOF

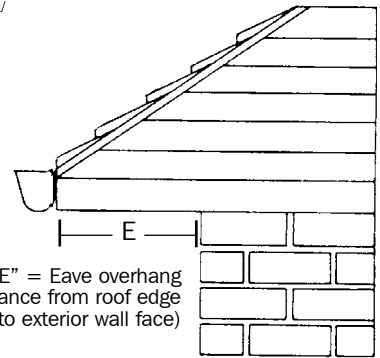
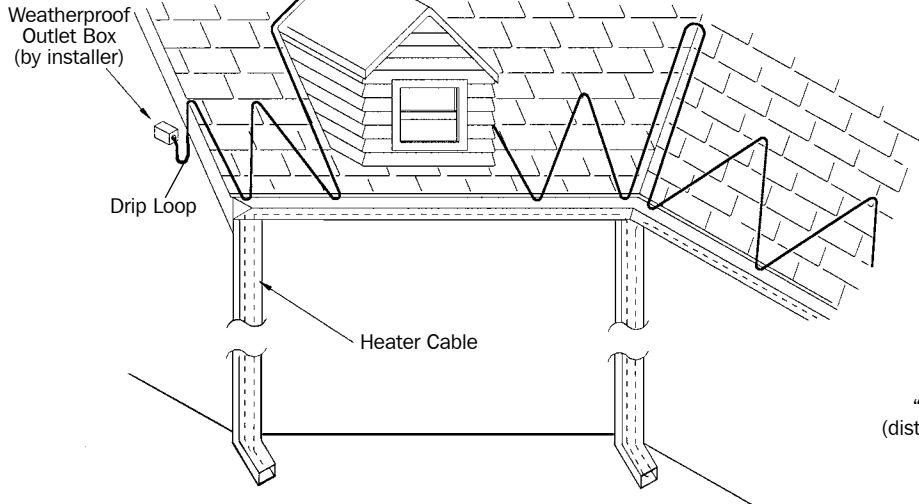
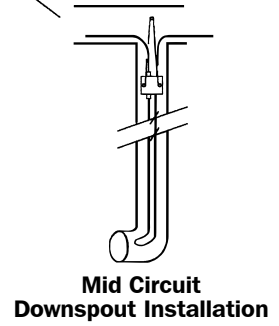
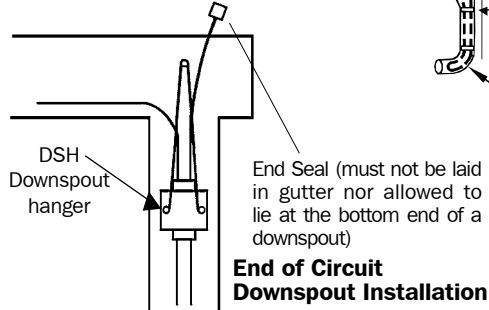
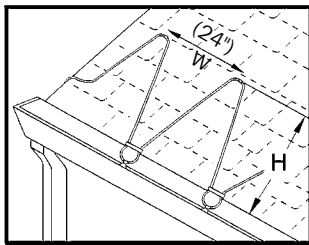

TYPICAL MEMBRANE ROOF

Ice dams may occur on flat roofs typically at the edge of the flashing and at drains. Flat roofs are normally pitched toward drains and these paths can become obstructed by snow and ice. To maintain a path for melt water to run off, install the heating cable as shown below using appropriate attachment methods. Additional heating cable may be required for downspouts.

Note: Heating cable attachment methods are not shown in the diagram below. For attachment we recommend using our ZH-C roof clip. Properly securing this clip to different roofing materials may require differing methods; consult a roofing professional for more information. If the situation warrants it may also be possible to use strips of the roofing membrane to secure the heating cable by adhering the cable under the strip to the main roofing membrane (see figure below).

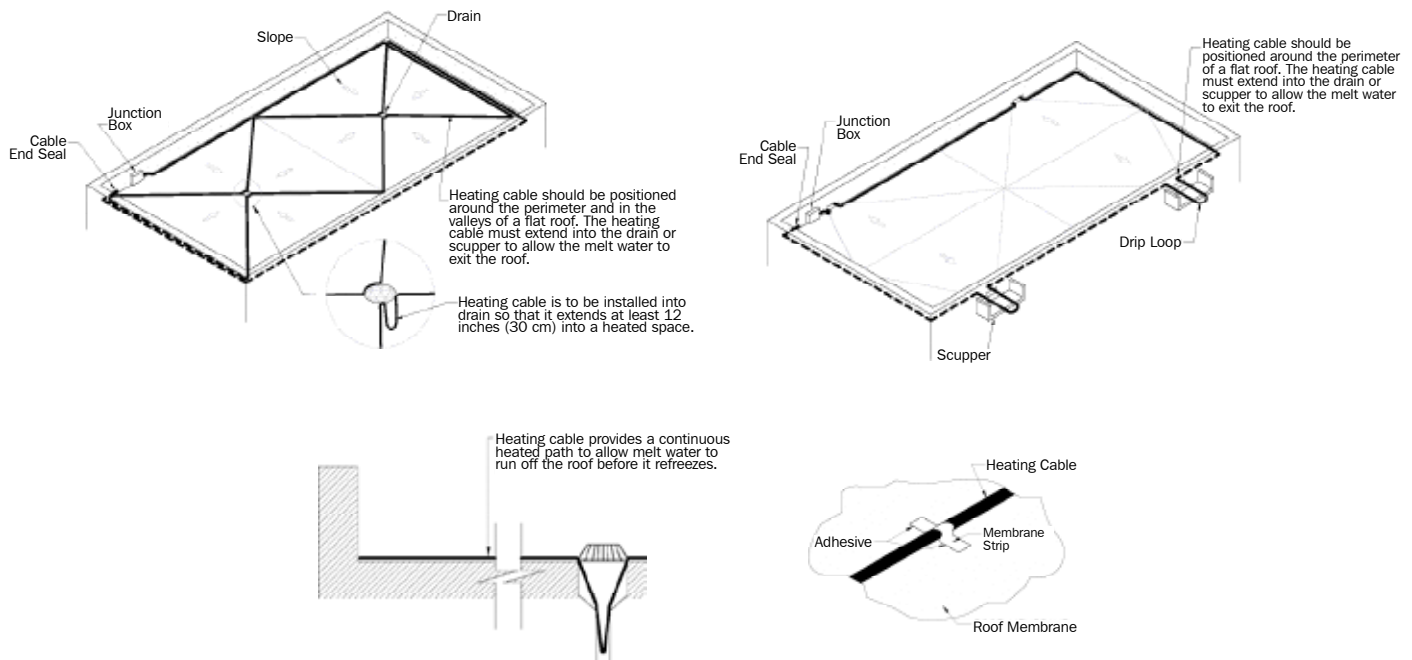

Heating cable layout on flat roof:

- Install heating cable around the perimeter.
- Install heating cable running from the perimeter to the drain.
- Heating cable is to be installed into drain so that it extends at least 12 inches (30cm) into a heated space.

Cable Operation

Energize cables when icing conditions are present on the roof or in gutters; de-energize when icing conditions are no longer present. Ensure power is removed from the cable in summer.

Maintenance

Check cable annually for any damage, such as nicks or cuts possibly caused by animals or other activity on the roof. Check any ground fault protection devices for proper operation. Remove all debris (leaves, twigs, pine needles, etc.) from roof, gutters and downspouts prior to energizing the roof cable. Do not attempt to energize the roof cable if any of these problems are discovered as proper operation may be impaired.