

# AprilAire<sup>®</sup>

## Thermostat



### SAFETY & INSTALLATION INSTRUCTIONS

## Model 8840

Touch Screen Wi-Fi Automation  
Thermostat with Integrated  
Indoor Air Quality Solutions

### TABLE OF CONTENTS

<b>INSTALLATION</b> .....	2	<b>POWER &amp; RESET OPTIONS</b> .....	11
Thermostat Location		<b>SETUP &amp; TESTING</b> .....	11
Recommendations.....	2	Installer Setup Wizard .....	11
Thermostat Mounting .....	2	HVAC Installer System Settings Tables .....	11
Equipment Control Module Location		General System Settings.....	11
Recommendations.....	2	Thermostat System Settings .....	12-14
Equipment Control Module Mounting .....	3	Indoor Air Quality System	
Thermostat Wiring.....	3	Settings Tables.....	14
Remote Temperature Sensor		Humidifier System Settings.....	14-15
(Optional) .....	4	Dehumidifier System Settings.....	16
Support Module Wiring (Optional).....	4	Air Cleaning System Settings.....	16
Equipment Control Module Wiring.....	5	Fresh Air System Settings .....	17-18
Outdoor Temperature Sensor		Installer System Test.....	18
(Included).....	6	WiFi Setup .....	19
Optional Wireless Outdoor		<b>QUICK REFERENCE TO CONTROLS</b>	
Temperature and Humidity Sensor .....	6	<b>&amp; DISPLAY</b> .....	20
Return Air Temperature Sensor		<b>THERMOSTAT FEATURES</b> .....	22
(Optional) .....	7	<b>TROUBLESHOOTING</b> .....	23
Leaving Air Temperature Sensor		<b>SPECIFICATIONS</b> .....	24
(Optional) .....	7		
<b>HVAC WIRING DIAGRAMS</b> .....	8		
Conventional Heat/Cool			
Single Transformer.....	8		
Conventional Heat/Cool			
Two Transformer.....	8		
Heat Pump Single Transformer .....	9		
Heat Pump Two Transformer.....	9		
<b>INDOOR AIR QUALITY WIRING DIAGRAMS</b> .....	10		
Indoor Air Quality Wiring with			
Separate Transformers.....	10		
Indoor Air Quality Wiring with			
a Single Transformer .....	10		

Product Info &  
Digital Manual

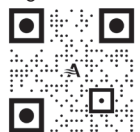

# INSTALLATION

## THERMOSTAT LOCATION RECOMMENDATIONS

### Thermostat should be mounted:

- On an interior wall, in a frequently occupied space.
- Approximately 5 feet above floor.
- At least 18" from outside wall.
- Thermostat can be mounted to a vertical junction box.

### Do not mount thermostat:

- Behind doors, in corners or other dead air spaces.
- In direct sunlight, near lighting fixtures, or other appliances that give off heat.
- On an outside or unconditioned area wall.
- In the flow of a supply register, in stairwells, or near outside doors.
- On a wall with concealed pipes or ductwork.

## THERMOSTAT MOUNTING

1. Remove the rear mounting plate from the thermostat.
2. Pull wires through the opening on the rear mounting plate.
3. Position and level the mounting plate of the thermostat on wall and mark the hole locations with a pencil.
4. Drill 1/4" holes and insert supplied anchors (drywall only).
5. Place mounting plate over anchors, insert and tighten screws.
6. Seal wire entry holes to prevent drafts affecting temperature readings.

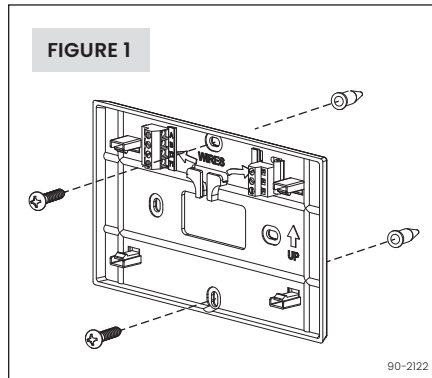

## EQUIPMENT CONTROL MODULE LOCATION RECOMMENDATIONS

**NOTE:** Installer must touch a grounded metal object before handling the equipment control module to avoid potential damage due to electrical discharge.

### Equipment control module should be mounted:

- In a location where the temperature will not exceed 158°F (70°C) or drop below 32°F (0°C).

### Do not mount equipment control module:

- On foundation walls or on the HVAC equipment or ductwork. These locations can cause moisture to condense on the equipment control module.

## EQUIPMENT CONTROL MODULE MOUNTING

The equipment control module has the following features to simplify mounting and wiring and provide for a clean and neat installation.

- Six (6) mounting holes. One on each corner and two centered top and bottom. Any combination of these holes may be utilized. Mount the equipment control module using 2 to 4 #8 screws appropriate for the mounting surface substrate. (See **FIGURE 3**.)
- Wires can be routed through the top, bottom, sides or back.
- Nylon wire ties can be used to secure wires in 10 places.

### Installation steps:

1. Select mounting location.
2. Pull from bottom to remove front cover. (See **FIGURE 2**.)
3. Mount base using 2 to 4 #8 screws (field supplied).

## THERMOSTAT WIRING

### Wire specifications:

- 18-24 gauge thermostat wire

### Installation notes:

- Ensure power at the HVAC equipment is off.
- Loosen screw terminals, insert stripped wire and re-tighten.
- Push the excess wire back into the opening and plug the wall opening to prevent drafts.

<b>1</b>	Connection to terminal 1 at equipment control module
<b>2</b>	Connection to terminal 2 at equipment control module
<b>3</b>	Connection to terminal 3 at equipment control module
<b>A &amp; B</b>	Model 8081 or Model 8082 support module communication (optional)
<b>T1 &amp; T2</b>	Remote temperature sensor (optional)

**FIGURE 2**



**FIGURE 3**

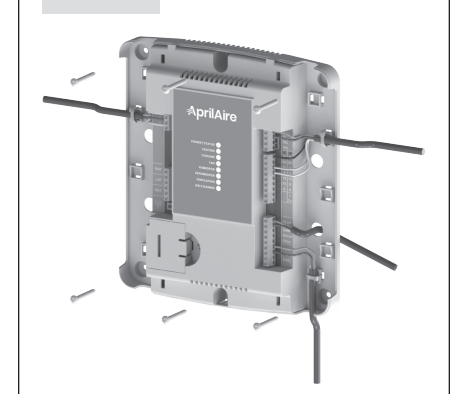

**FIGURE 4 – THERMOSTAT WIRING**

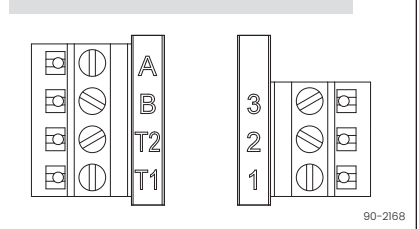

## REMOTE TEMPERATURE SENSOR (OPTIONAL)

A remote temperature sensor can be used for control if the thermostat is to be mounted in a concealed location or a remote sensor can be averaged with the thermostat sensor to control a large space. An 8051 flush mount or 8053 surface mount remote temperature sensor can be attached to the T1 and T2 terminals and mounted in a recommended area. The remote sensor must be enabled in the installer setup menu, and once enabled will override or be averaged with the thermostat's internal temperature sensor, based on the setting.

### Remote temperature sensor should be mounted:

- On an interior wall, in a frequently occupied space.
- Approximately 5 feet above floor.
- At least 18" from outside wall.
- Using less than 300 feet of wire.

### Do not mount remote sensor:

- Behind doors, in corners or other dead air spaces.
- In direct sunlight, near lighting fixtures, or other appliances that give off heat.
- On an outside or unconditioned area wall.
- In the flow of a supply register, in stairwells, or near outside doors.
- On a wall with concealed pipes or ductwork.
- Near 120 VAC lines.

## SUPPORT MODULE WIRING (OPTIONAL)

Up to 4 support modules can be wired for remote sensing of temperature and/or humidity. Each sensor can be configured for control or monitoring.

**NOTE:** Support modules should be wired with CAT-5 wire. The total length of wire for all support modules should not exceed 1000 feet.

**FIGURE 5 – REMOTE TEMPERATURE SENSOR**

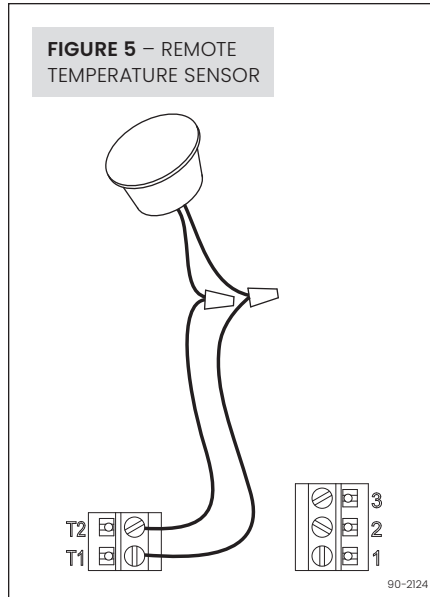

**FIGURE 6 – MODEL 8081 OR 8082 SUPPORT MODULE**

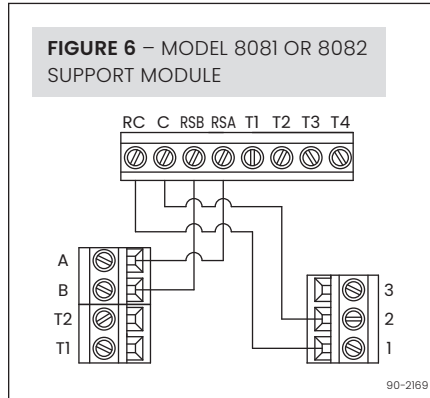

**FIGURE 7 – MODEL 8083 SUPPORT MODULE**

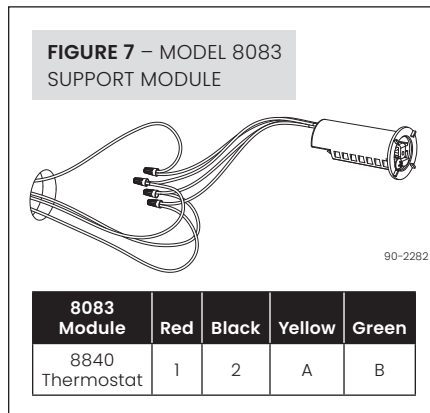

## EQUIPMENT CONTROL MODULE WIRING

### Wire specifications:

- 18-24 gauge thermostat wire

### Installation notes:

- Ensure power at the HVAC equipment is off.
- Loosen screw terminals, insert stripped wire and re-tighten.
- Use zip tie to route wiring through the wiring channels.

1	Connection to terminal 1 at thermostat
2	Connection to terminal 2 at thermostat
3	Connection to terminal 3 at thermostat
RAT	Return air temperature sensor (optional)
LAT	Leaving air temperature sensor (optional)
ODT	Outdoor temperature sensor (included)

C	24VAC common
R	24VAC
RC	24VAC cooling
RH	24VAC heating
W	First stage heat (conventional)/auxiliary (heat pump)
W2	Second stage heat (conventional)/ auxiliary (heat pump)
W3 / B	Third stage heat (conventional)/reversing valve (heat pump)
Y	First stage cooling (conventional)/first stage compressor (heat pump)
Y2	Second stage cooling (conventional)/second stage compressor (heat pump)
Y3 / O	Third stage cooling (conventional)/reversing valve (heat pump)
G	Fan
L	System fault indicator (heat pump only) (optional)
CEQ	24VAC common from heat pump for system fault indicator (optional)
HUM	Humidifier
DHnc & DHcom	Normally closed dehumidifier control
DHno & DHcom	Normally open dehumidifier control
VENT	Ventilation
EAC	Electronic Air Cleaner

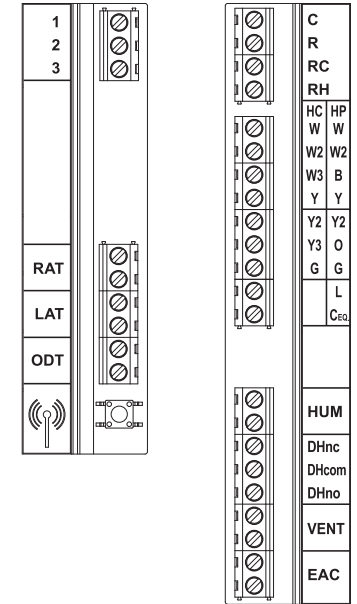

## OUTDOOR TEMPERATURE SENSOR (INCLUDED)

Outdoor temperature can be measured by installing an 8052 sensor to the ODT terminals and enabling the outdoor sensor in the installer setup menu. When an outdoor sensor is installed, the features below will be enabled.

### In heat pump mode the outdoor temperature sensor can be used to efficiently utilize an air source heat pump:

- When the outdoor temperature is less than the Low Balance Point, the heat pump will be locked out and only auxiliary heating will be used to provide heating.
- When the outdoor temperature is higher than the High Balance Point, the auxiliary heating will be locked out and only the heat pump will be used to provide heating.

### Indoor Air Quality functions can use the outdoor temperature sensor to:

- Control humidification setpoint based on outdoor temperature to prevent condensation
- Lock out humidification for temperatures over 60°F or below -30°F.
- Lock out ventilation based on high and/or low outdoor temperatures.
- Display outdoor temperature on thermostat.

### Outdoor temperature sensor should be mounted:

- On side of building out of direct sunlight (north side recommended).
- Above snow line.
- At least 3 feet away from exhaust vents and condensing lines.
- Using less than 300 feet of wire.
- Do not route wires along 120 VAC lines.

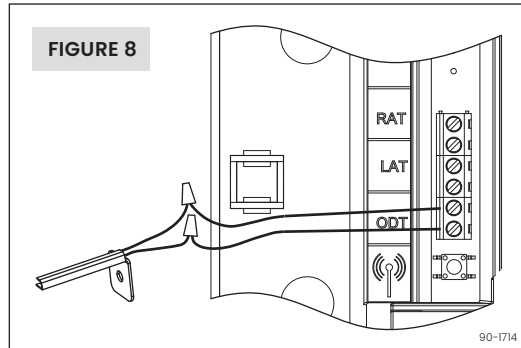

## OPTIONAL WIRELESS OUTDOOR TEMPERATURE AND HUMIDITY SENSOR

For installations where it is difficult to wire the included 8052 outdoor temperature sensor, a Model 8056 wireless outdoor sensor can be used. The Model 8056 module has two radio units, one that is placed on the equipment control module as shown below, and a second radio that is placed outside. See the Model 8056 Installation Instructions for detailed directions regarding installation.

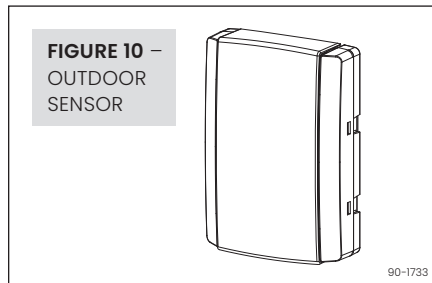
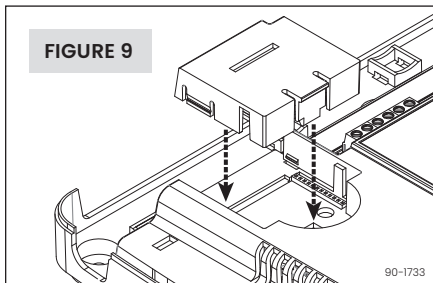

## RETURN AIR TEMPERATURE SENSOR (OPTIONAL)

Return air temperature can be measured by attaching an 8052 sensor to the RAT terminals. The return sensor must be enabled in the installer setup menu. The return air temperature sensor provides protection in the event that the equipment control module loses connection with the thermostat. In the event that the thermostat connection is lost, the equipment control module will use the return air temperature sensor to maintain a temperature greater than 40°F and less than 100°F.

1. Locate the AprilAire Model 8052 sensor in the return trunk.
2. Mount the sensor according to the installation instructions provided with the sensor.
3. Wire the sensor to the equipment control module RAT terminals.

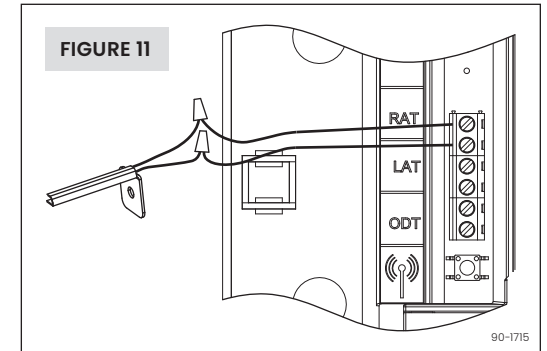

## LEAVING AIR TEMPERATURE SENSOR (OPTIONAL)

Leaving air temperature can be measured by attaching an 8052 sensor to the LAT terminals. The leaving air temperature sensor measurement is displayed during the installer test for diagnostic purposes.

**IMPORTANT:** Do not mount the sensor in direct line-of-sight of the heat exchanger, cooling coils, or UV lights as this may cause the sensor to report false temperature readings.

1. Locate the AprilAire Model 8052 sensor in the supply trunk, after the heat exchanger and cooling coils. (See shaded areas in **FIGURE 12** below.)
2. Mount the sensor according to the installation instructions provided with the sensor.
3. Wire the sensor to the equipment control module LAT terminals.

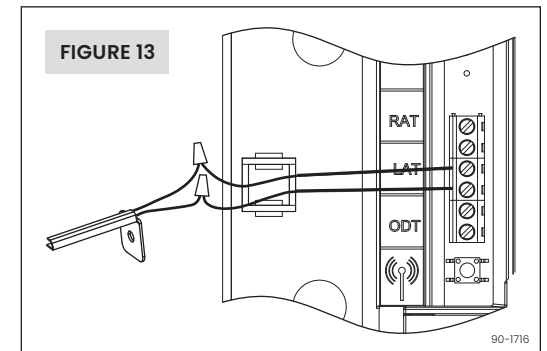
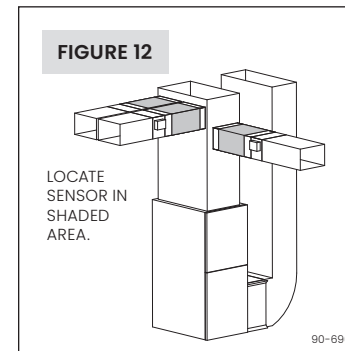

# HVAC WIRING DIAGRAMS

**FIGURE 14 – CONVENTIONAL HEAT/COOL SINGLE TRANSFORMER (USE JUMPER)**

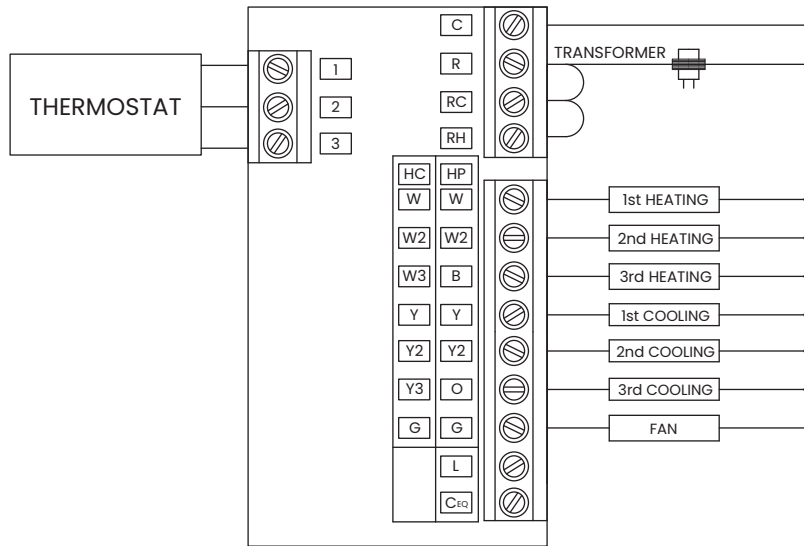

90-1717

**FIGURE 15 – CONVENTIONAL HEAT/COOL TWO TRANSFORMER (REMOVE JUMPER)**

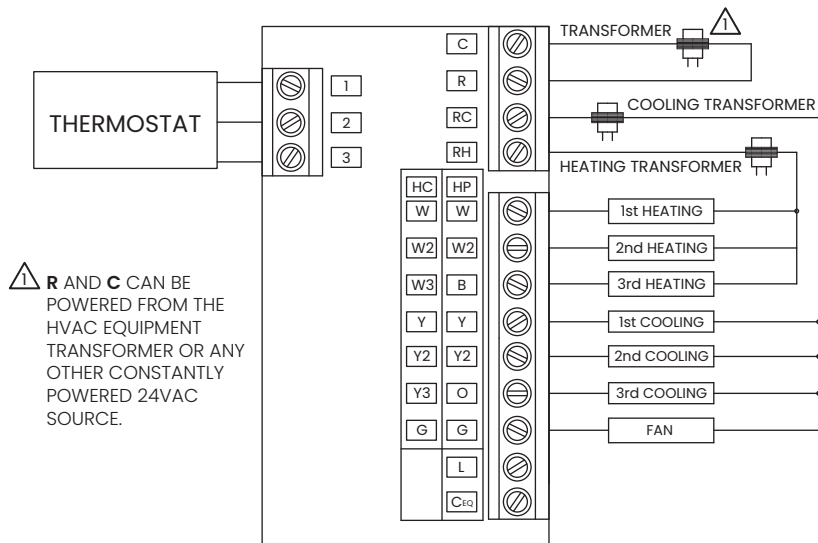

⚠ R AND C CAN BE POWERED FROM THE HVAC EQUIPMENT TRANSFORMER OR ANY OTHER CONSTANTLY POWERED 24VAC SOURCE.

90-1718

**FIGURE 16 – HEAT PUMP SINGLE TRANSFORMER (USE JUMPER WIRE)**

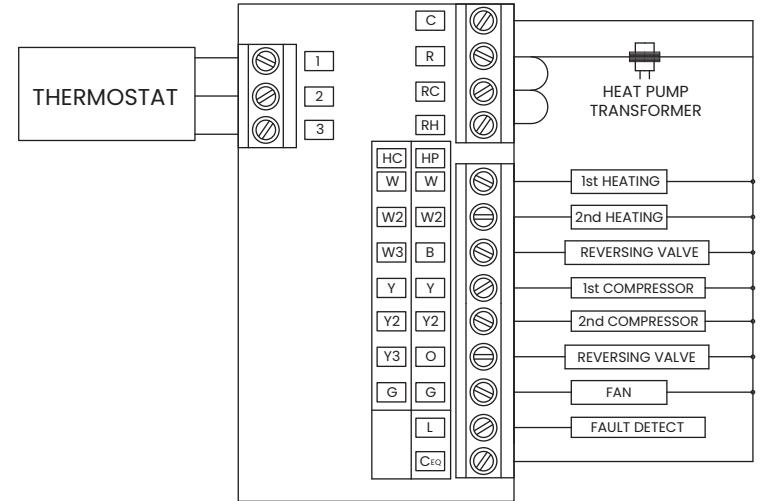

90-1719

**FIGURE 17 – HEAT PUMP TWO TRANSFORMER (REMOVE JUMPER WIRE)**

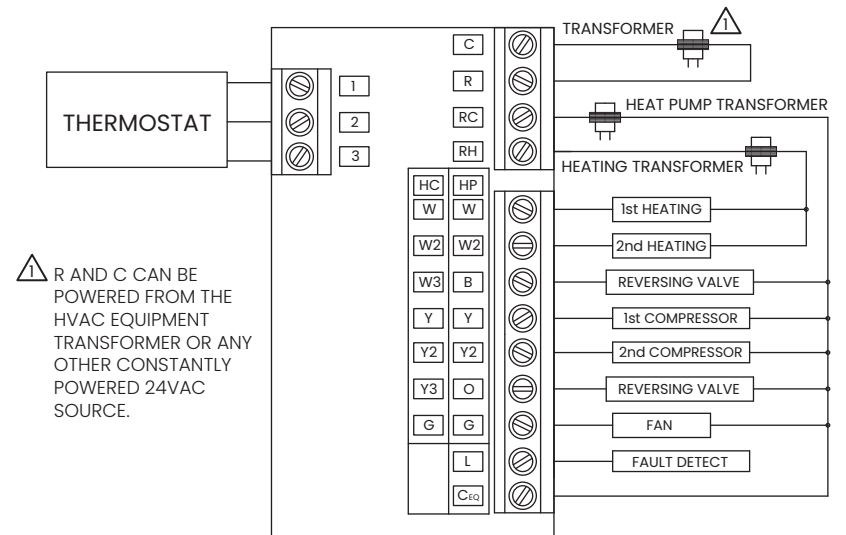

⚠ R AND C CAN BE POWERED FROM THE HVAC EQUIPMENT TRANSFORMER OR ANY OTHER CONSTANTLY POWERED 24VAC SOURCE.

90-1720

## INDOOR AIR QUALITY WIRING DIAGRAMS

**FIGURE 18** – INDOOR AIR QUALITY WIRING WITH SEPARATE TRANSFORMERS

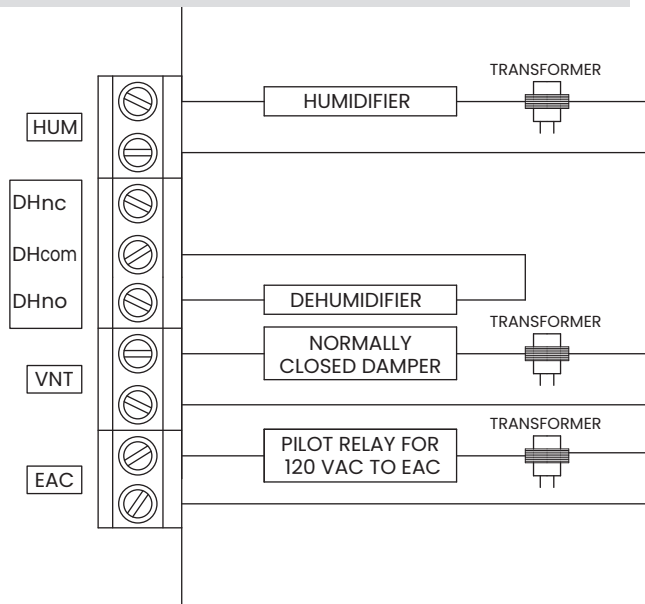

90-1721

**FIGURE 19** – INDOOR AIR QUALITY WIRING WITH A SINGLE TRANSFORMER

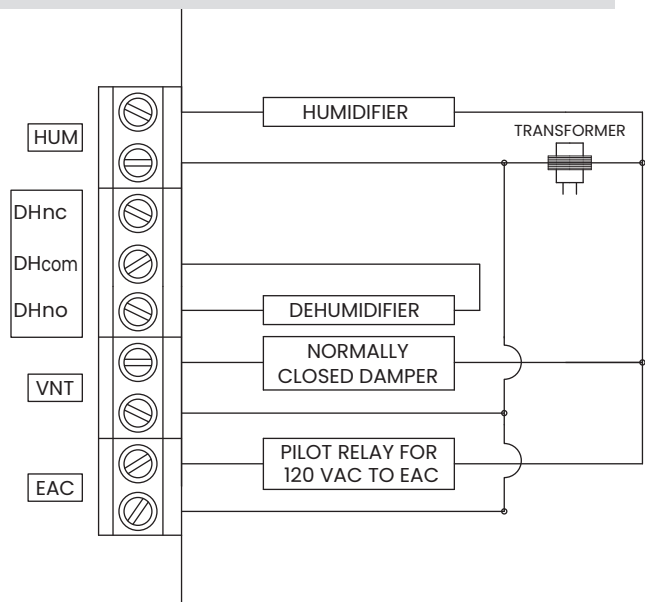

90-1722

## POWER & RESET OPTIONS

The equipment control module is powered from 24VAC. The thermostat is powered from the equipment control module. In the case of power loss the thermostat will maintain the clock for 24 hours. The thermostat has a memory backup that saves the thermostat settings in case of power interruption.

The factory reset is located in the Installer Tools option of the Installer Menu. See Installer System Settings section for details.

## SETUP & TESTING

### INSTALLER SETUP WIZARD

The first time the thermostat is powered up (or after a factory reset) it will enter the Installer Setup Wizard. All installer settings can be set in this process. The installer settings are also accessible in the MENU by pressing the **Contractor Info** button for 10 seconds.

**Import USB settings** will be the first screen that you see (the button will be grayed out until a USB drive is inserted).

- If you have a USB drive with installer setup files on it, insert it into the USB connector (on the lower left corner) to import a file.
- Or press **Skip** to proceed with the Installer Setup Wizard.

**NOTE:** Installer setup files can be created from the Export Setup option found under Installer Menu > Installer Tools > Export Setup.

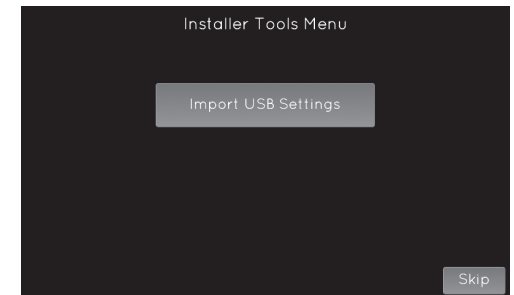

### HVAC INSTALLER SYSTEM SETTINGS TABLES

The following tables contain the system settings and their details. Default settings are shown in **bold**. Some settings are only available dependent upon the value of other settings.

**TABLE 1** – GENERAL SYSTEM SETTINGS

System setting	Description	Factory default setting (bold) and setting range
Connection Type	Selects if the thermostat connects with an automation system or an AprilAire account.	<b>Automation System</b> AprilAire Cloud
Installer Temperature Scale	This selection only effects the installer setup menus.	<b>Fahrenheit</b> Celsius
Contractor Information Input	Enter contractor's contact information.	Company, Phone, Email, Web

TABLE 2 – THERMOSTAT SYSTEM SETTINGS		
System setting	Description	Factory default setting (bold) and setting range
Equipment Type	<b>NOTE:</b> Equipment Type related settings will return to defaults if this is changed.	<b>Heat/Cool</b> Heat Pump
Control Setup	Used to lockout heating or cooling outputs. (Heat/Cool mode only.)	<b>Heat &amp; Cool</b> Heat Only Cool Only
Heat Pump Auxiliary Type	Selects auxiliary type. (Heat Pump mode only.)	<b>Gas/Oil Heat</b> Electric Heat
Fan Control In Heating	Selects thermostat or equipment to control the fan in heating. (Heat/Cool mode only.)	<b>Gas/Oil Heat</b> Electric Heat
Number of Compressor Stages	Select number of compressor stages. (Heat Pump mode only.)	<b>One</b> Two
Number of Auxiliary Heat Stages	Select number of auxiliary heat stages. (Heat Pump mode only.)	<b>One</b> Two
Number of Stages of Heat	Select number of heat stages. (Heat/Cool mode only.)	<b>One</b> Two Three
Number of Stages of Cool	Select number of cool stages. (Heat/Cool mode only.)	<b>One</b> Two Three
Remote Temperature Sensor Installed?	Select if the remote sensor is attached, and uses backup, or is averaged with built-in.	<b>No</b> Yes Yes (fallback built-in) Yes (average w/built-in)
Return Air Temperature Sensor Installed?	Select if return air temperature sensor is attached or not.	<b>No</b> Yes
Outdoor Temperature Sensor Installed?	Select if outdoor sensor is attached or not.	<b>No</b> Yes Automation
Display Support Modules	Select if support module values are displayed on Monitored Climate screen under Status.	<b>No</b> Yes
Number of Controlling Support Modules Temp	Select number of sensors configured to be controlling temperature.	<b>0-8</b>
Number of Controlling Support Modules RH	Select number of sensors configured to be controlling RH.	<b>0-4</b>
Schedule	Enables or disables programmable schedule.	<b>Enabled</b> Disabled
Progressive Recovery	Enables or disables progressive recovery.	<b>Enabled</b> Disabled
Display Away Button?	Away allows the user to set the thermostat to a predefined setpoint using a single button press. The predefined setpoints can be selected in the User Settings.	<b>No</b> Yes

TABLE 2 – THERMOSTAT SYSTEM SETTINGS		
System setting	Description	Factory default setting (bold) and setting range
Display Heat Blast Button?	Select if the Heat Blast button is displayed.	<b>No</b> Yes
Blast Offset	Amount of heating when Heat Blast is initiated.	<b>3°F (1.5°C)</b> 4°F (2°C) 5°F (2.5°C)
Extended Fan – Heat	Extends fan operation after heat call ends.	<b>Disabled</b> Enabled
Extended Fan – Cool	Extends fan operation after cool call ends.	<b>Disabled</b> Enabled
Auto Changeover	Enable or disable Auto Changeover mode.	<b>Disabled</b> Enabled
DeadBand	Auto Changeover mode deadband.	<b>3°F (1.5°C)</b> 2 to 9°F (1 to 4.5°C)
Auto Changeover Time	Minimum time between heating and cooling calls.	<b>4 Minutes</b> 1 to 5 Minutes
Internal Temperature Sensor Offset	Field adjustment of controlling temperature sensors.	<b>0°F (0°C)</b> -4 to 4°F (-2 to +2°C)
Internal RH% Sensor Offset	Field adjustment of internal RH sensor.	<b>0</b> -5 to 5
Equipment Minimum On Time	Minimum on time for heating and cooling.	<b>2 Minutes</b> 1 to 5 Minutes
Heating Minimum Off Time	Minimum off time for heating.	<b>2 Minutes</b> 1 to 5 Minutes
Compressor Minimum Off Time	Minimum off time for compressor protection.	<b>5 Minutes</b> 1 to 5 Minutes
Outdoor Temperature High Balance Point	Enable or disable high balance point (Available if ODT is installed.)	<b>Enabled</b> Disabled
Select High Temperature Balance Point	If outside temperature is above the high balance point the aux heat operation is not allowed. (Available if high balance point is enabled.)	<b>65°F (14.5°C)</b> 0 to 80°F (-18 to 22°C)
Outdoor Temperature Low Balance Point	Enable or disable low balance point (Available if ODT is installed.)	<b>Enabled</b> Disabled
Select Low Temperature Balance Point	If outside temperature is below the low balance point the compressor operation is not allowed. (Available if low balance point is enabled.)	<b>20°F (-8°C)</b> 0 to 60°F (-18 to 12°C)
Stage Rate	Accumulation of equipment run time in staging determination.	<b>Enabled</b> Disabled
Factor	1 = more rapid staging of equipment (comfort), 5 = slower staging of equipment (economy).	<b>2</b> 1 to 5
First Stage Differential	First stage differential.	<b>1°F (0.5°C)</b> 1 to 9°F (0.5 to 4.5°C)



TABLE 2 – THERMOSTAT SYSTEM SETTINGS		
System setting	Description	Factory default setting (bold) and setting range
Second Stage Differential	Second stage differential.	<b>1°F (0.5°C)</b> 1 to 9°F (0.5 to 4.5°C)
Third Stage Differential	Third stage differential.	<b>1°F (0.5°C)</b> 1 to 9°F (0.5 to 4.5°C)
Fourth Stage Differential	Fourth stage differential.	<b>1°F (0.5°C)</b> 1 to 9°F (0.5 to 4.5°C)
Service HVAC Reminder	The period for displaying the <b>HVAC Service reminder</b> message.	<b>Disabled</b> Enabled
Number of Months for Recurrence	Select number of months for displaying reminder.	<b>12 Months</b> 1 to 12 Months

### INDOOR AIR QUALITY SYSTEM SETTINGS TABLES

The following tables contain the Indoor Air Quality system settings and their details. Default settings are shown in **bold**. Some settings are only present dependent upon the value of other settings.

The use of an outdoor temperature sensor (recommended) enables additional Indoor Air Quality functionality.

Please refer to the Model 8840 Owner's Manual for further information about thermostat features.

**NOTE:** Refer to manuals for humidifier, dehumidifier, air cleaner, and ventilation products for recommended installation and operation.

TABLE 3 – HUMIDIFIER SYSTEM SETTINGS		
System setting	Description	Factory default setting (bold) and setting range
Humidifier Installed?	Selects if a humidifier is installed. <b>Yes/On HVAC</b> is used for applications where the humidifier is installed on the HVAC duct. <b>Yes/Standalone</b> is used for application where the humidifier is independent of the HVAC system. (If set to <b>No</b> , no other humidifier settings will be available.)	<b>No</b> Yes/On HVAC Yes/Standalone
Display Button?	<b>NOTE:</b> Only available if <b>Humidifier Installed</b> is set to <b>No</b> .	<b>Yes</b> No
Outdoor Temperature Sensor Installed?	Select if outdoor sensor is attached or not.	<b>No</b> Yes
Humidifier Mode	Selects auto or manual mode. Auto mode controls humidity based on the humidity setting and outdoor temperature. Manual mode controls humidity based on the %RH setpoint. (Auto mode is only available if <b>Outdoor Sensor</b> is set to <b>Yes</b> or <b>Automation</b> .)	<b>Auto</b> Manual

TABLE 3 – HUMIDIFIER SYSTEM SETTINGS		
System setting	Description	Factory default setting (bold) and setting range
Allowed Humidifier Operation	Selects when humidification is allowed to occur relative to heating and fan operation. Without Fan allows humidification to occur without the HVAC fan. This option should only be used when the humidifier is independent of the HVAC system. <b>NOTE: Without Fan</b> is only available when <b>Humidifier Installed</b> is set to <b>Yes/Standalone</b> .	Heat Only Heat or Fan <b>Forces Fan</b> Without Fan
<b>▲CAUTION:</b> When <b>Humidifier Operation</b> is set to <b>Without Fan</b> the thermostat will turn on humidification without energizing the HVAC fan. Do not select this option when the humidifier is installed on the HVAC duct. Without airflow moisture can accumulate in the duct resulting in significant damage.		
Humidity Deadband	Select the minimum difference between the humidifier and dehumidifier setpoints. (Only available if both a humidifier and dehumidifier are installed.)	<b>10%</b> 10 to 20%
Humidifier Reminder	Selects when the <b>Change Water Panel</b> message is displayed.	<b>Off</b> 300h Valve 600h Valve 1 per season 2 per season
Single or First Reminder Appears	Determines the month the first (or only) <b>Change Water Panel</b> message is displayed.	<b>October</b> November December January February March April May June July August September
Second Reminder Appears	Determines the month the second <b>Change Water Panel</b> message is displayed.	October November December <b>January</b> February March April May June July August September



TABLE 4 – DEHUMIDIFIER SYSTEM SETTINGS		
System setting	Description	Factory default setting (bold) and setting range
Dehumidifier Type Installed?	Selects if a dehumidifier is installed. (If set to <b>None</b> , no other dehumidifier settings will be available.)	<b>None</b> Whole Home Air Conditioner
Display Button?	<b>NOTE:</b> Only available if <b>Dehumidifier Installed</b> is set to <b>None</b> .	<b>Yes</b> No
Disable Dehumidification During Cooling?	Selects if a dehumidifier is disabled during a cooling call.	<b>Yes</b> No
Dehumidifier Forces Fan?	Selects if dehumidification can turn on the fan.	<b>Yes</b> No
Dehumidifier Overcooling Limit	Selects the amount of overcooling that can occur for dehumidification. (Only available if <b>Dehumidifier Type</b> is set to <b>Air Conditioner</b> .)	1°F (0.5°C) 2°F (1°C) <b>3°F (1.5°C)</b>
Dehumidifier Reminder	The period for displaying the <b>Dehumidification Service Reminder</b> message.	<b>Disabled</b> Enabled
Number of Months for Recurrence	Select number of months for displaying reminder.	<b>12 Months</b> 1 to 12 Months
Dehumidify in Vacation Hold?	Selects if dehumidification with the air conditioner is done in vacation mode.	<b>No</b> Yes
Vacation Hold Low Temperature Limit	Sets the lowest temperature the air conditioner will cool to, to meet RH setpoint in Vacation Mode. (Only available if <b>Dehumidifier Type</b> is set to <b>Air Conditioner</b> .)	<b>75°F (24°C)</b> 70 to 85°F (21 to 29.5°C)
Humidity Deadband	Select the minimum difference between the humidifier and dehumidifier setpoints. (Only available if both a humidifier and dehumidifier are installed.)	<b>10%</b> 10 to 20%

TABLE 5 – AIR CLEANING SYSTEM SETTINGS		
System setting	Description	Factory default setting (bold) and setting range
Air Cleaner Installed?	Selects if an air cleaner is installed. (If set to <b>No</b> , no other air cleaner settings will be available.)	<b>No</b> Yes
Display Button?	<b>NOTE:</b> Only available if <b>Air Cleaning Installed</b> is set to <b>No</b> .	<b>Yes</b> No
Air Cleaner Reminder	The period for displaying the <b>Change Air Filter</b> message.	<b>Disabled</b> Enabled
Number of Months for Recurrence	Select number of months for displaying reminder.	<b>12 Months</b> 1 to 12 Months

TABLE 6 – FRESH AIR SYSTEM SETTINGS		
System setting	Description	Factory default setting (bold) and setting range
Fresh Air Vent Installed	Selects if ventilation is installed. (If set to <b>No</b> , no other ventilation settings will be available.)	<b>No</b> Yes
Display Button?	<b>NOTE:</b> only available if <b>Fresh Air Installed</b> is set to <b>No</b> .	<b>Yes</b> No
Fresh Air Setup Type	Selects if ventilation is configured through the Code setup or Comfort. Comfort setup has more lockout options. Code setting ensures missed lockout time is made up.	<b>Comfort</b> Code
Number of Bedrooms	Selects the number of bedrooms to be used for the Calculated Minutes per Hour.	<b>3 Bedrooms</b> 1 to 10 Bedrooms
Home Size	Selects the size of the home to be used for the Calculated Minutes per Hour.	<b>2500 SQ FT</b> 500 to 7500 SQ FT
Measured CFM	Selects the ventilation CFM to be used for the Calculated Minutes per Hour.	<b>110 CFM</b> 30 to 250 CFM
Calculated Minutes per Hour	Displays the Fresh Air Time calculated.	<b>None</b> Range 6 to 60 Minutes
Override	Manual adjustment of Calculated Minutes per Hour.	<b>(Calculated Minutes per Hour)</b> Range 6 to 60 Minutes
Outdoor Temperature Sensor Installed?	Select if outdoor sensor is attached or not.	<b>No</b> Yes
Enable High Vent RH Limit	Selects if ventilation is disabled if the indoor RH exceeds the indoor RH limit. (Only available if <b>Fresh Air Setup</b> is set to <b>Comfort</b> .)	<b>Yes</b> No
High Vent RH Limit	Sets the ventilation indoor RH lockout limit. (Only available if <b>Enable High Vent RH Limit</b> is set to <b>Yes</b> .)	<b>55%</b> 45% to 70%
Enable Low Vent RH Limit	Selects if ventilation is disabled if the indoor RH exceeds the indoor RH limit. (Only available if <b>Fresh Air Setup</b> is set to <b>Comfort</b> .)	<b>No</b> Yes
Low Vent RH Limit	Sets the ventilation indoor RH lockout limit. (Only available if <b>Enable Low Vent RH Limit</b> is set to <b>Yes</b> .)	<b>20%</b> 10% to 30%
Enable High Vent Temperature Limit	Enables high ventilation temperature lockout limit. (Only available if <b>Outdoor Sensor</b> is set to <b>Installed</b> or <b>Automation</b> .)	<b>No</b> Yes
High Vent Temperature Limit	Sets high ventilation temperature lockout limit. (Only available if <b>Enable High Vent Temperature Limit</b> is set to <b>Yes</b> .)	<b>100°F (38°C)</b> 85°F to 105°F (29°C to 41°C)
Enable Low Vent Temperature Limit	Enables low ventilation temperature lockout limit. (Only available if <b>Outdoor Sensor</b> is set to <b>Installed</b> or <b>Automation</b> .)	<b>No</b> Yes

**TABLE 6 – FRESH AIR SYSTEM SETTINGS**

System setting	Description	Factory default setting (bold) and setting range
Low Vent Temperature Limit	Sets low ventilation temperature lockout limit. (Only available if <b>Enable Low Vent Temperature Limit</b> is set to <b>Yes</b> .)	<b>10°F (-12°C)</b> -10°F to 40°F (-24°C to 6°C)
HVAC Fan with Vent	Selects if ventilation forces the fan on. (Yes with high and low limits is only available if <b>Outdoor Sensor</b> is set to <b>Installed</b> or <b>Automation</b> .)	<b>Yes</b> Yes with high and low limits No
Enable High Mixing Temperature	Enables high mixing temperature. (Only available if <b>HVAC Fan with Vent</b> is set to <b>Yes</b> with high and low limits.)	<b>No</b> Yes
High Mixing Temperature	Sets the high mixing temperature. (Only available if <b>Enable High Mixing Temperature</b> is set to <b>Yes</b> .)	<b>80°F or (26°C)</b> 60°F to 105°F (14°C to 41°C)
Enable Low Mixing Temperature	Enables low mixing temperature. (Only available if <b>HVAC Fan with Vent</b> is set to <b>Yes</b> with high and low limits.)	<b>No</b> Yes
Low Mixing Temperature	Sets the Low mixing temperature. (Only available if <b>Enable Low Mixing Temperature</b> is set to <b>Yes</b> .)	<b>40°F (6°C)</b> 0°F to 50°F (-18°C to 12°C)
Fresh Air Service Reminder	The period for displaying the <b>SERVICE FRESH AIR</b> message.	<b>OFF</b> 1 to 12 months or <b>OFF</b> to disable

**INSTALLER SYSTEM TEST**

The Installer Test can be accessed from the Installer Menu. All equipment outputs that are configured in the installer settings can be turned on and off for testing equipment. Minimum on and off times are not enforced while in this mode.

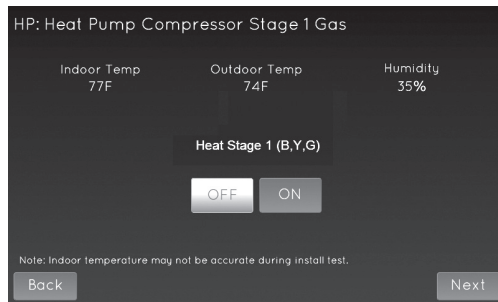

**WI-FI SETUP**

The 8840 can be connected to a Wi-Fi network either at the thermostat or another Wi-Fi device with a web browser.

**STEP 1:** Verify the thermostat is in Wi-Fi Connection Mode.

The thermostat by default will be in Wi-Fi Connection Mode. To confirm that the thermostat is in Wi-Fi Connection Mode, verify that the radio bars on the thermostat are strobing as shown in **FIGURE 20**.

**NOTE:** If the thermostat is not in Wi-Fi Connection Mode, refer to the online owner's manuals found at [aprilaire.com](http://aprilaire.com).

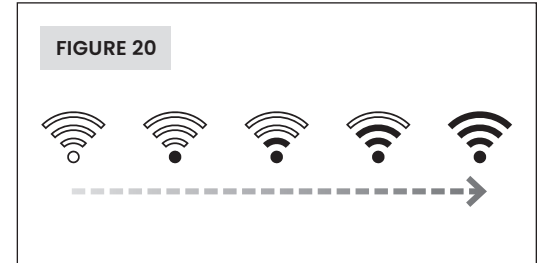

**CONNECT TO A NETWORK USING THE THERMOSTAT**

**STEP 2:** Navigate to the Connect without App screen: **Menu > Wi-Fi Settings > Advanced > Connect without App**.

**STEP 3:** Select a network from the list of scanned networks.

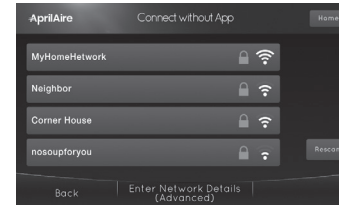

**STEP 4:** Enter a password and press **Done**.



**STEP 5:** Press **Done** on the Credentials screen to connect.

**CONNECT TO A NETWORK USING A BROWSER**

**STEP 2:** Connect to the thermostat using a computer or mobile device.

On your computer or mobile device, scan for available networks. The thermostat should appear as APRILAIRE8840 followed by a unique identifier, corresponding to the last 6 digits of the MAC address. Connect to the thermostat you want to configure.

If you are installing multiple thermostats, the MAC address of each thermostat will be displayed on the Wi-Fi Settings screen, and can be found on the back of the thermostat.

**STEP 3:** Configure the thermostat to connect to the Wi-Fi network.

Open a web browser on your computer or mobile device. In the browser enter: <http://192.168.1.99/index.html>

In the web browser interface select the network you want to connect the thermostat to, and enter the network's security credentials.

**STEP 4:** Verify the thermostat is connected to the Wi-Fi network.

Once all the required information is entered in the web browser interface, the thermostat will connect to the Wi-Fi network you selected. After the thermostat is connected to the Wi-Fi network, the thermostat will display the radio bars based on the Wi-Fi signal strength.

**NOTE:** If you are not using the thermostat with a home automation system, but are instead using an AprilAire account to communicate with the thermostat, refer to **Wi-Fi Thermostat App User Guide** and then **Start Up Guide** on [aprilaire.com](http://aprilaire.com) for instructions on connecting to Wi-Fi and registering to an AprilAire account.

# QUICK REFERENCE TO CONTROLS & DISPLAY

## HOME SCREEN



NOTE: SCREEN BRIGHTENS AFTER FIRST TOUCH.

## MAIN MENU

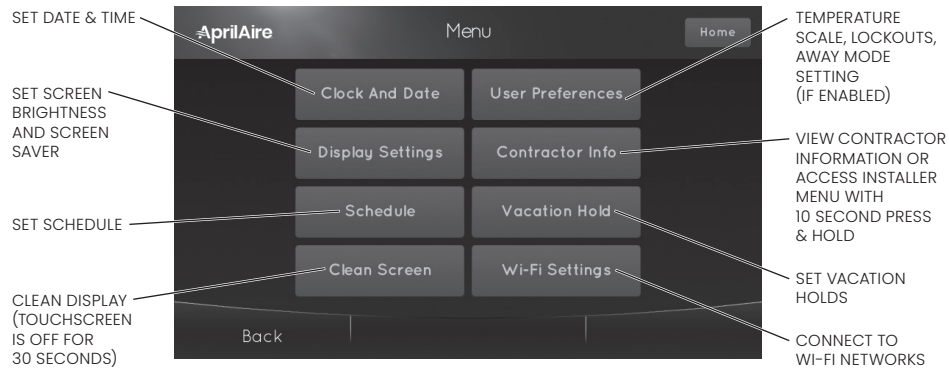

## INSTALLER MENU

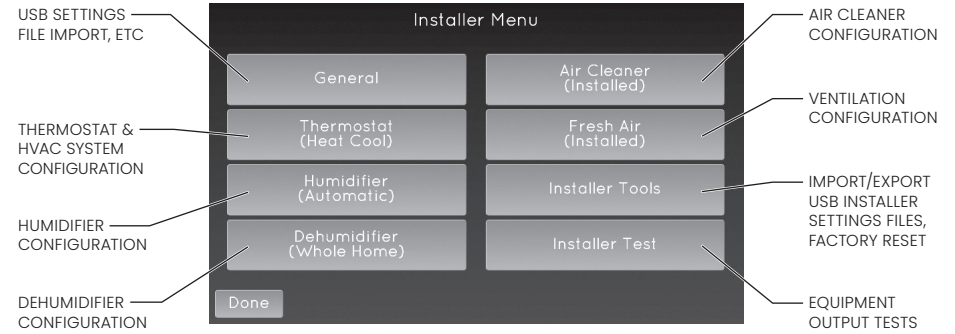

## EQUIPMENT CONTROL MODULE LEDs

<ul style="list-style-type: none"> <li>POWER / STATUS ●</li> <li>HEATING ●</li> <li>COOLING ●</li> <li>FAN ●</li> <li>HUMIDIFIER ●</li> <li>DEHUMIDIFIER ●</li> <li>VENTILATION ●</li> <li>AIR CLEANING ●</li> </ul>	<b>POWER/STATUS</b>	On solid during normal operation. Flashes when connection to the thermostat is lost and at power-up while the thermostat connection is being established.
	<b>HEATING</b>	On when heating outputs are active.
	<b>COOLING</b>	On when cooling outputs are active.
	<b>FAN</b>	On when fan output is active.
	<b>HUMIDIFIER</b>	On when humidifier output is active.
	<b>DEHUMIDIFIER</b>	On when dehumidifier output is active.
	<b>VENTILATION</b>	On when ventilation output is active.
<b>AIR CLEANING</b>	On when air cleaner output is active.	

## THERMOSTAT FEATURES

- Remote access and control over Wi-Fi.
- Indoor air quality control.
  - Humidification automatic or manual control.
  - Dehumidification.
  - Event-Based™ air cleaning.
  - Ventilation with temperature and humidity limits.
- Temperature control.
- Heat Blast® raises the room temperature 3°F to 5°F.
- One touch Away.
- Support for optional wireless outdoor temperature sensor.
- Large touch screen with adjustable backlight.
- 7 day programmability.
- Displays room temperature, room humidity, temperature setting, and optional outdoor temperature.
- Air filter, humidifier, dehumidifier, and HVAC service reminders.
- Programmable fan control with fan circulation mode.
- Easy to use temperature control can override program schedule at any time.
- Progressive recovery ensures proper temperature at the start of a program event.
- Built in compressor protection prevents damage to your equipment.
- System test mode.

## TROUBLESHOOTING

### DISPLAY IS BLANK

If Power LED is not illuminated at the equipment control module check the following:

- Check circuit breaker and reset if necessary.
- Make sure power switch at heating & cooling system is on.
- Make sure furnace door is closed securely.

### HEATING SYSTEM DOES NOT RESPOND ("HEATING" APPEARS ON SCREEN)

- Check for 24VAC at the equipment on the secondary side of the transformer between power and common. If voltage is not present, check the heating equipment to find the cause of the problem.
- Check for 24VAC between the heat terminal (W) and the transformer common. If 24VAC is present, the thermostat is functional. Check the heating equipment to find the cause of the problem.
- Check for loose or broken wires between the thermostat and the heating equipment.

### COOLING SYSTEM DOES NOT RESPOND ("COOLING" APPEARS ON SCREEN)

- Check for 24VAC at the equipment on the secondary side of the transformer between power and common. If voltage is not present, check the cooling equipment to find the cause of the problem.
- Check for 24VAC between the cooling terminal (Y) and the transformer common. If 24VAC is present, the thermostat is functional. Check the cooling system to find the cause of the problem.
- Check for loose or broken wires between the thermostat and the cooling equipment.

### FAN DOES NOT TURN ON IN A CALL FOR HEAT

- Check Installer Setting **Fan Control In Heating / Heat Pump Auxiliary Type**, to make sure the fan control is properly set to match the type of system.

### HEAT PUMP ISSUES COOL AIR IN HEAT MODE, OR WARM AIR IN COOL MODE

- Check wiring at the terminal block to confirm the reversing valve is connected to the proper terminal. O is active in cooling and B is active in heating.

### HEAT/COOL BOTH ON AT SAME TIME

- Check Installer Setting **Equipment Type**, to make sure it is set to match the installed heating/cooling equipment.
- Check to make sure heating and cooling wires are not shorted together.

### HEATING EQUIPMENT IS RUNNING IN COOL MODE

- Check Installer Setting **Equipment Type**, to make sure it is set to match the installed heating/cooling equipment.

### "HEATING" IS NOT DISPLAYED

- Check Installer Setting **Control Setup** is set correctly.
- Change the System Mode to **Heat**, and set the temperature level above the current room temperature.

### "COOLING" IS NOT DISPLAYED

- Check Installer Setting Control Setup is set correctly.
- Change the System Mode to **Cool**, and set the temperature level below the current room temperature.

# SPECIFICATIONS

ENVIRONMENT	
Temperature (shipping)	-30° to 150°F (-34° to 65°C)
Temperature thermostat (operating)	32° to 120°F (0° to 48°C)
Temperature equipment control module (operating)	32° to 158°F (0° to 70°C)
Relative humidity	Operating: 5% to 90% R.H. (non-condensing)

ELECTRICAL	
Operating voltage	24VAC (18-30VAC)
Current	Maximum: 2.5A (total), 1.0A (single output) Maximum surge current: 5A

CONTROL	
Outdoor, Remote, Leaving and Return temperature sensor	Maximum distance: 300 feet
Room temperature measurement	Display range: 32° to 99°F (0° to 40°C)
Return and Leaving temperature measurement	Display range: -40° to 160°F (-40° to 71°C)
Outdoor temperature measurement	Display range: -40° to 130°F (-40° to 55°C)
Setpoint temperature range	Heat: 40° to 90°F (4° to 32°C) Cool: 50° to 99°F (10° to 37°C)
Setpoint humidity range	Humidification: 10% to 50% R.H. Dehumidification: 40% to 90% R.H.

B2206592E • 61001172 • 6.22

© 2022 AprilAire | [aprilairpartners.com](http://aprilairpartners.com) | 800.334.6011

U.S. Patent Numbers 8,146,376, 8,596,078 and other patents pending.

AprilAire reserves the right to change specifications without notice.

