



# Model 8820 Touch Screen Wi-Fi Automation Thermostat with Integrated Indoor Air Quality Solutions



## Safety & Installation Instructions

**READ AND SAVE THESE INSTRUCTIONS**

### TABLE OF CONTENTS

#### WI-FI SETUP

Wi-Fi Setup ..... 2

#### INSTALLATION

Installation location recommendations ..... 3  
Outdoor temperature sensor (included) ..... 3  
Remote temperature sensor (optional) ..... 4  
Thermostat mounting ..... 4  
Power & reset options ..... 5  
Wiring terminal ..... 5

#### WIRING DIAGRAMS

Conventional heat/cool single transformer ..... 6  
Conventional heat/cool two transformer ..... 6  
Heat pump single transformer ..... 6  
Heat pump two transformer ..... 6  
Indoor Air Quality equipment – dehumidifier ..... 7  
Indoor Air Quality equipment – humidifier ..... 7  
Indoor Air Quality equipment – ventilation ..... 7  
Support module ..... 7

#### SETUP & TESTING

Equipment type selection switch (SW1) ..... 8  
Installer setup menu ..... 8  
Change system settings ..... 8  
Thermostat installer system settings table ..... 9-10  
Indoor Air Quality system settings tables ..... 11-15  
    Air cleaning system settings table ..... 11  
    Humidifier system settings table ..... 12  
    Dehumidifier system settings table ..... 13  
    Ventilation system settings table ..... 14-15  
Removal of Indoor Air Quality control buttons ..... 16  
System test menu ..... 16-17  
System test tables ..... 18-19

#### REFERENCES

Quick reference to controls & display ..... 20  
Troubleshooting ..... 21-22  
Error codes ..... 22  
Thermostat features ..... 23  
Specifications ..... 23

## WI-FI SETUP

To connect the 8820 thermostat to a Wi-Fi network follow the steps below.

**Note:** You will need a computer or mobile device with Wi-Fi and a web browser.

### STEP 1

#### Verify the thermostat is in Wi-Fi Connection Mode.

The thermostat by default will be in Wi-Fi Connection Mode. To confirm that the thermostat is in Wi-Fi Connection Mode, verify that the radio bars on the thermostat are strobing as shown below.



**Note:** If the thermostat is not in Wi-Fi Connection Mode, refer to the Owner's Manual for instructions on clearing the Wi-Fi settings.

### STEP 2

#### Connect to the thermostat using a computer or mobile device.

On your computer or mobile device, scan for available networks. The thermostat should appear as APRILAIRE8820 followed by a unique identifier, corresponding to the last 6 digits of the MAC address. Connect to the thermostat you want to configure.

If you are installing multiple thermostats, the MAC address of each thermostat will be displayed in the message center on the display of the thermostat. The MAC address can also be found by removing the cover on the front of the thermostat.

### STEP 3

#### Configure the thermostat to connect to the Wi-Fi network.

Open a web browser on your computer or mobile device. In the browser enter:

<http://192.168.1.99/index.html>

In the web browser interface select the network you want to connect the thermostat to, and enter the network's security credentials.

### STEP 4

#### Verify the thermostat is connected to the Wi-Fi network.

Once all the required information is entered in the web browser interface, the thermostat will connect to the Wi-Fi network you selected. After the thermostat is connected to the Wi-Fi network, the thermostat will display the radio bars based on the Wi-Fi signal strength. If the radio bars are not displaying the signal strength, refer to Troubleshooting Wi-Fi Connection on page 22.

**Note:** If you are not using the thermostat with a home automation system, but are instead using an Aprilaire account to communicate with the thermostat, Automation Enable must be set to Aprilaire Cloud in the installer setup menu, refer to pages 8 & 9. Go to [my.aprilaire.com](http://my.aprilaire.com) and refer to **Wi-Fi Thermostat App User Guide** and then **StartUp** for instructions on connecting to Wi-Fi and registering to an Aprilaire account.

## INSTALLATION

### INSTALLATION LOCATION RECOMMENDATIONS

#### Thermostat should be mounted:

- On an interior wall, in a frequently occupied space.
- Approximately 5' above floor.
- At least 18" from outside wall.
- Thermostat can be mounted to a vertical junction box.

#### Do not mount thermostat:

- Behind doors, in corners or other dead air spaces.
- In direct sunlight, near lighting fixtures, or other appliances that give off heat.
- On an outside or unconditioned area wall.
- In the flow of a supply register, in stairwells, or near outside doors.
- On a wall with concealed pipes or ductwork.

### OUTDOOR TEMPERATURE SENSOR (INCLUDED)

Outdoor temperature can be measured by attaching the included 8052 sensor to the S1 and S2 terminals. The outdoor sensor must be enabled in the installer setup menu.

#### Heat pump models can use the outdoor temperature to effectively utilize the heat pump:

- When the outdoor temperature is less than the Low Balance Point, the heat pump will be locked out and only auxiliary heating will be used to provide heating.
- When the outdoor temperature is higher than the High Balance Point, the auxiliary heating will be locked out and only the heat pump will be used to provide heating.

#### Indoor Air Quality functions can use the outdoor temperature sensor to:

- Control humidification setpoint based on outdoor temperature to prevent condensation.
- Lock out humidification for temperatures over 60°F or below -30°F.
- Lock out ventilation based on high and/or low outdoor temperatures.
- Display outdoor temperature on thermostat.

#### Outdoor temperature sensor should be mounted:

- On side of building out of direct sunlight (north side recommended).
- Above snow line.
- At least 3' away from exhaust vents and condensing lines.
- Using less than 300' of wire.
- Do not route wires along 120 VAC lines.

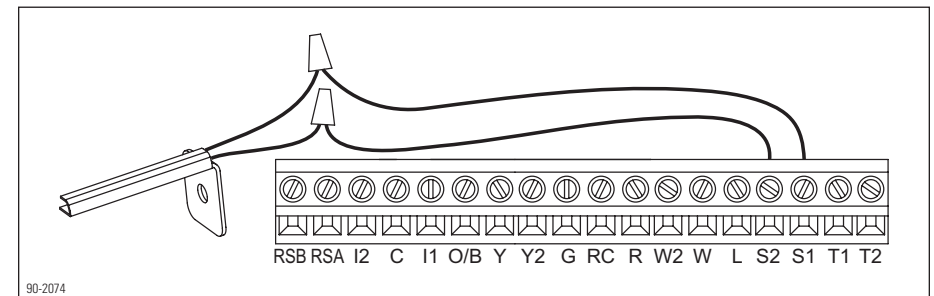

## INSTALLATION

### REMOTE TEMPERATURE SENSOR (OPTIONAL)

A remote temperature sensor can be used for control if the thermostat is to be mounted in a concealed location or a remote sensor can be averaged with the thermostat sensor to control a large space. An 8051 flush mount or 8053 surface mount remote temperature sensor can be attached to the T1 and T2 terminals and mounted in a recommended area. The remote sensor must be enabled in the installer setup menu, and once enabled will override or be averaged with the thermostat's internal temperature sensor, based on the setting.

#### Remote temperature sensor should be mounted:

- On an interior wall, in a frequently occupied space.
- Approximately 5' above floor.
- At least 18" from outside wall.
- Using less than 300' of wire.

#### Do not mount remote sensor:

- Behind doors, in corners or other dead air spaces.
- In direct sunlight, near lighting fixtures, or other appliances that give off heat.
- On an outside or unconditioned area wall.
- In the flow of a supply register, in stairwells, or near outside doors.
- On a wall with concealed pipes or ductwork.
- Near 120 VAC lines.

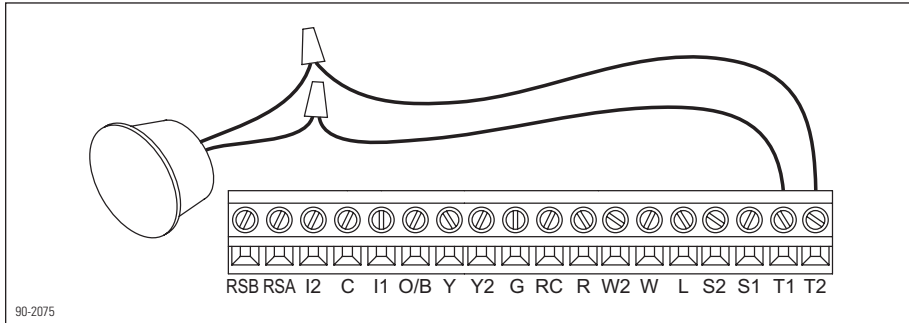

### THERMOSTAT MOUNTING

1. Remove the rear mounting plate from the thermostat.
2. Pull wires through the opening on the back of the rear mounting plate.
3. Position and level the mounting plate of the thermostat on wall and mark the hole locations with a pencil.
4. Drill 1/4" holes and insert supplied anchors (drywall only).
5. Place mounting plate over anchors, insert and tighten screws.
6. Seal wire entry holes to prevent drafts affecting temperature readings.

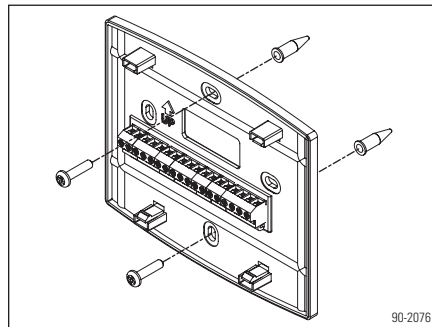

## INSTALLATION

### POWER & RESET OPTIONS

The thermostat is powered from 24VAC. In the case of power loss the thermostat will maintain the clock for 24 hours. The thermostat has a memory backup that saves the thermostat settings in case of power interruption.

The reset button located under the cover on the front of the thermostat can be used to reset the thermostat to factory defaults. The Installer System Settings will also be set to the default settings.

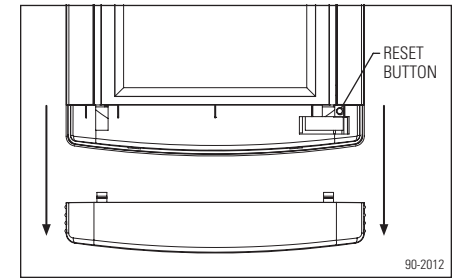

### WIRING TERMINAL

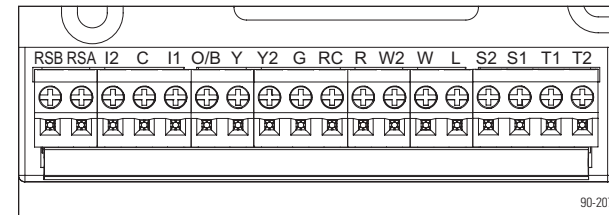

#### Wire specifications:

18-24 gauge thermostat wire

#### Installation notes:

- Ensure power at the HVAC equipment is off.
- Loosen screw terminals, insert stripped wire and re-tighten.
- Push the excess wire back into the opening and plug the wall opening to prevent drafts.

**RSB & RSA** – Model 8081 or 8082 Support Module communication

**I1 & I2** – Indoor Air Quality control output

**C** – Common

**O/B** – Reversing valve

**Y** – First stage cooling (conventional) / First stage compressor (heat pump)

**Y2** – Second stage cooling (conventional) / Second stage compressor (heat pump)

**G** – Fan

**RC** – 24VAC supply cooling<sup>1</sup>

**R** – 24VAC supply heating<sup>1</sup>

**W2** – Second stage heat (conventional) / Second stage auxiliary (heat pump)

**W** – First stage heat (conventional) / First stage auxiliary (heat pump)

**L** – System fault indicator (optional) (heat pump only)

**S1 & S2** – outdoor temperature sensor (included)

**T1 & T2** – remote temperature sensor (optional)

<sup>1</sup>Jumper between RC & R is used in single transformer systems (see wiring diagrams).

# INSTALLATION

## CONVENTIONAL HEAT/COOL WIRING DIAGRAMS

### SINGLE TRANSFORMER (USE JUMPER WIRE)

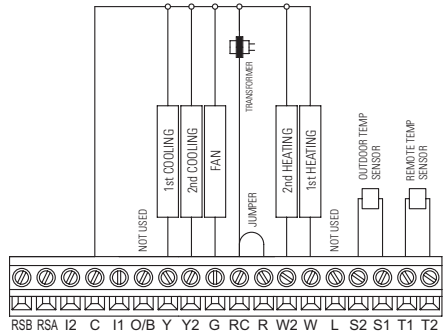

90-2078

### TWO TRANSFORMERS (REMOVE JUMPER WIRE)

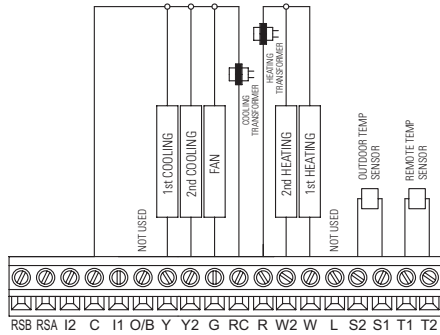

90-2080

## HEAT PUMP WIRING DIAGRAMS

### SINGLE TRANSFORMER (USE JUMPER WIRE)

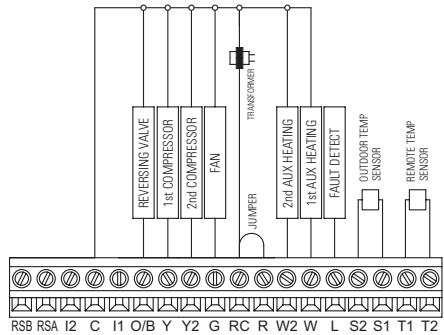

90-2079

### TWO TRANSFORMERS (REMOVE JUMPER WIRE)

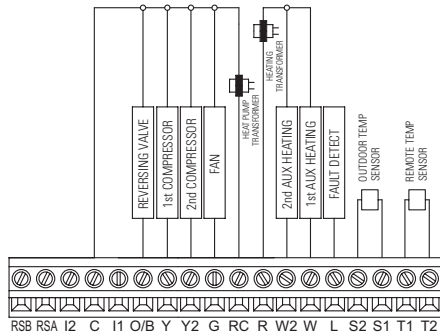

90-2080

# INSTALLATION

## INDOOR AIR QUALITY EQUIPMENT WIRING DIAGRAMS

### DEHUMIDIFIER WIRING

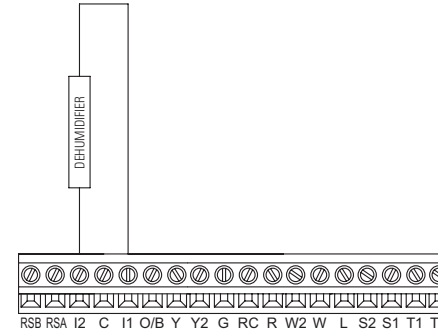

90-2080

### HUMIDIFIER WIRING

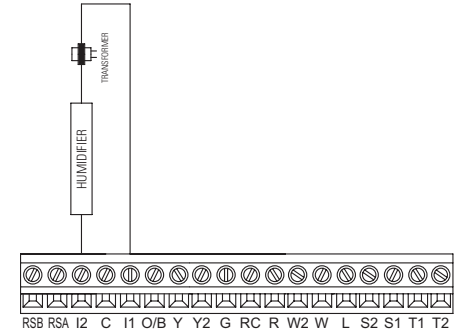

90-2080

### VENTILATION WIRING

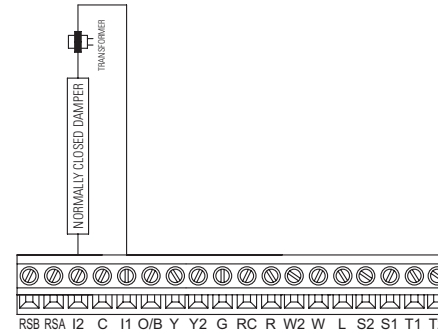

90-2080

**Note:** The I1/I2 output is a dry contact closure. The humidifier wiring diagram assumes the control is powering a solenoid valve. The dehumidifier wiring diagram is for a normally open dry contact input. The ventilation diagram assumes the control is for a normally closed damper. Refer to the individual humidifier, dehumidifier or ventilation installation instructions for product specific wiring details.

## SUPPORT MODULE WIRING DIAGRAM

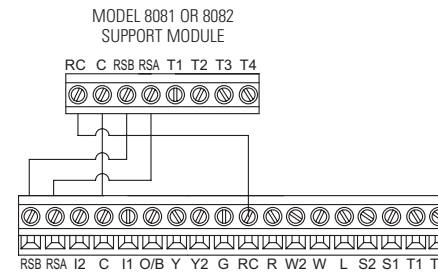

90-2080

**Note:** Up to four Support Modules can be wired to the thermostat. Support Modules should be wired with CAT-5 wire. The total length of wire for all support modules should not exceed 1000 feet.

## SETUP & TESTING

### EQUIPMENT TYPE SELECTION SWITCH (SW1)

This thermostat has the option of being used in heat pump or heat/cool systems. Switch SW1 located on the back of the thermostat's face is used to select this option. This setting is displayed in the Installer System Settings under Equipment Type.

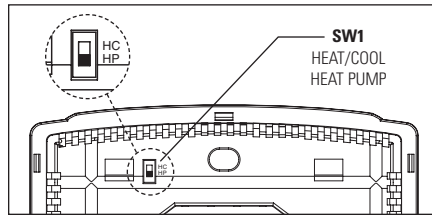

### INSTALLER SETUP MENU

#### HOW TO ENTER THE INSTALLER SETUP MENU AND SELECT EQUIPMENT TO SETUP:

In the Installer Setup menu, Thermostat or Indoor Air Quality (IAQ) setup can be selected. If IAQ setup is selected, the user can then select to set up Air Cleaning, Humidification, Dehumidification or Ventilation.

Press **[MODE]** to set system to OFF.

Press **[MENU]** to enter main menu.

Press and hold **[SETUP]** for seven seconds, **[INSTALL SETUP]** appears.

Press **[INSTALL SETUP]** to enter installer setup menu.

Press **▲** or **▼** to adjust the option.

Press **[MENU]** to exit.

Press **[NEXT]** to select option.

**Note:** If IAQ is selected prior to performing thermostat setup, the Installer System Setting for Outdoor Sensor will be presented prior to entering IAQ setup.

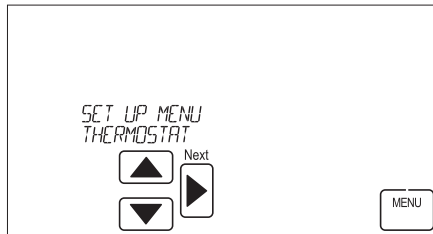

### CHANGE SYSTEM SETTINGS

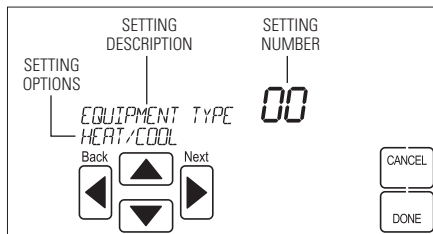

Press **[NEXT]** or **[BACK]** to page through the settings.

Press **▲** or **▼** to adjust the setting.

Press **[DONE]** to save and exit, or **[CANCEL]** to exit without saving.

The thermostat will discard changes and exit if nothing is pressed within 60 seconds.

To reset the Installer System Settings to the default settings, reset the thermostat by pressing the **[RESET]** button for 5 seconds.

## SETUP & TESTING

### THERMOSTAT INSTALLER SYSTEM SETTINGS TABLE

The following table contains the system settings and their details. Default settings are shown in **bold**. Some settings are only available dependent upon the value of other settings.

System setting	Description	Factory default setting (bold) and setting range
00. Automation Enable	Selects if the thermostat connects with an automation system or an Aprilaire account.	0: Aprilaire Cloud <b>1: Automation System</b>
01. Equipment Type	Equipment type set by SW1.	<b>Heat/Cool</b> Heat Pump
02. Temperature Scale	Set the thermostat to Fahrenheit or Celsius mode.	<b>Fahrenheit</b> Celsius
03. Reversing Valve	Selects O or B operation.	<b>O – On in cooling</b> B – On in heating
04. Control Setup	Used to lockout heating or cooling outputs. <b>Note:</b> Only available if Equipment Type is set to Heat/Cool.	<b>Heat and Cool</b> Heat Only Cool Only
05. Heat/Cool: Cooling Stages Heat Pump: Compressor Stages	Heat/Cool: Number of Cooling Stages. Heat Pump: Number of Compressor Stages.	<b>One</b> Two
06. Heat/Cool: Heating Stages Heat Pump: Aux Heat Stages	Heat/Cool: Number of Heat Stages. Heat Pump: Number of Auxiliary Heat Stages.	<b>One</b> Two
07. Heat/Cool: Fan Control in Heating Heat Pump: Auxiliary Equipment Type	Heat/Cool: Determines if the thermostat or equipment controls the fan in heating. Heat Pump: Auxiliary Equipment type.	<b>Gas/Oil Heat</b> (equipment controls fan) Electric Heat (thermostat controls fan)
08. Extended Fan – Heat	Extends fan operation after heat call ends.	<b>Disable</b> Enable (90 second extension)
09. Extended Fan – Cool	Extends fan operation after cool call ends.	<b>Disable</b> Enable (90 second extension)
10. Temperature Sensor Offset	Field adjustment of controlling temperature sensor(s).	<b>0°</b> (no offset applied) -4°F to +4°F (-2°C to +2°C)
11. Humidity Offset	Field adjustment of internal RH sensor.	<b>0</b> (no offset applied) -5% to +5%
12. Auto Changeover	Enable or disable Auto Changeover mode.	<b>Disable</b> Enable
13. Deadband	Auto Changeover mode deadband.	<b>3°F (1.5°C)</b> 2°F to 9°F (1°C to 4.5°C)
14. Remote Sensor	Select if remote sensor is attached, and if it is attached, if it is the primary control or averaged with the built-in sensor. If the remote sensor is the primary control it can be configured to use the built-in sensor as a back-up sensor.	<b>Not installed</b> Control no backup Control with built-in backup Average with thermostat built-in sensor
15. Outdoor Sensor	Selects if an outdoor temperature sensor is not installed, a wired sensor is installed, or the outdoor temperature is provided by the automation system. <b>Note:</b> Automation is only available if Automation Enable is set to Automation System.	<b>Not installed</b> Installed Automation
18. Compressor Min Off Time	Minimum off time for compressor protection.	<b>5 minutes</b> 1 to 5 minutes
19. Heating Min Off Time	Minimum off time for heating.	<b>2 minutes</b> 1 to 5 minutes
20. Equipment Min On Time	Minimum on time for heating and cooling.	<b>2 minutes</b> 1 to 5 minutes
21. Auto Changeover Time	Minimum time between heating and cooling calls.	<b>4 minutes</b> 1 to 5 minutes

## SETUP & TESTING

### HVAC INSTALLER SYSTEM SETTINGS TABLE (CONTINUED)

System setting	Description	Factory default setting (bold) and setting range
22. First Stage Differential	First stage differential.	<b>1°F (0.5°C)</b> 1°F to 9°F (0.5°C to 4.5°C)
23. Second Stage Differential	Second stage differential.	<b>1°F (0.5°C)</b> 1°F to 9°F (0.5°C to 4.5°C)
24. Third Stage Differential	Third stage differential.	<b>1°F (0.5°C)</b> 1°F to 9°F (0.5°C to 4.5°C)
25. Fourth Stage Differential	Fourth stage differential.	<b>1°F (0.5°C)</b> 1°F to 9°F (0.5°C to 4.5°C)
26. Away	Enables the Away feature. The Away feature allows the automation system or Aprilaire mobile and web apps to use a single button press to set the thermostat to a predefined setpoint(s). The thermostat will hold the setpoint(s) until Away is canceled with the automation system or app or at the thermostat.	<b>Disable</b> Enable
27. Heat Blast	Enables the Heat Blast feature.	<b>Disable</b> Enable
28. Blast Offset	Amount of heating when Heat Blast is initiated.	<b>3°F (1.5°C)</b> 3°F to 5°F (1.5°C to 2.5°C)
37. Stage Rate	Accumulation of equipment run time in equipment staging determination. 1 = more rapid staging of equipment (comfort). 5 = slower staging of equipment (economy).	<b>2</b> 1 to 5 or "OFF" to ignore accumulated run time.
38. Progressive Recovery	Enable or disable progressive recovery.	<b>Disable</b> Enable
39. Low Balance Point	Outdoor temperature low balance point. <b>Note:</b> This option is only available if the thermostat is set to Heat Pump and Outdoor Sensor is set to Installed or Automation.	<b>20°F or -8°C</b> 0°F to 60°F (-18°C to 12°C) or OFF to ignore LBP
40. High Balance Point	Outdoor temperature high balance point. <b>Note:</b> This option is only available if the thermostat is set to Heat Pump and Outdoor Sensor is set to Installed or Automation.	<b>65°F or 14.5°C</b> 0°F to 80°F (-18°C to 22°C) or OFF to ignore HBP
41. Program Format	Enables the 7-day program.	<b>7-Day</b> Non-Prog
42. Reset Service Reminders	Clears the Air Filter, Dehumidifier, Fresh Air, and HVAC service reminders if they are active and resets the start date to the current date. Clears the Change Water Panel reminder if it is active. If the reminder is set to Timed, the clock will be reset.	<b>No</b> Yes
43. HVAC Service Reminder	The period for displaying the "HVAC Service Reminder" message.	<b>Off</b> 1 to 12 months or "Off" to disable
44. Constant Backlight	Enable constant, low intensity backlight.	<b>Disable</b> Enable
45. Backlight Intensity	Set the active backlight intensity. <b>Note:</b> The minimum setting is 40% when Constant Backlight is enabled.	<b>100 Percent</b> 0 to 100 Percent
51. Support Module Controlling Temp Sensors	Sets the number of controlling support module temperature sensors.	<b>NONE</b> 1 to 8
52. Support Module Controlling RH Sensors	Sets the number of controlling support module humidity sensors.	<b>NONE</b> 1 to 4
53. Display Monitor Support Module Sensor	Selects if the temperature or humidity values from support modules that are configured for monitoring are displayed in the message center of the thermostat.	<b>No</b> Yes

## SETUP & TESTING

### INDOOR AIR QUALITY SYSTEM SETTINGS TABLES

The following tables contain the Indoor Air Quality system settings and their details. Default settings are shown in **bold**. Some settings are only present dependent upon the value of other settings.

The use of the included outdoor temperature sensor (recommended) enables additional Indoor Air Quality functionality. If the outdoor temperature sensor was not enabled in the thermostat system settings, thermostat system setting 15, outdoor sensor, will be presented prior to entering the Indoor Air Quality system settings.

Please refer to the Model 8820 Owner's Manual for further information about thermostat features.

#### Air Cleaning System Settings Table

System setting	Description	Factory default setting (bold) and setting range
Air Cleaner Installed	Selects if an air cleaner is installed. (If set to no, no other air cleaning settings will be available.)	<b>No</b> Yes
Change Air Filter Reminder	The period for displaying the "Change Air Filter" message.	<b>Off</b> 1 to 12 months or "Off" to disable

## SETUP & TESTING

### Humidifier System Settings Table

**Note:** A humidifier can only be installed if ventilation is not installed and Dehumidifier Control is not set to Whole Home or AC w/IAQ Output.

System setting	Description	Factory default setting (bold) and setting range
Humidifier Installed	Selects if a humidifier is installed. <b>Yes/On HVAC</b> is used for applications where the humidifier is installed on the HVAC duct. <b>Yes/Standalone</b> is used for application where the humidifier is independent of the HVAC system. (If set to no, no other humidifier settings will be available.)	<b>No</b> Yes/On HVAC Yes/Standalone
Humidifier Mode	Selects auto or manual mode. Auto mode controls humidity based on the humidity setting and outdoor temperature. Manual mode controls humidity based on the %RH setpoint. (Auto mode is only available if outdoor sensor is set to Installed or Automation.)	<b>Auto</b> Manual
Humidity Setpoint Deadband	Selects the minimum difference between the humidifier and dehumidifier setpoints. (Only available if a humidifier is installed and dehumidifier control is set to air conditioner. Available in both set-ups.)	<b>10 Percent RH</b> 10 to 20 Percent RH
Humidifier Operation	Selects when humidification is allowed to occur relative to heating and fan operation. Without Fan allows humidification to occur without the HVAC fan. This option should only be used when the humidifier is independent of the HVAC system. Note: <b>Without Fan</b> is only available when <b>Humidifier Installed</b> is set to <b>Yes/Standalone</b> .	Heat Only Heat or Fan <b>Forces Fan</b> Without Fan
<b>▲ CAUTION:</b> When <b>Humidifier Operation</b> is set to <b>Without Fan</b> the thermostat will turn on humidification without energizing the HVAC fan. Do not select this option when the humidifier is installed on the HVAC duct. Without airflow moisture can accumulate in the duct resulting in significant damage.		
Change Water Panel Reminder	Selects the when the "Change Water Panel" message is displayed.	<b>Off</b> 1 Per Season 2 Per Season 300 Hours 600 Hours
Reminder Month (Change Water Panel Reminder set to 1 per Season)	Change Water Panel Reminder set to 1 per Season: Determines the month the "Change Water Panel" message is displayed.	<b>October</b> November December
First Reminder Month (Change Water Panel Reminder set to 2 per Season)	Change Water Panel Reminder set to 2 per Season: Determines the first month the "Change Water Panel" message is displayed.	January February March April May June July August September
Second Reminder Start Month	Determines the second month the "Change Water Panel" message is displayed. (Only available when Change Water Panel Reminder set to 2 per Season.)	October November December <b>January</b> February March April May June July August September

## SETUP & TESTING

### Dehumidifier System Settings Table

**Note:** Dehumidifier Control can only be set to Whole Home or AC w/IAQ Output if ventilation and humidification are not installed.

System setting	Description	Factory default setting (bold) and setting range
Dehumidifier Control	Selects method of dehumidification. If set to None, no other dehumidifier settings will be available. If dehumidification is done with the air conditioner, using the option of AC w/IAQ Output will cause the IAQ output to be active when overcooling for dehumidification. This can be used if the HVAC equipment has a dedicated input to slow the fan during cooling to maximize dehumidification.	<b>None</b> (no dehumidification installed) Whole Home Air Conditioner AC w/IAQ Output
Humidity Setpoint Deadband	Select the minimum difference between the humidifier and dehumidifier setpoints. (Only available if a humidifier is installed and Dehumidifier Control is set to Air Conditioner. Available in both set-ups.)	<b>10 Percent RH</b> 10 to 20 Percent RH
Lockout Dehumidifier During Cooling	Selects if dehumidification is disabled during a cooling call. (Only available if Dehumidifier Control is set to Whole Home.)	No <b>Yes</b>
Dehumidifier Forces Fan	Select if dehumidification can turn on the fan. (Only available if Dehumidifier Control is set to Whole Home.)	No <b>Yes</b>
Dehumidifier Service Reminder	The period for displaying the "Dehum Service Reminder" message. (Only available if Dehumidifier Control is set to Whole Home.)	<b>Off</b> 1 to 12 months or "Off" to disable
Dehumidifier Overcooling Limit	Selects the amount of overcooling that can occur for dehumidification. (Only available if Dehumidifier Control is set to Air Conditioner or AC w/IAQ Output.)	<b>3°F (1.5°C)</b> 1°F to 3°F (0.5°C to 1.5°C)
Dehumidify in Vacation Mode	Selects if dehumidification with the air conditioner is done in Vacation Mode. (Only available if Dehumidifier Control is set to Air Conditioner or AC w/IAQ Output.)	No Yes
Vacation Dehumidifier Low Temp Limit	Sets the lowest temperature the air conditioner will cool to, to meet RH setpoint in Vacation Mode. (Only available if Dehumidifier Control is set to Air Conditioner or AC w/IAQ Output.)	<b>75°F (23.5°C)</b> 70°F to 85°F (21°C to 28.5°C)

## SETUP & TESTING

### Ventilation System Settings Table

**Note:** Ventilation can only be installed if humidification is not installed and Dehumidifier Control is not set to Whole Home or AC w/IAQ Output.

System setting	Description	Factory default setting (bold) and setting range
Fresh Air Vent Installed	Selects if ventilation is installed. (If set to No, no other ventilation settings will be available.)	<b>No</b> Yes
Fresh Air Setup Type	Selects if ventilation is configured through the Code setup or Comfort. Comfort setup has more lockout options. Code setting ensures missed lockout time is made up.	<b>Comfort</b> Code
Number of Bedrooms	Selects the number of bedrooms to be used for the Calculated Minutes per Hour.	<b>3 Bedrooms</b> 1 to 10 Bedrooms
Home Size	Selects the size of the home to be used for the Calculated Minutes per Hour.	<b>2500 SQ FT</b> 500 to 7500 SQ FT
Measured CFM	Selects the ventilation CFM to be used for the Calculated Minutes per Hour.	<b>110 CFM</b> 30 to 250 CFM
Calculated Minutes per Hour	Displays the Fresh Air Time calculated.	<b>None</b> Range 6 to 60 Minutes
Override	Manual adjustment of Calculated Minutes per Hour.	<b>(Calculated Minutes per Hour)</b> Range 6 to 60 Minutes
Enable High Vent RH Limit	Selects if ventilation is disabled if the indoor RH exceeds the indoor RH limit. (Only available if Fresh Air Setup is set to Comfort.)	<b>Yes</b> No
High Vent RH Limit	Sets the ventilation indoor RH lockout limit. (Only available if Enable High Vent RH Limit is set to Yes.)	<b>55%</b> 45% to 70%
Enable Low Vent RH Limit	Selects if ventilation is disabled if the indoor RH exceeds the indoor RH limit. (Only available if Fresh Air Setup is set to Comfort.)	<b>No</b> Yes
Low Vent RH Limit	Sets the ventilation indoor RH lockout limit. (Only available if Enable Low Vent RH Limit is set to Yes.)	<b>20%</b> 10% to 30%
Enable High Vent Temperature Limit	Enables high ventilation temperature lockout limit. (Only available if Outdoor Sensor is set to Installed or Automation.)	<b>No</b> Yes
High Vent Temperature Limit	Sets high ventilation temperature lockout limit. (Only available if Enable High Vent Temperature Limit is set to Yes.)	<b>100°F (38°C)</b> 85°F to 105°F (29°C to 41°C)
Enable Low Vent Temperature Limit	Enables low ventilation temperature lockout limit. (Only available if Outdoor Sensor is set to Installed or Automation.)	<b>No</b> Yes

## SETUP & TESTING

System setting	Description	Factory default setting (bold) and setting range
Low Vent Temperature Limit	Sets low ventilation temperature lockout limit. (Only available if Enable Low Vent Temperature Limit is set to Yes.)	<b>10°F (-12°C)</b> -10°F to 40°F (-24°C to 6°C)
HVAC Fan with Vent	Selects if ventilation forces the fan on. (Yes with high and low limits is only available if Outdoor Sensor is set to Installed or Automation.)	<b>Yes</b> Yes with high and low limits No
Enable High Mixing Temperature	Enables high mixing temperature. (Only available is HVAC Fan with Vent is set to Yes with high and low limits.)	<b>No</b> Yes
High Mixing Temperature	Sets the high mixing temperature. (Only available if Enable High Mixing Temperature is set to Yes.)	<b>80°F or (26°C)</b> 60°F to 105°F (14°C to 41°C)
Enable Low Mixing Temperature	Enables low mixing temperature. (Only available is HVAC Fan with Vent is set to Yes with high and low limits.)	<b>No</b> Yes
Low Mixing Temperature	Sets the Low mixing temperature. (Only available if Enable Low Mixing Temperature is set to Yes.)	<b>40°F (6°C)</b> 0°F to 50°F (-18°C to 12°C)
Fresh Air Service Reminder	The period for displaying the "SERVICE FRESH AIR" message.	<b>OFF</b> 1 to 12 months or "OFF" to disable

**Note:** Refer to manuals for humidifier, dehumidifier, air cleaner, and ventilation products for recommended installation and operation.



## SETUP & TESTING

### REMOVAL OF INDOOR AIR QUALITY CONTROL BUTTONS

If any of the Indoor Air Quality control features are not installed, the corresponding button can be removed using the following procedure:

**Step 1:** Verify the specific Indoor Air Quality control feature is not installed in the Installer System Settings (see pages 11-14).

**Step 2:** From the home screen (see page 20), **press and hold** the Indoor Air Quality button you wish to remove for 7 seconds.

**Step 3:** The message center will display REMOVE BUTTON and the options of NO and YES (NO will be flashing).

**Step 4:** Press ▲ or ▼ to select YES.

**Step 5:** Press [DONE].

**Step 6:** The button is now removed.

**Note:** Once the button is removed it can be brought back by installing the corresponding Indoor Air Quality feature (see pages 11-14).

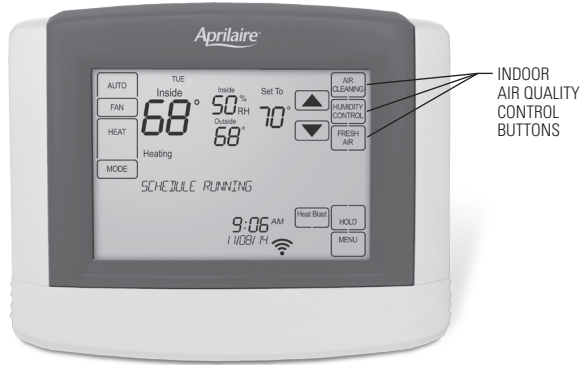

### SYSTEM TEST MENU

The system test menu is used to test a system after installation. The outputs of the thermostat can be manually activated to test their function. The instructions below show how to enter the test mode and turn outputs on and off.

#### HOW TO ENTER THE SYSTEM TEST MENU:

Press [MODE] to set system to off.

Press and hold [FAN] and [MODE] for three seconds to enter system test mode.

The first screen of the installer test displays the equipment configuration.

Press [NEXT] to enter the first installation test or [CANCEL] to exit.

#### SYSTEM TEST STEPS

- Heating equipment test
- Cooling equipment test
- Fan equipment test
- Humidification equipment test
- Dehumidification equipment test
- Ventilation equipment test

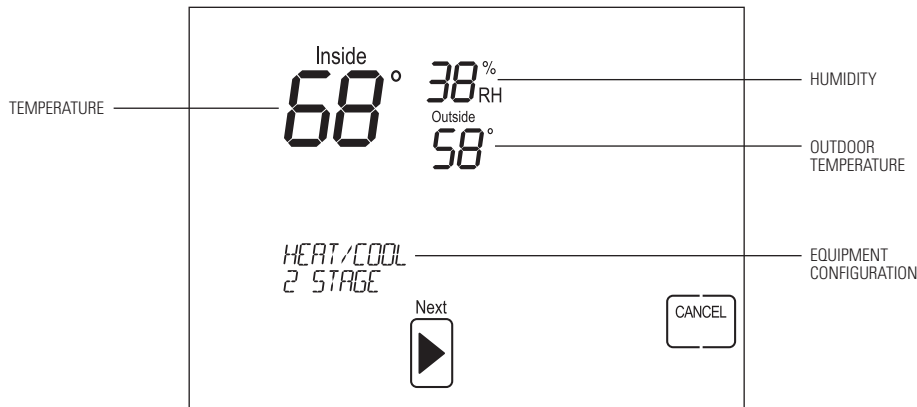

## SETUP & TESTING

### SYSTEM TEST MENU (CONTINUED)

Each equipment test will begin with the selection of turning on the output or stage as shown below.

Press ▲ or ▼ to change the selection.

Press [NEXT] to accept the selection and proceed to the next step.

If **YES** is selected, the thermostat will test the corresponding output. If **NO** is selected, the thermostat will proceed to the next step.

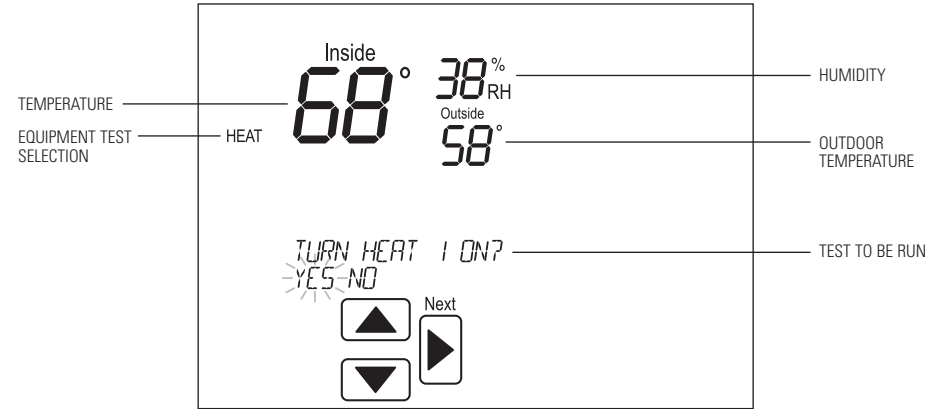

While the equipment test is active the corresponding test information will be shown.

Press [NEXT] to accept the selection and proceed to the next test selection.

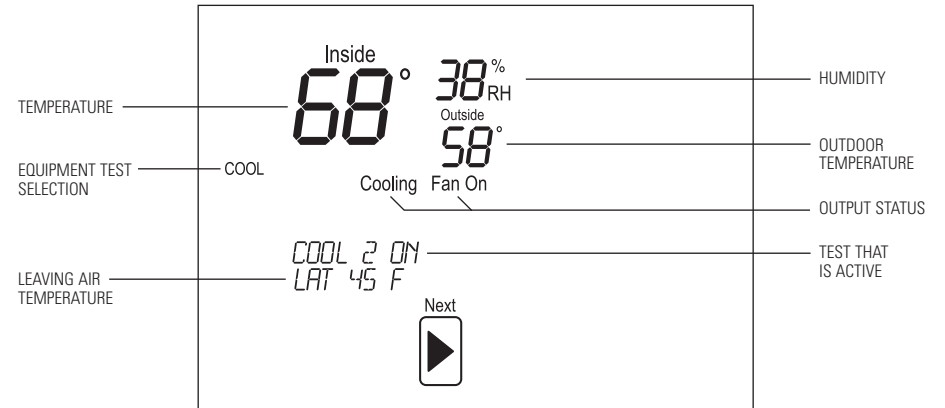

## SETUP & TESTING

### SYSTEM TEST TABLES

Heat / Cool Heating Equipment Test						
Heat Type		W	W2	Y	Y2	G
Gas	1st Stage Test	ON				
Gas	2nd Stage Test	ON	ON			
Electric	1st Stage Test	ON				ON
Electric	2nd Stage Test	ON	ON			ON

Heat Pump Heating Equipment Test (Electric Heat)									
Compressor Stages	Aux Stages		W	W2	Y	Y2	O/B set to		G
							O	B	
1	1	1st Stage Test			ON			ON	ON
1	1	2nd Stage Test	ON		ON			ON	ON
2	1	1st Stage Test			ON			ON	ON
2	1	2nd Stage Test			ON	ON		ON	ON
2	1	3rd Stage Test	ON		ON	ON		ON	ON
1	2	1st Stage Test			ON			ON	ON
1	2	2nd Stage Test	ON		ON			ON	ON
1	2	3rd Stage Test	ON	ON	ON			ON	ON
2	2	1st Stage Test			ON			ON	ON
2	2	2nd Stage Test			ON	ON		ON	ON
2	2	3rd Stage Test	ON		ON	ON		ON	ON
2	2	4th Stage Test	ON	ON	ON	ON		ON	ON

**Note:** System Variable 03, O/B operation selects O or B.

Heat Pump Heating Equipment Test (Gas Heat)									
Compressor Stages	Aux Stages		W	W2	Y	Y2	O/B set to		G
							O	B	
1	1	1st Stage Test			ON			ON	ON
1	1	2nd Stage Test	ON					ON	
2	1	1st Stage Test			ON			ON	ON
2	1	2nd Stage Test			ON	ON		ON	ON
2	1	3rd Stage Test	ON					ON	
1	2	1st Stage Test			ON			ON	ON
1	2	2nd Stage Test	ON					ON	
1	2	3rd Stage Test	ON	ON				ON	
2	2	1st Stage Test			ON			ON	ON
2	2	2nd Stage Test			ON	ON		ON	ON
2	2	3rd Stage Test	ON					ON	
2	2	4th Stage Test	ON	ON				ON	

**Note:** System Variable 03, O/B operation selects O or B.

## SETUP & TESTING

### SYSTEM TEST TABLES (CONTINUED)

Heat / Cool Cooling Equipment Test					
	W	W2	Y	Y2	G
1st Stage Test			ON		ON
2nd Stage Test			ON	ON	ON

Heat Pump Cooling Equipment Test							
	W	W2	Y	Y2	O/B set to		G
					O	B	
1st Stage Test			ON		ON		ON
2nd Stage Test			ON	ON	ON		ON

**Note:** System Variable 03, O/B operation selects O or B.

Fan Equipment Test				
W	W2	Y	Y2	G
				ON

Humidification Equipment Test	
I1/I2	G
ON	ON

Dehumidification Equipment Test	
I1/I2	G
ON	ON

Ventilation Equipment Test	
I1/I2	G
ON	ON

## QUICK REFERENCE TO CONTROLS & DISPLAY

### HOME SCREEN

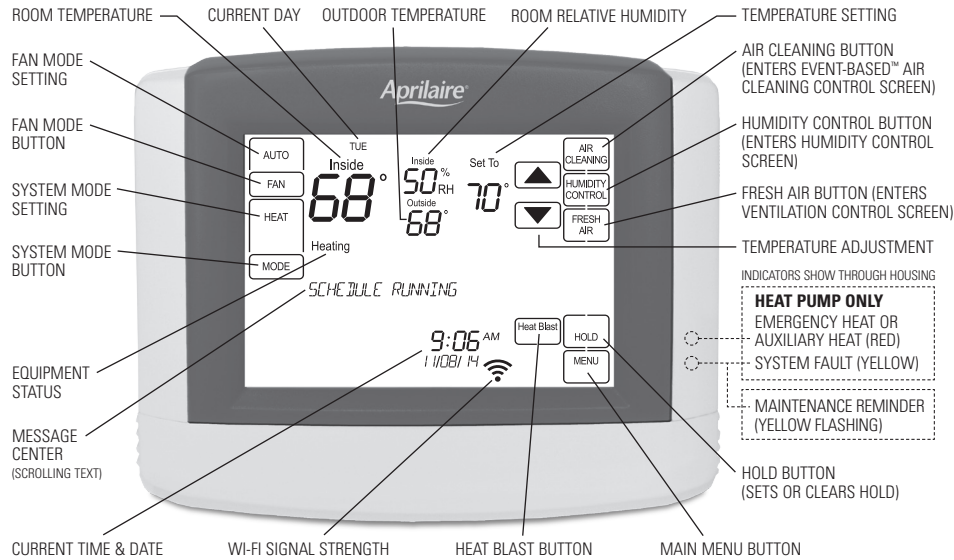

**NOTE:** BACKLIGHT IS ACTIVATED WITH FIRST BUTTON PRESS AND AUTOMATICALLY TURNS OFF.

### MAIN MENU

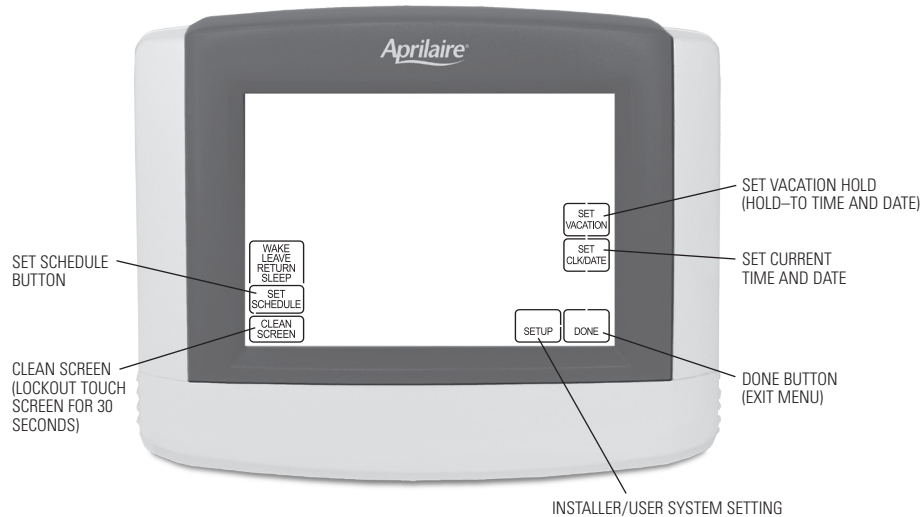

## TROUBLESHOOTING

### DISPLAY IS BLANK

- Check circuit breaker and reset if necessary.
- Make sure power switch at heating & cooling system is on.
- Make sure furnace door is closed securely.

### TEMPERATURE SETTINGS DO NOT CHANGE

Make sure heating and cooling temperatures are set to acceptable ranges:

- Heat: 40° to 90°F (4° to 32°C).
- Cool: 50° to 99°F (10° to 37°C).

### HEATING SYSTEM DOES NOT RESPOND ("HEATING" APPEARS ON SCREEN)

- Check for 24VAC at the equipment on the secondary side of the transformer between power and common. If voltage is not present, check the heating equipment to find the cause of the problem.
- Check for 24VAC between the heat terminal (W) and the transformer common. If 24VAC is present, the thermostat is functional. Check the heating equipment to find the cause of the problem.
- Check for loose or broken wires between the thermostat and the heating equipment.

### COOLING SYSTEM DOES NOT RESPOND ("COOLING" APPEARS ON SCREEN)

- Check for 24VAC at the equipment on the secondary side of the transformer between power and common. If voltage is not present, check the cooling equipment to find the cause of the problem.
- Check for 24VAC between the cooling terminal (Y) and the transformer common. If 24VAC is present, the thermostat is functional. Check the cooling system to find the cause of the problem.
- Check for loose or broken wires between the thermostat and the cooling equipment.

### FAN DOES NOT TURN ON IN A CALL FOR HEAT

- Check System Setting 07 (Fan Control), to make sure the fan control is properly set to match the type of system (see page 9).

### HEAT PUMP ISSUES COOL AIR IN HEAT MODE, OR WARM AIR IN COOL MODE

- Check System Setting 03 (O/B Operation) to make sure the reversing valve operation matches the heat pump.

### HEAT/COOL BOTH ON AT SAME TIME

- Check SW1 (Equipment Type), to make sure it is set to match the installed heating/cooling equipment (see page 8).
- Check to make sure heating and cooling wires are not shorted together.

### HEATING EQUIPMENT IS RUNNING IN COOL MODE

- Check SW1 (Equipment Type), to make sure it is set to match the installed heating/cooling equipment (see page 8).

### "HEATING" IS NOT DISPLAYED

- Check Installer System Setting number 04 (Control Setup) is set correctly.
- Change the System Mode to Heat, and set the temperature level above the current room temperature.

### "COOLING" IS NOT DISPLAYED

- Check Installer System Setting number 04 (Control Setup) is set correctly.
- Change the System Mode to Cool, and set the temperature level below the current room temperature.





### HUMIDIFIER DOES NOT OPERATE IN AUTO MODE

- Check Installer System Setting number 15 (Outdoor Sensor) is set to Installed or Automation.
- Verify that the outdoor sensor is functioning correctly or if it is set to Automation that it has not timed out. If the sensor is functioning correctly the outdoor temperature will display in the outdoor temperature location (see Home Screen on page 20 for the location).

## TROUBLESHOOTING

### TROUBLESHOOTING WI-FI CONNECTION

The Wi-Fi connection status is communicated through the use of the radio strength indicator and the message center. The table below describes the various statuses and the corresponding message and radio bar display.

Wi-Fi connection status	Radio status indicator	Message Center
Normal Operation.	Wi-Fi signal strength is indicated by the appropriate number of bars. 	No corresponding message
The thermostat Wi-Fi settings have not been entered. Refer to Wi-Fi Setup on page 2 for instructions for entering the Wi-Fi settings.	The frame is displayed and the bars cycle from 0 to 4. 	Displays the SSID of the thermostat. <b>Note:</b> The SSID will be used to identify the thermostat when using a smart device to connect the thermostat to your Wi-Fi router.
The thermostat cannot connect to the Wi-Fi router. Verify that the router is functioning properly.	The frame and all bars flash on and off. 	WiFi Connection Lost
Indicates the thermostat was not configured properly when connecting to the router. Confirm there is no IP conflict and repeat Wi-Fi setup. <b>Note:</b> If the thermostat is configured to work with an Aprilaire account this indicates that the thermostat cannot connect to the Aprilaire Cloud. Confirm that the internet connection is working.	The display will alternate between displaying the frame and all bars. 	Internet Connection Lost
There is an internal error with the thermostat Wi-Fi radio. The thermostat will continue to control the HVAC and indoor air quality control equipment, but will not be able to connect to Wi-Fi. Contact an HVAC professional for repair.	The frame will flash on and off. 	Radio Error
Wi-Fi radio turned off. Refer to the Accessing Wi-Fi Settings Menu in the Owner's Manual for information about turning the Wi-Fi radio on.	Not displayed.	WiFi Turned Off

### ERROR CODES

If the thermostat enters an error mode, all outputs are turned off. The thermostat attempts to recover every 10 minutes.

Error code	Message	Error Description
01	"SENSOR ERROR"	Open temperature sensor circuit
02		Shorted temperature sensor circuit
03	"EEPROM ERROR"	Error in permanent memory
06	"REMOTE SENSOR ERROR"	Open remote temperature sensor circuit
07		Shorted remote temperature sensor circuit
08	"SUPPORT MODULES LOST"	All support modules with controlling temperature sensors are in error

## THERMOSTAT FEATURES

- Remote access and control over Wi-Fi.
- Indoor air quality control.
  - Humidification automatic or manual control.
  - Dehumidification.
  - Event-Based™ air cleaning.
  - Ventilation with temperature and humidity limits.
- Temperature control.
- Heat Blast® raises the room temperature 3°F to 5°F.
- Large touch screen with adjustable backlight – constant backlight option available.
- Message center provides feedback and instructions.
- 7 day programmability.
- Displays room temperature, room humidity, temperature setting, and outdoor temperature.
- Air filter, humidifier, dehumidifier, fresh air, and HVAC service reminders.
- Programmable fan control with fan circulation mode.
- Easy to use temperature control can override program schedule at any time.
- Progressive recovery ensures proper temperature at the start of a program event.
- Built in compressor protection prevents damage to your equipment.
- System test mode.

## SPECIFICATIONS

Environment	
Temperature	Operating: 32° to 120°F (0° to 48.9°C) Shipping: -30° to 150°F (-34.4° to 65.5°C)
Relative humidity	Operating: 5% to 90% R.H. (non-condensing)

Electrical	
Operating voltage	24VAC (18 – 30VAC)
Current	Maximum: 2.5A (total), 1.0A (single output) Maximum surge current: 5A

Thermal	
Outdoor & Remote temperature sensor	Maximum distance: 300 feet
Room temperature measurement	Display range: 32° to 99°F (0° to 40°C)
Outdoor temperature measurement	Display range: -40° to 130°F (-40° to 55°C)
Setpoint temperature range	Heat: 40° to 90°F (4° to 32°C) Cool: 50° to 99°F (10° to 37°C)
Setpoint humidity range	Humidification: 10% to 50% R.H. Dehumidification: 40% to 90% R.H.

**Aprilaire**<sup>®</sup>

P.O. Box 1467 • Madison, WI 53701-1467 • Phone: 800/334-6011 • Fax: 608/257-4357

**[www.aprilairepartners.com](http://www.aprilairepartners.com)**