

# TYPE A AIR ADJUSTED PILOT

CONTROLS -30 in. hg to 150 PSIG

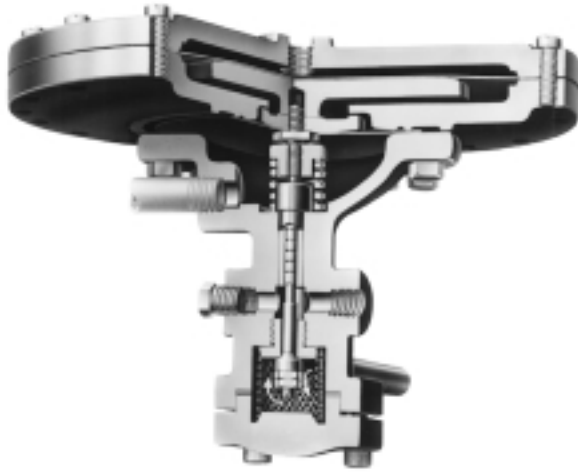

TYPE A73 AIR ADJUSTED PILOT

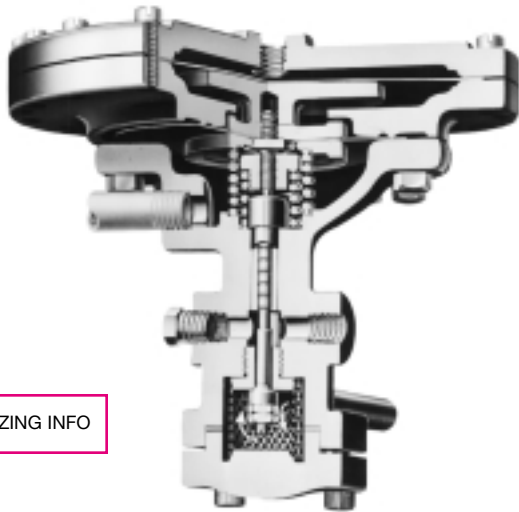

SIZING INFO

## TYPE A85 AIR ADJUSTED VACUUM PILOT

### APPLICATION DATA

- Pressure Regulating for Remote Locations
- Pneumatic Pressure Control
- Pneumatic Temperature Control
- Process Control where Controller is Far from Pilot

### RATINGS (Maximum Inlet Conditions)

Construction	Pressure PSIG (bar)	Temperature °F (°C)
Cast Iron	250 (17.2) @	450 (232)
Cast Steel	600 (41.4) @	750 (400)

### TYPICAL CONFIGURATIONS

- PRESSURE REDUCING .....TYPE **EA**
- PRESSURE REDUCING .....TYPE **E2A**
- PRESSURE REDUCING .....TYPE **E5A**
- PRESSURE REDUCING .....TYPE **E6A**
- WATER PRESSURE REDUCING.....TYPE **C34A**
- TEMPERATURE & PRESSURE .....TYPE **EAT61**

Canadian Registration # OC 0591.9C

- Air Loaded
- Remote Control
- Spring Operated
- Normally Closed
- Packless Construction
- Economic Use of Air
- Ease of Adjustment
- Accurate to  $\pm 1$  psi
- Delivery to Loading Air Pressure Ratios from 5/8 to 1 up to 6-2/3 to 1 psi
- Fluid, Gas & Vapor Applications
- Accurate Regulation Unaffected by Service Conditions
- Easy In-line Maintenance

### OPTIONS

- Integral Mount
- Air Filter Regulator/Gauges

### MODELS\*

- **TYPE A** for pressure control at low pressures. Delivery to loading pressure is 1 to 1 psi.
- **TYPE A35** for pressure control at very low delivery pressures as in some heating system control. Delivery to loading pressure is 1/2 to 1 psi.
- **TYPE A43 & A54** for pressure control at medium to high pressures. Delivery to loading pressure is 2% to 1 psi.
- **TYPE A53** for pressure control at medium pressures. Delivery to loading pressure is 4 to 1 psi.
- **TYPE A70 & A73** for pressure control at high delivery pressures when available loading air is at low pressure. Delivery to loading pressures are 15 and 6% (respectively) to 1 psi.
- **TYPE A82** Vacuum for pressure control of very low pressure or systems varying between very low pressure and light vacuum. Delivery to loading pressure is 1 to 1 psi.
- **TYPE A83** Vacuum for temperature control. Delivery to loading pressure is 1 to 1 psi.
- **TYPE A84** Vacuum for temperature control at lower delivery pressure features more gradual response. Delivery to loading pressure is 2% to 1 psi.
- **TYPE A85** Vacuum for temperature, pressure and vacuum control. Delivery to loading pressure is 3% to 1 psi.
- **TYPE A86** for pressure control at low pressures. Delivery to loading pressure is 1 to 1 1/6 psi.
- **TYPE A87** Vacuum for temperature, pressure and vacuum control. Delivery to loading pressure is 8% to 1 psi.

\*Ranges are approximate.

# TYPE A AIR ADJUSTED PILOT SPECIFICATION

The Pilot shall be separate from the main valve and connected to it with a male union. The Pilot shall be normally closed design with packless construction. A strainer screen shall be built into the Pilot inlet. The Pilot shall be interchangeable on all sizes of main valves.

## MATERIALS OF CONSTRUCTION

Body, Cast Iron .....	ASTM A126 CI B
Body, Cast Bronze .....	ASTM B61 UNS C92200
Body, Cast Steel .....	ASTM A216 GR. WCB
Stem .....	303 St. Stl. ASTM A582 COND A
Disc .....	440 St. St. ASTM A276-75 COND A
Seat .....	420 St. Stl ASTM A276 COND A
Gasket .....	Non-Asbestos
Diaphragm .....	301 St. Stl. MIL-5-5059C
Spring .....	Inconel

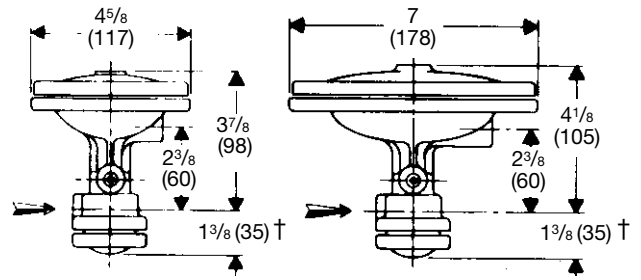

**Type A or A83**  
6 lbs (2.7 kg)

**Type A82**  
11 lbs (5 kg)

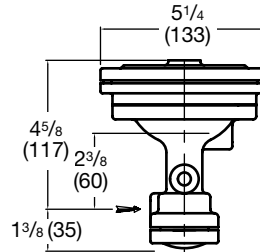

**Type A43**  
11 lbs (5 kg)

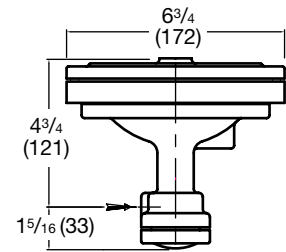

**Type A54**  
19 lbs (8.6 kg)

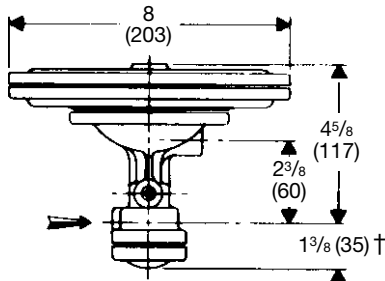

**Type A73 or A70**  
15 lbs (6.8 kg)

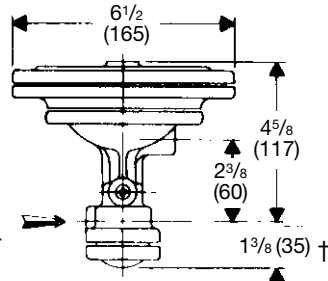

**Type A53 or A85**  
12 lbs (5.5 kg)

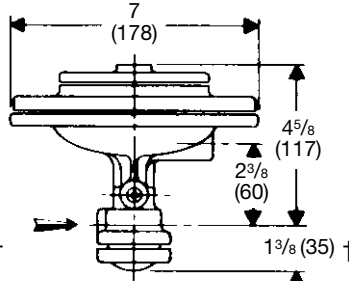

**Type A35**  
14 lbs (6.4 kg)

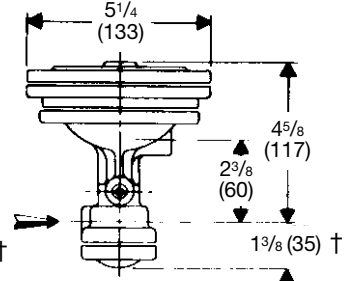

**Type A84 or A86**  
11 lbs (5 kg)

†For Integral Mount Pilot, this dimension is 5/8" (16).

## PILOTS FOR POSITIVE PRESSURE

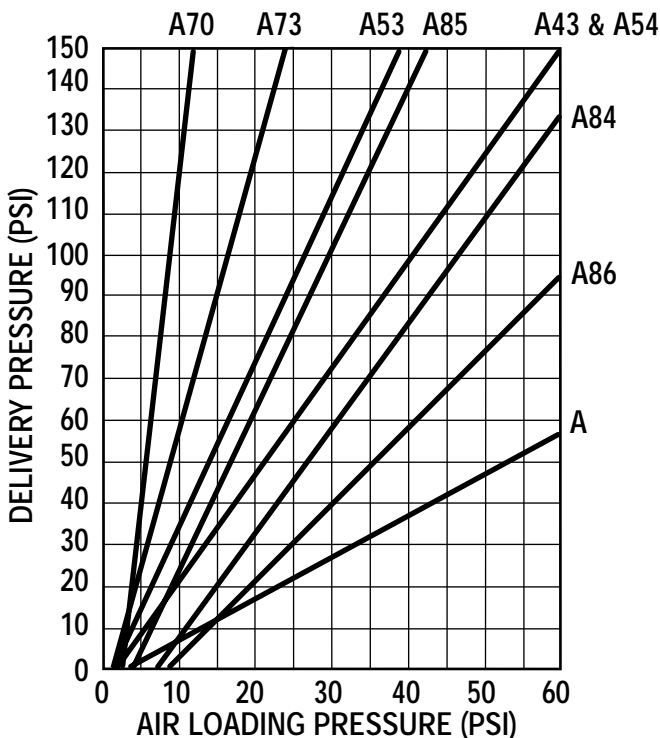

## PILOTS FOR VACUUM PRESSURE

